

Installation

The open-style design of the SMC Dialog Plus controller requires that it be installed in an enclosure. **The internal temperature of the enclosure must be kept within 0°C to 5 °C (32°F to 12 °F).**

The controller is convection cooled. It is important to mount the controller in a position that allows air to flow vertically through the power structure. Allow for a minimum of six inches (15 cm) of free space around all sides of the controller.

Wiring

Power Wiring

Refer to the product nameplate for power lug termination information including:

- Lug wire capacity
- Tightening torque requirements
- Lug kit catalog numbers (97-1000A)

Control Wiring

Refer to the product nameplate for control terminal wire capacity and tightening torque requirements. Each control terminal will accept maximum of two wires.

The SMC Dialog Plus controller accepts control power input of either 100-240 V AC, (+ 10/-15%) single-phase, 50/60Hz or 24V AC/DC. Refer to the product nameplate prior to applying control power. Connect control power to the controller at terminals 11 and 12. The control power requirement for the control module is 40 VA. For controllers rated 97-1000A, control power is also required for the heatsink fans as defined in Table C. Depending on the specific application, additional control circuit transformer VA capacity may be required.

Table A
Heatsink Fan Power Requirements

SMC Rating	Heatsink Fan V
97-360A	45
500A	145
650-1000A	320

Control Terminals

Figure 1
SMC Dialog Plus Controller Control Terminals

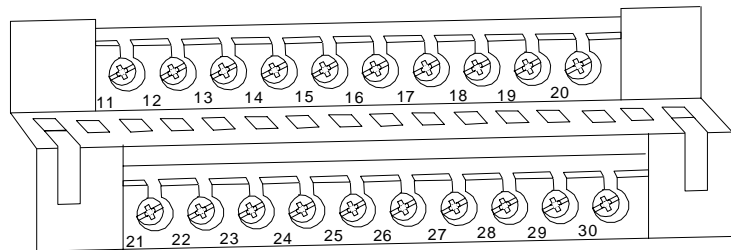
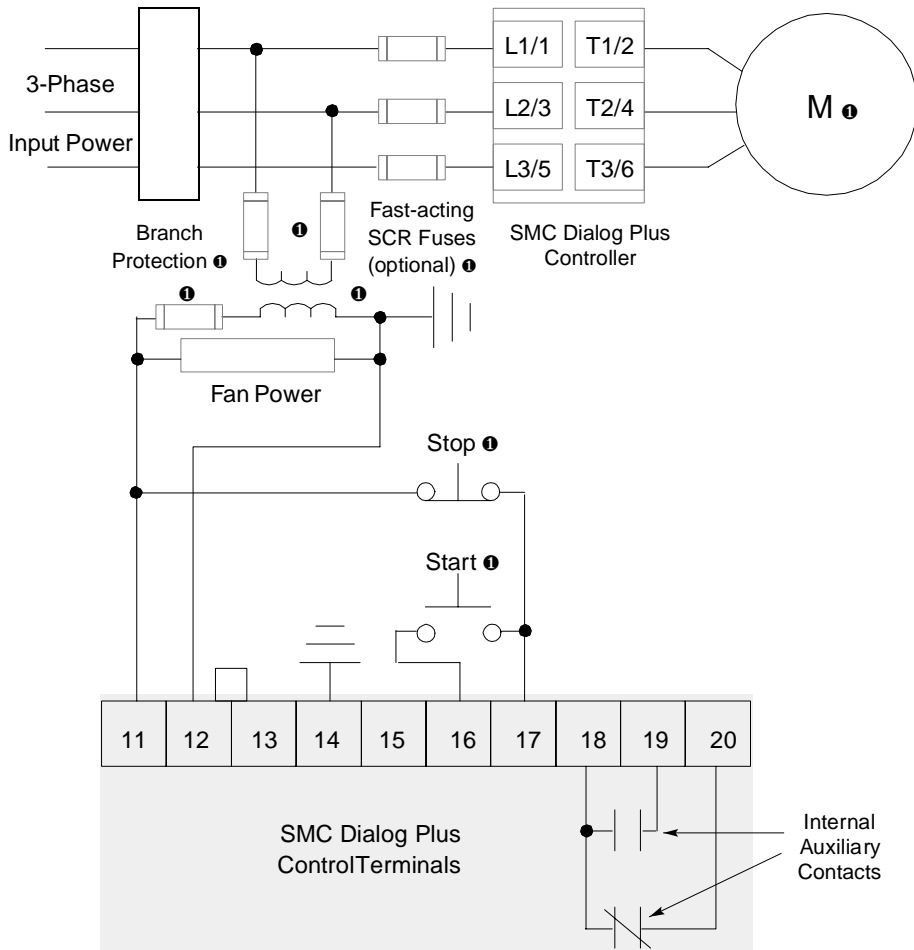

Table B
Control Terminal Designation

Terminal Number	Description
11	Control Power Input
12	Control Power Common
13	Controller Enable Input ❶
14	Logic Ground
15	Dual Ramp/Option Input ❶
16	Start Input ❶
17	Stop Input ❶
18	Auxiliary Relay Common
19	N.O. Auxiliary Contact #1
20	N.C. Auxiliary Contact #2
21	Not Used
22	Not Used
23	Not Used
24	Not Used
25	Converter Module Fanning Strip Connection ❶
26	Converter Module Fanning Strip Connection ❶
27	Converter Module Fanning Strip Connection ❶
28	Converter Module Fanning Strip Connection ❶
29	Auxiliary Contact #3
30	Auxiliary Contact #3

❶ Do not connect any additional loads to these terminals. These "parasitic" loads may cause problems with operation, which may result in false starting and stopping.

Figure 2
Typical Wiring Diagram



① Customer supplied.

Figure 3
Heatsink Fan Wiring

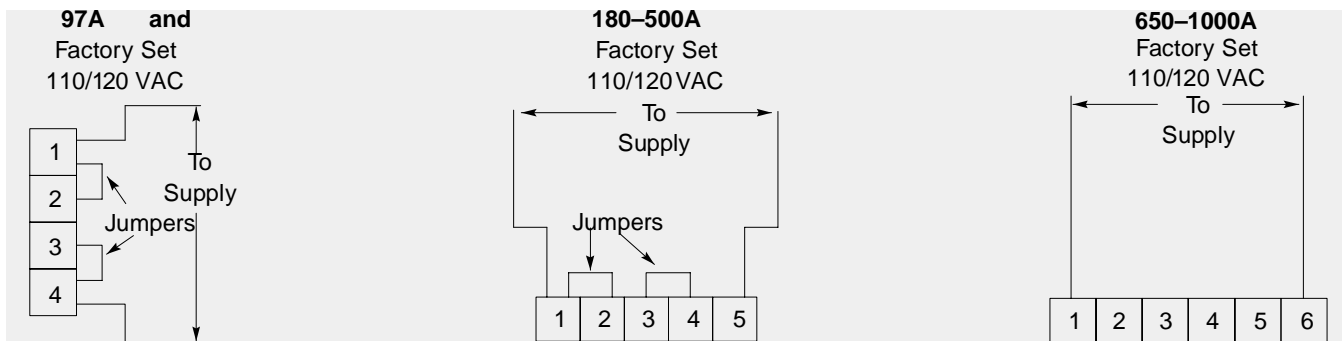

Refer to Chapter 3 of the *SMC Dialog Plus Controller User Manual* (Publication 150-5.3) for optional 220/240V AC fan power connections and other sample wiring diagrams. Chapter 7 of Publication 150-5.3 also provides typical wiring diagrams for the control options (for example, Pump Control).