



Miniature Flat Pack



Specifications

Load Current	50mA max. @ 12V DC/100mA max. @ 24V DC
Current Consumption	10mA max.
Operating Voltage	10-30V DC
Voltage Drop	≤1V
Repeatability	≤5%
Hysteresis	10% typical
Reverse Polarity Protection	Incorporated
Approvals	CE marked for all applicable directives
Enclosure	NEMA 1, 2, 3, 4X, 6, 12, 13, IP67 (IEC 529)
Connections	2m Cable
LED	Red: Output Energized
Operating Temperature	-25°C to +70°C (-13°F to +158°F)
Shock	Approx. 50g, 3 times
Vibration	10 to 55Hz, @ 1.5mm

Features

- 5mm sensing distance
- 2m cable
- PNP/NO output
- Plastic housing
- CE marked for all applicable directives

Dimensions—mm (inches)

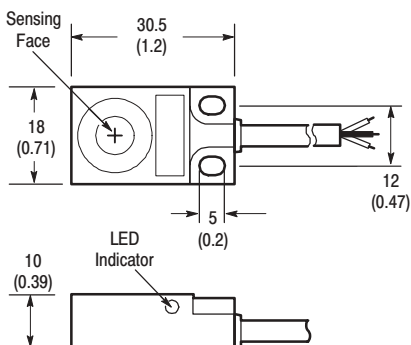

Wiring Diagrams

Pico QD Style
Normally Open

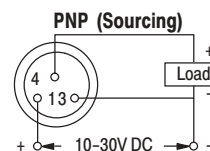

Selection Guide

Sensor Size	Nominal Sensing Distance—mm (in)	Output Configuration		Catalog Number
				Pico QD Style
31 x 18 x 10	5mm (0.20)	N.O.	PNP	871FM-D5NP10-E2

