

## Installation

### Chapter Objectives

Chapter 2 provides information to help you:

- set the module configuration switches
- mount the remote I/O module
- connect the remote I/O cable
- connect the termination resistor
- connect the SCANport link
- connect the power supply

Read this chapter completely before you attempt to install or configure your remote I/O communications module. Double check all connections and option selections before you apply power.

**Important:** Switch selections take effect only on power-up. If you change selections after power is applied, cycle the power to use the new settings.

### Setting the Module Configuration Switches

This publication describes switches as being either on or off. If the switch assembly has the word OPEN printed on it, the word OPEN corresponds to OFF (O).

When you change the adapter board configurations, keep in mind the addressing conventions of the type of processor that you are using. In all cases, each remote I/O device must have a unique address that the processor can recognize.

**Important:** This adapter is not compatible with complementary I/O configurations because the adapter uses both output and input image words for proper drive control.



**ATTENTION:** When you make changes to the switch settings, use a blunt, pointed instrument such as a ball point pen. Do not use a pencil because the lead (graphite) of the pencil may damage the switch assembly.

**ATTENTION:** Failure to check connections and switch settings for compatibility with your application when configuring the communications module, could result in personal injury and/or equipment damage due to unintended or undesirable operation of the drive or process equipment.

---

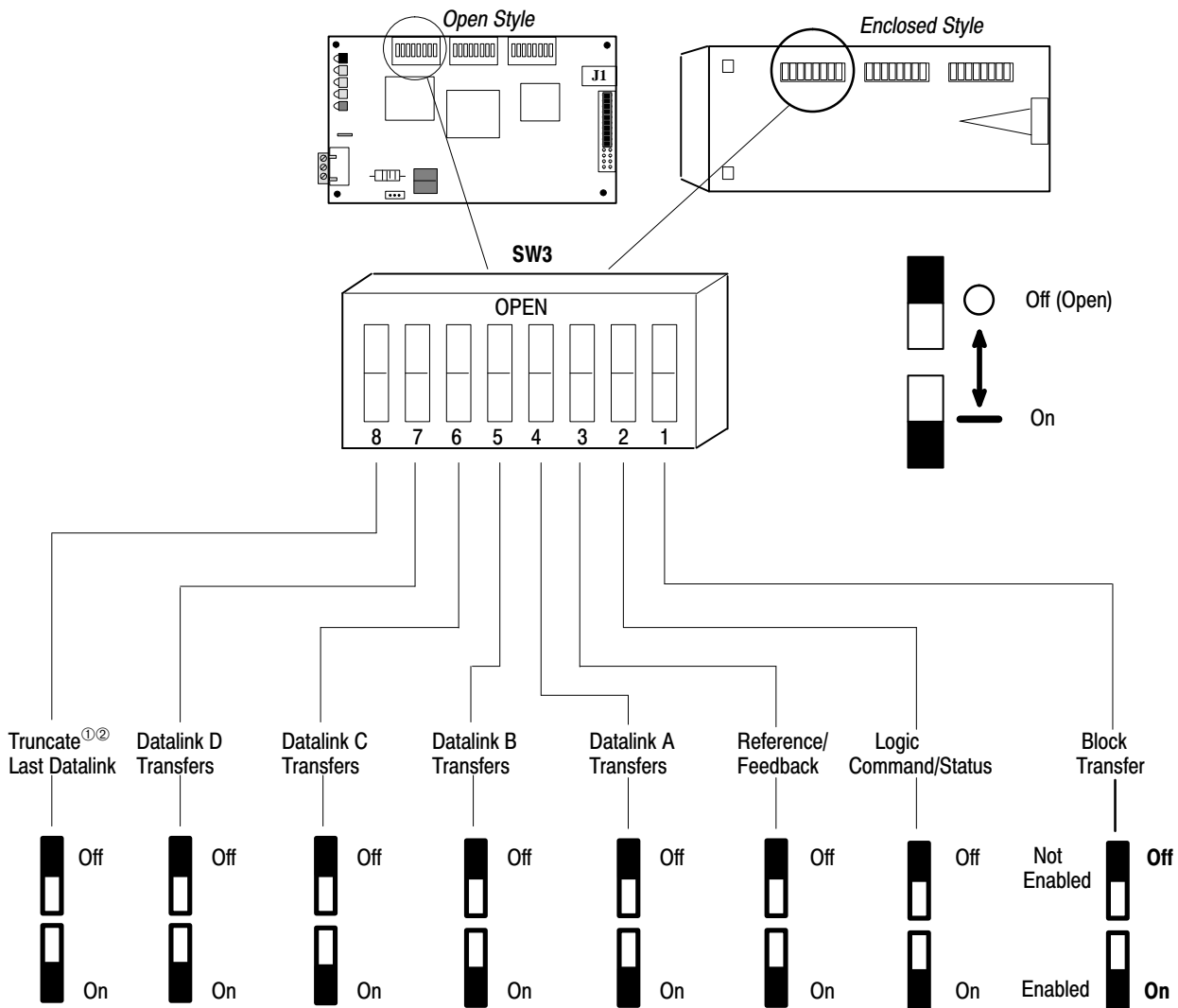
### Switch SW3

Set switch SW3 first. The settings on this switch determine how the SCANport device uses the data contained in the programmable controller I/O image table. SW3 also establishes the minimum rack size that this communications module requires.

▶ The switches are labeled in the same orientation as they appear on the board.

Table 2.A, SW3 Image Table Map, and Figure 2.2, SW3 Flowchart, are included to help you set the DIP switches properly. It may also be helpful to color in the final switch settings in Figure 2.1 as a visual record of your SW3 settings. Chapter 3 contains several examples of how to fill in the worksheet and set these DIP switches.

**Figure 2.1**  
**Configuration Switch SW3 Settings**



① IMPORTANT: Only available on communications modules with version 1.02 or later firmware.

② All datalinks are two words, the truncate function will delete the last datalink word. (If "Datalink B" is the last used, "Data in B2" and "Data Out B2" will be truncated.)

**Table 2.A  
SW3 Image Table Map**

RESERVED FOR:		Minimum Required Rack Size <sup>①</sup>	Start At Group
Output Image	Input Image		
		1/4 Rack	0, 2, 4, or 6
		Half Rack	0, 2, or 4
		3/4 Rack	0 or 2
		Full Rack	0 only

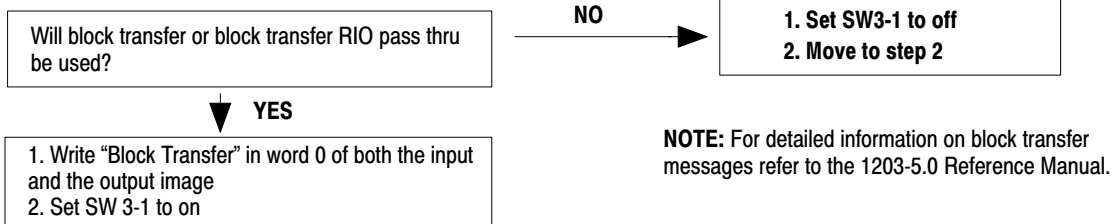
<sup>①</sup> Use this to select settings for switch SW2, switches 1 and 2

How to use Table 2.A:

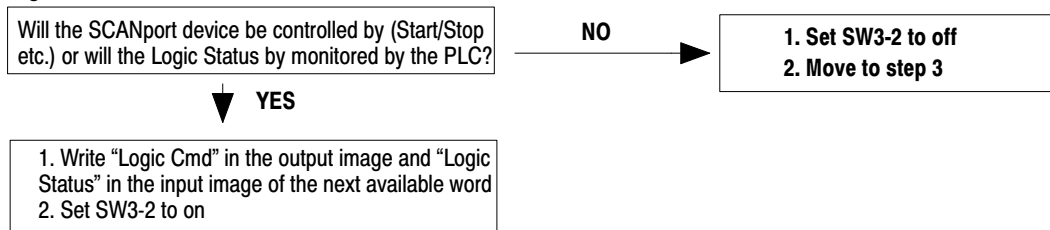
1. Use Figure 2.2 to set DIP switch SW3 and fill out Table 2.A.
2. Use minimum rack size shown in Table 2.A to set DIP switch SW2-1 and SW2-2.

**Figure 2.2  
SW3 Flowchart**

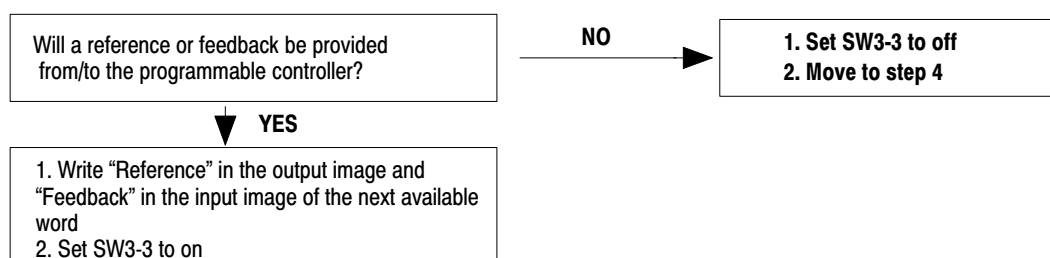
**Step 1. Block Transfer**



**Step 2. Logic Command**

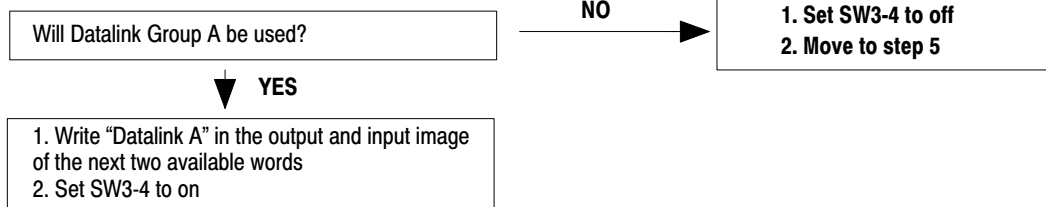


**Step 3. Reference/Feedback**

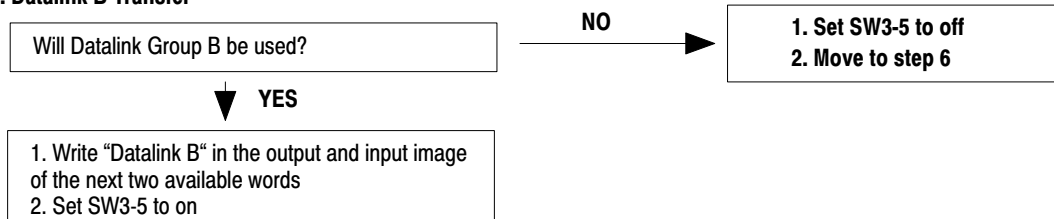


**Figure 2.2**  
**SW3 Flowchart continued**

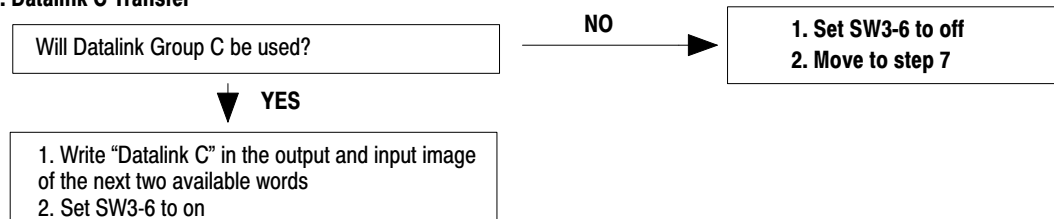
**Step 4. Datalink A Transfer**



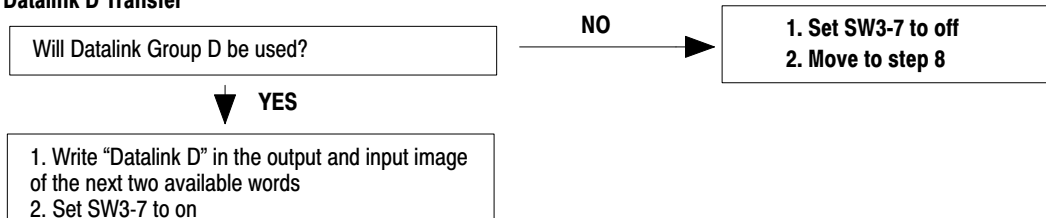
**Step 5. Datalink B Transfer**



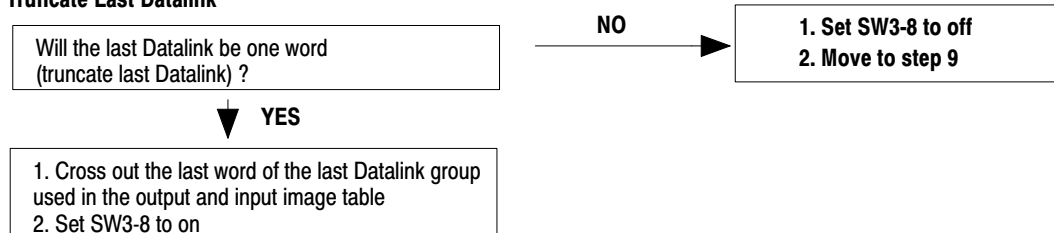
**Step 6. Datalink C Transfer**



**Step 7. Datalink D Transfer**



**Step 8. Truncate Last Datalink**



**Step 9. Calculate minimum rack size**

Refer to Table 2.A on page page 2-3.

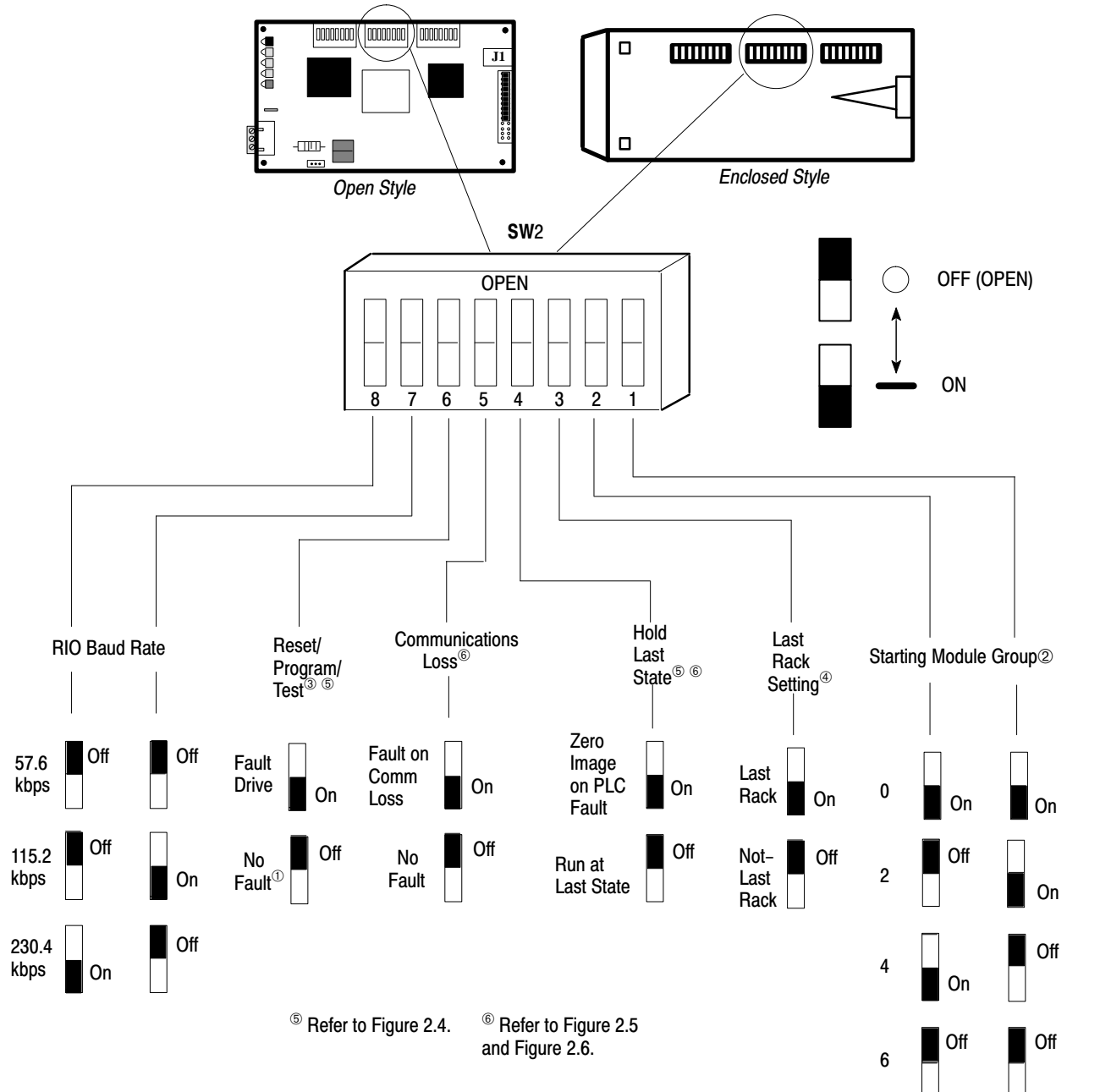
1. Record the minimum rack size in Table 2.A on page 2-3.
2. Use the minimum rack size to set Dip switches SW2-1 and SW2-2.

### Switch SW2

Switch SW2 determines Rack Size, Last State, Rack Fault, and Bit Rate Selections as shown in Figure 2.3.

▶ The switches are labeled in the same orientation as they appear on the board.

**Figure 2.3**  
Configuration Switch SW2 Settings



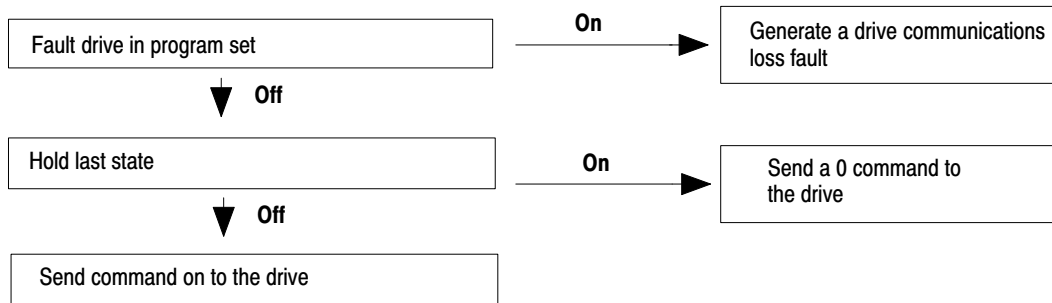
① If this switch is set to No Fault, the setting of the Hold Last State switch determines the data sent to the SCANport device when the PLC is in Reset/Program/Test.

② The setting of this switch is determined by the amount of discrete I/O that will be passed between the PLC and the drive. Refer to Table 2.A for more information.

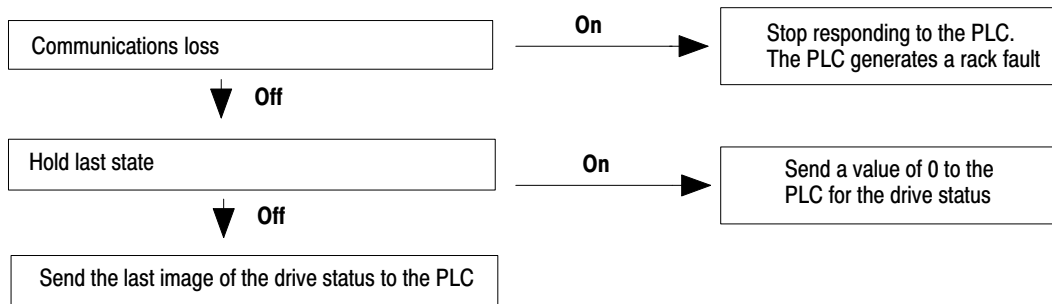
③ This switch is active on Firmware Version 2.xx modules only. It is not used by modules containing Firmware Version 1.xx.

④ Set this switch on the last module used for a given rack address. It does not electrically terminate the RIO link.

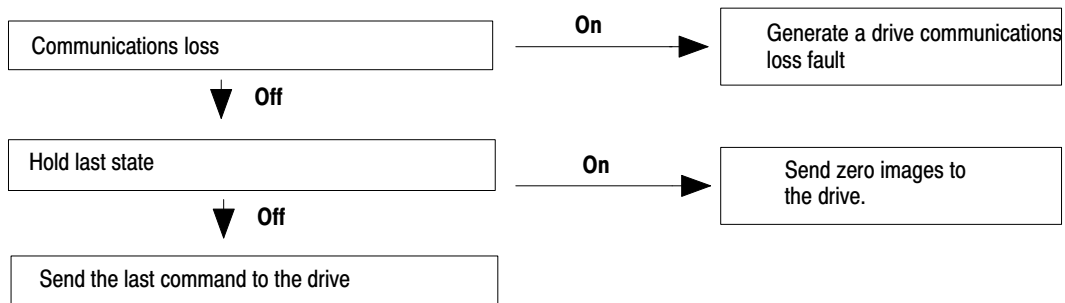
**Figure 2.4  
PLC Switched to Program**



**Figure 2.5  
SCANport Cable Unplugged**



**Figure 2.6  
RIO Cable Disconnected**

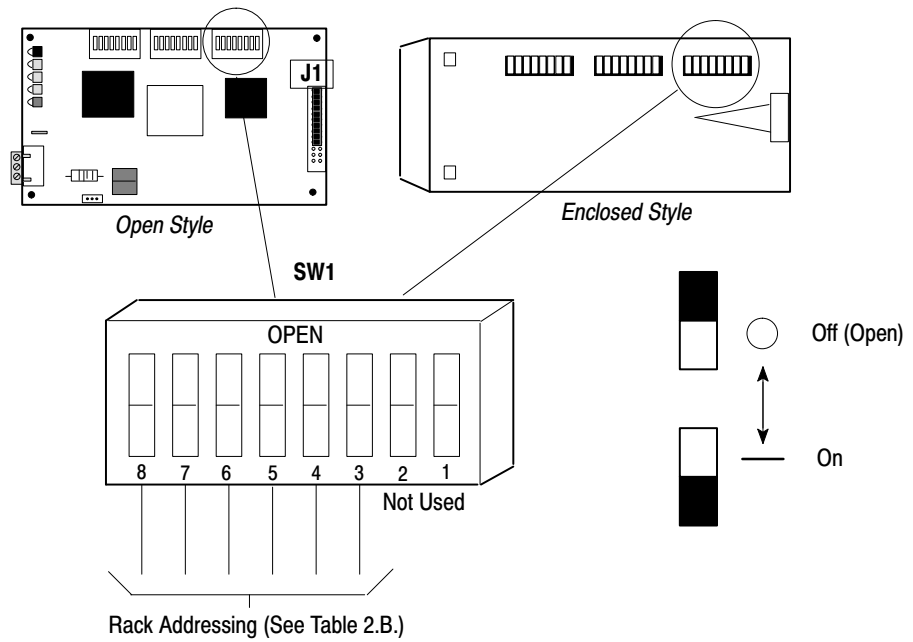


### Switch SW1

Switch SW1 controls starting quarter and rack address options as shown in Figure 2-7.

- ▶ **Note:** When using a PLC-2 family processor, you need to offset the value of the rack number by one. The PLC-2 cannot have a remote I/O rack numbered zero. Therefore, add a value of one to the Rack No value in Table 2.B when writing your PLC code.

**Figure 2.7**  
**Configuration Switch SW1 Settings**



**Table 2.B**  
**Switch SW1 Settings**  
**SW1-8 through SW1-1 DIP Switch Definitions, Rack Address**

Rack No.	SW1-8	SW1-7	SW1-6	SW1-5	SW1-4	SW1-3	SW1-2	SW1-1
00	On	On	On	On	On	On		not used
01	Off	On	On	On	On	On		not used
02	On	Off	On	On	On	On		not used
03	Off	Off	On	On	On	On		not used
04	On	On	Off	On	On	On		not used
05	Off	On	Off	On	On	On		not used
06	On	Off	Off	On	On	On		not used
07	Off	Off	Off	On	On	On		not used
10	On	On	On	Off	On	On		not used
11	Off	On	On	Off	On	On		not used
12	On	Off	On	Off	On	On		not used
13	Off	Off	On	Off	On	On		not used
14	On	On	Off	Off	On	On		not used
15	Off	On	Off	Off	On	On		not used
16	On	Off	Off	Off	On	On		not used
17	Off	Off	Off	Off	On	On		not used
20	On	On	On	On	Off	On		not used
21	Off	On	On	On	Off	On		not used
22	On	Off	On	On	Off	On		not used
23	Off	Off	On	On	Off	On		not used
24	On	On	Off	On	Off	On		not used
25	Off	On	Off	On	Off	On		not used
26	On	Off	Off	On	Off	On		not used
27	Off	Off	Off	On	Off	On		not used
30	On	On	On	Off	Off	On		not used
31	Off	On	On	Off	Off	On		not used
32	On	Off	On	Off	Off	On		not used
33	Off	Off	On	Off	Off	On		not used
34	On	On	Off	Off	Off	On		not used
35	Off	On	Off	Off	Off	On		not used
36	On	Off	Off	Off	Off	On		not used
37	Off	Off	Off	Off	Off	On		not used

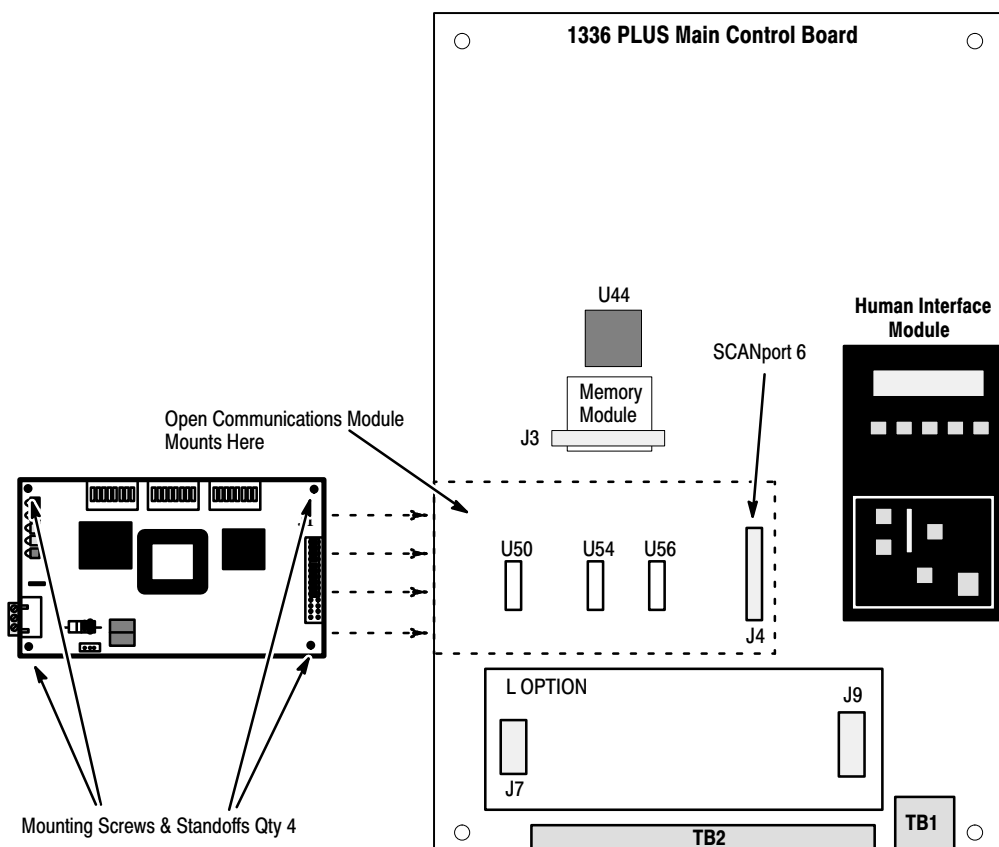
## Mounting the Remote I/O Module

The remote I/O communications module can be provided in three mounting configurations:

- Open Style board factory installed in a drive (not available for all drives)
- Open Style board as a separate kit
- Enclosed style for panel mount or DIN rail mount

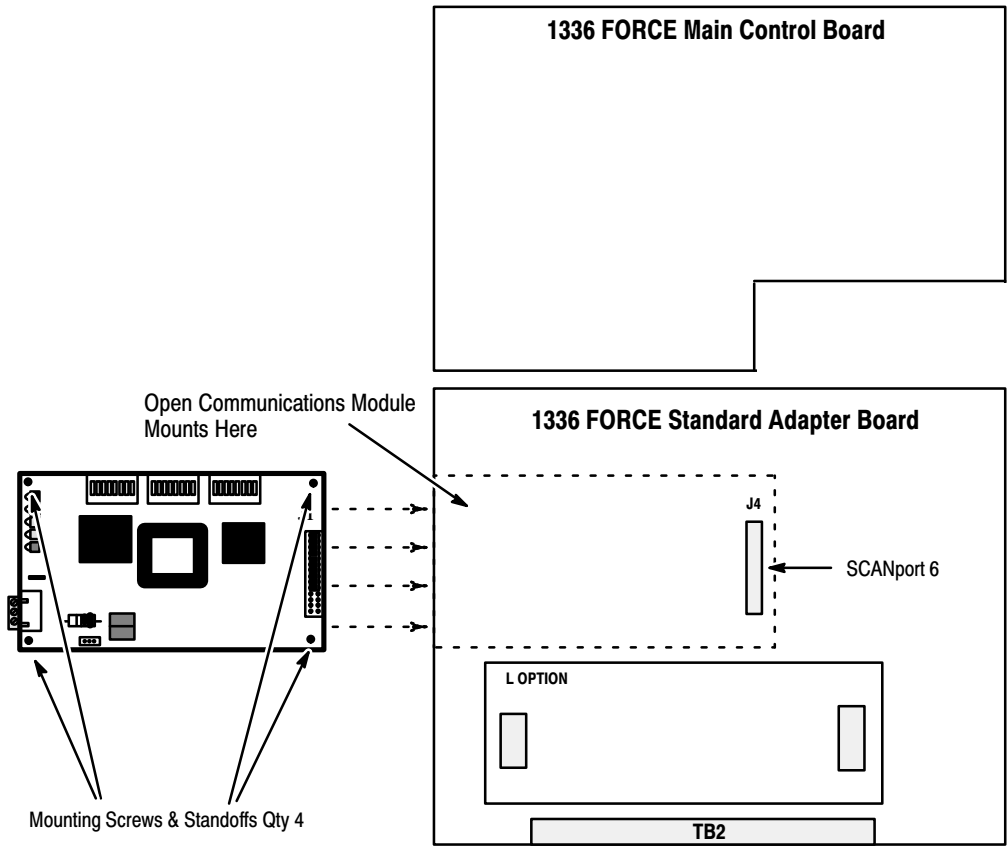
This section provides mounting information for the Enclosed style and the Open style kit.

**Figure 2.8**  
**Open Style Communications Module Mounting Location (1336 Plus 7.5-500HP)**



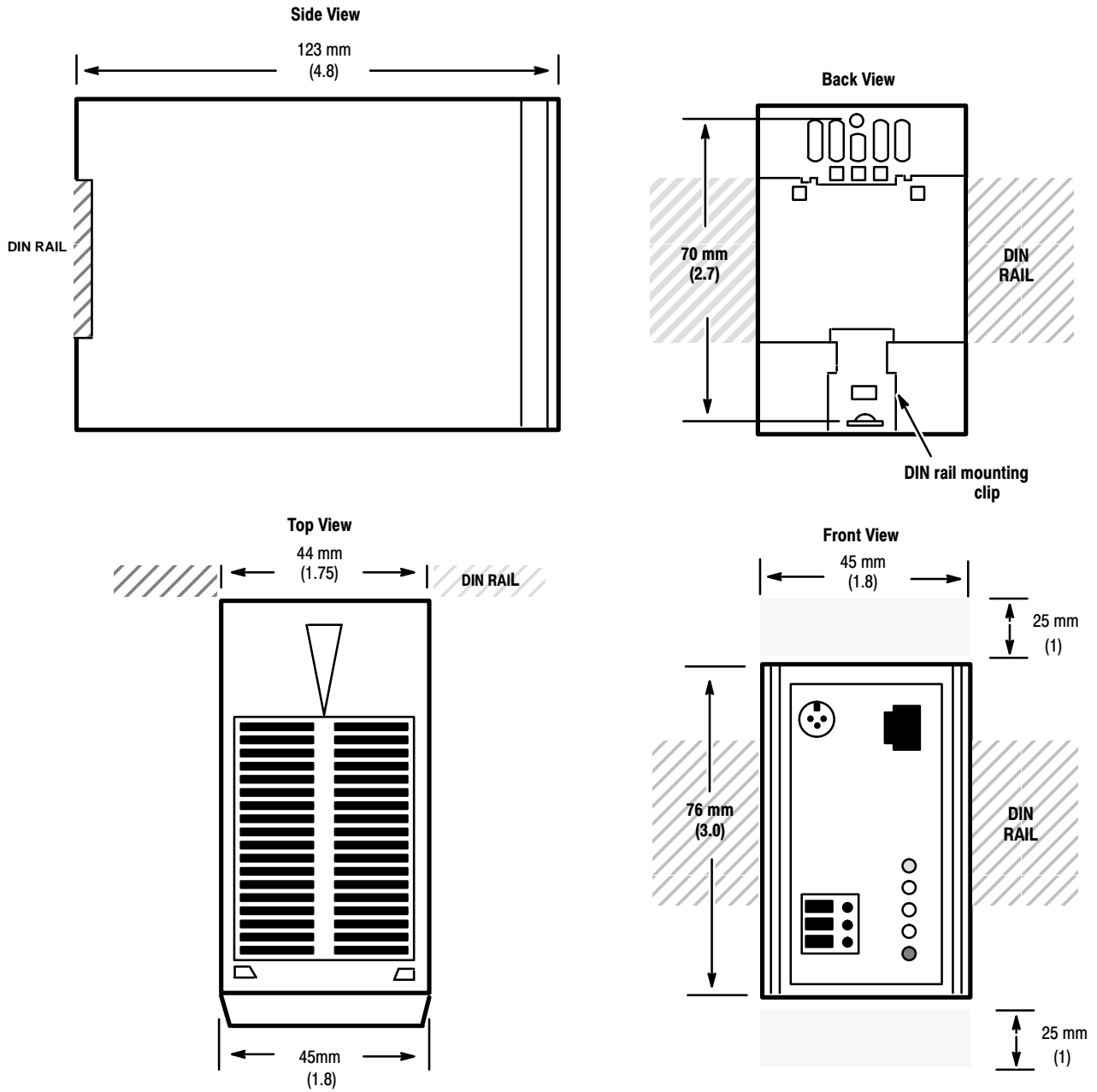
Install the board with the component side facing you.

**Figure 2.9**  
**Open Style Communications Module Mounting Location (1336**  
**FORCE Drive)**



Install the board with the component side facing you.

**Figure 2.10**  
**Enclosed Style Communications Module Dimensions**



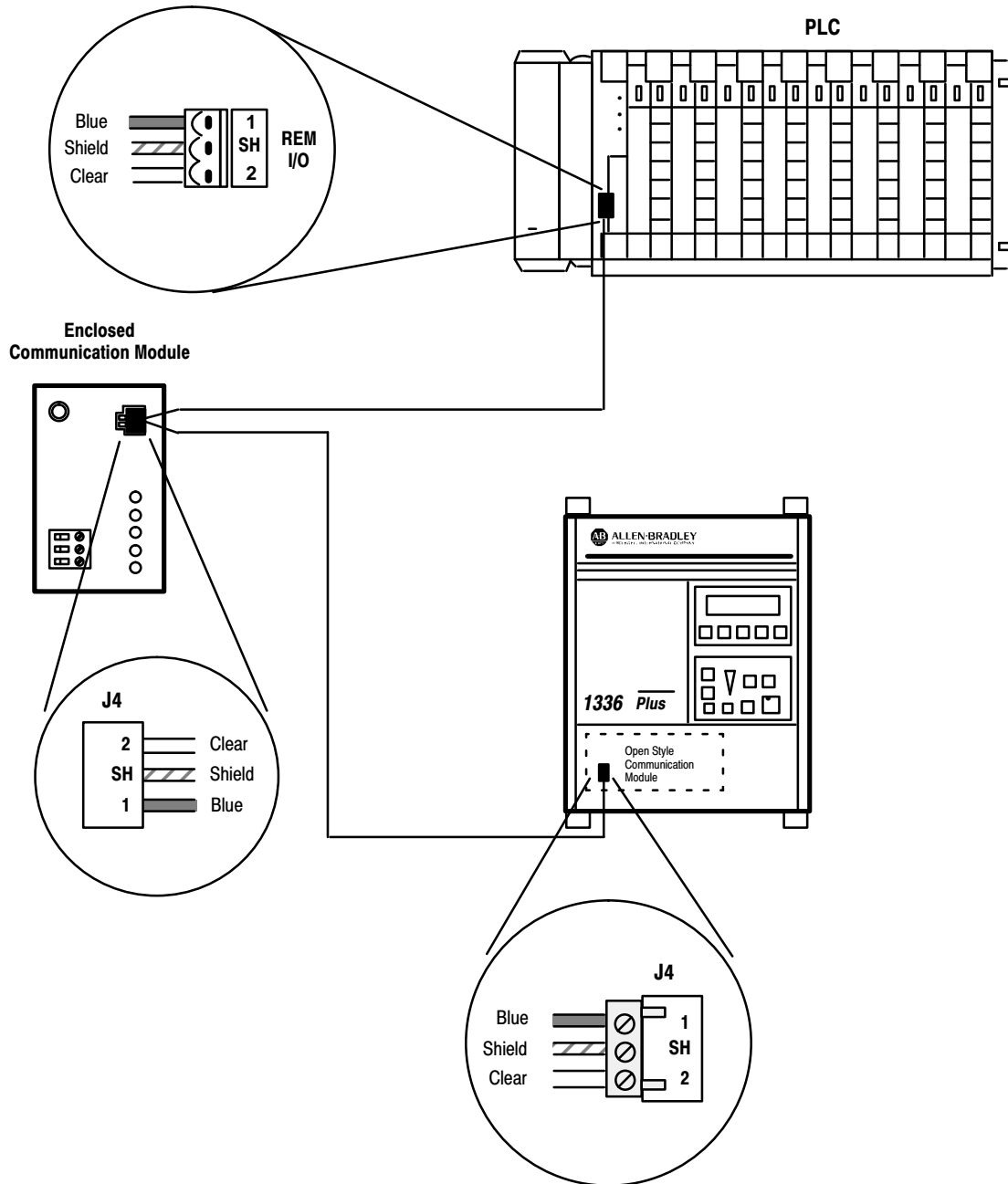
**Note:** The enclosure requires clearance at the top and bottom for proper cooling. Additional space will be required if access to DIP switches is desired without having to remove the device.

All dimensions in millimeters and (inches)

## Connecting the Remote I/O Cable

You must connect remote I/O communications module cables as shown in the example in Figure 2.11. Refer to Table 2.C for cable guidelines.

**Figure 2.11**  
Remote I/O Module Interconnections



Twinaxial cable used for remote I/O (RIO) and Data Highway+ (DH+™) communications represents a communications transmission line in which certain characteristics exist. The following are some general guidelines that must be adhered to in order to obtain the best results.

**Cable Type** – Only 1770-CD Belden #9463 is approved for RIO and DH+ installations. All other cable types or manufacturers, no matter how similar, are untested. Using other cable types is strictly at your own risk.

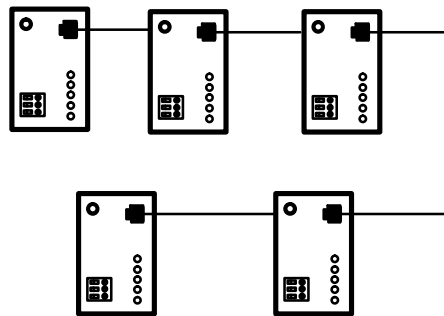
**Important:** The transmission rate determines the maximum cable length.

**Table 2.C**  
Twinaxial Cable Guidelines

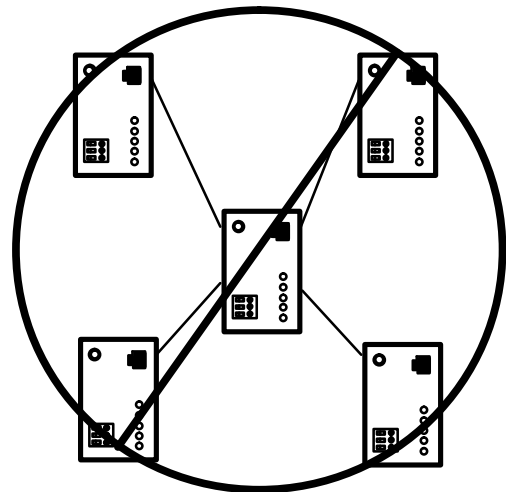
Remote I/O link communications rate	Cable length cannot exceed:
57.6 kbps	3,048 m (10,000 ft)
115.2 kbps	1,524 m (5,000 ft)
230.4 kbps	762 m (2,500 ft)

**Connections** – Connect all three conductors, blue, clear, and shield, at each wiring point. No additional ground connections should be made to the shield.

**Important:** DO NOT use star type connections. Only two cables may be connected at any wiring point on a series connection application.



OK



These are general rules and certain deviations may be warranted because diverse installation and environmental concerns could change the requirements.

## Connecting the Termination Resistor

You must terminate both ends of a remote I/O link to ensure proper operation. This termination is required only at the ends of the physical cable. Each remote I/O network should have exactly two termination resistors installed. Use Table 2.D and Figure 2.12 and Figure 2.13 to determine the proper termination for your particular link. Termination resistor R3 is located on the board, and the J2 jumper selects this resistor.

**Table 2.D**  
**Termination Resistor Requirements**

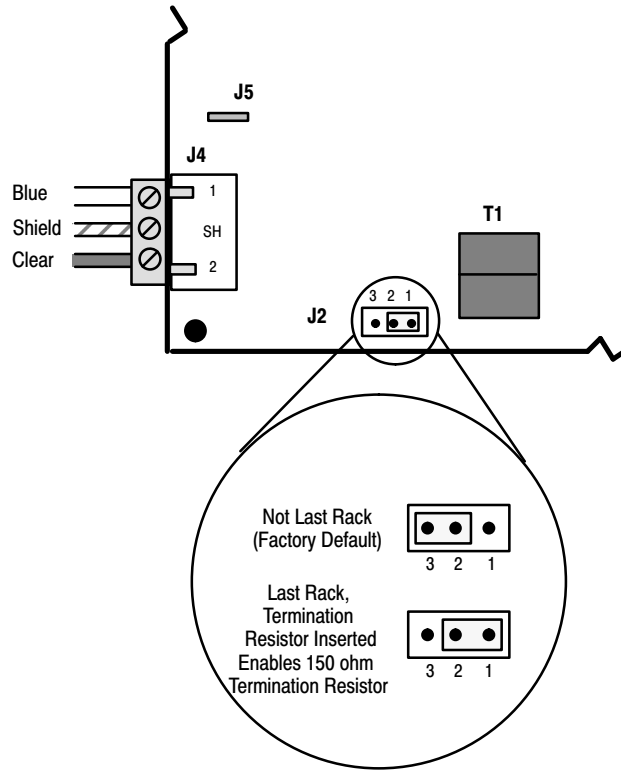
If this device is an end device of a remote I/O link:	Terminate the link by:
Programmable controller	Refer to the manual for your model processor.
Open style, single point remote I/O adapter	Set jumper J2 in position 1-2 for termination and 2-3 for no termination as shown in Figure 2.12. The jumper enables a 150 ohm resistor as the terminator resistor.
Enclosed style single point remote I/O adapter	<p>Connect a terminator resistor between the remote I/O terminals labeled 1 and 2 as shown in Figure 2.13. Use either a 150 Ohm or an 82 Ohm terminator.</p> <ul style="list-style-type: none"> <li>• You must use an 82 Ohm resistor if the remote I/O link is operating at 230.4 kbps (terminator must be connected at both the scanner and the adapter).</li> <li>• You should use an 82 Ohm resistor if the remote I/O link is operating at 57.6 kbps or 115.2 kbps unless one of the devices on the link is listed in Table 2.E. If you are using a device listed in Table 2.E, then you must use a 150 Ohm terminator.</li> </ul>

**Important:** The following products (Table 2.E) cannot be on a link using 82-Ohm termination resistors.

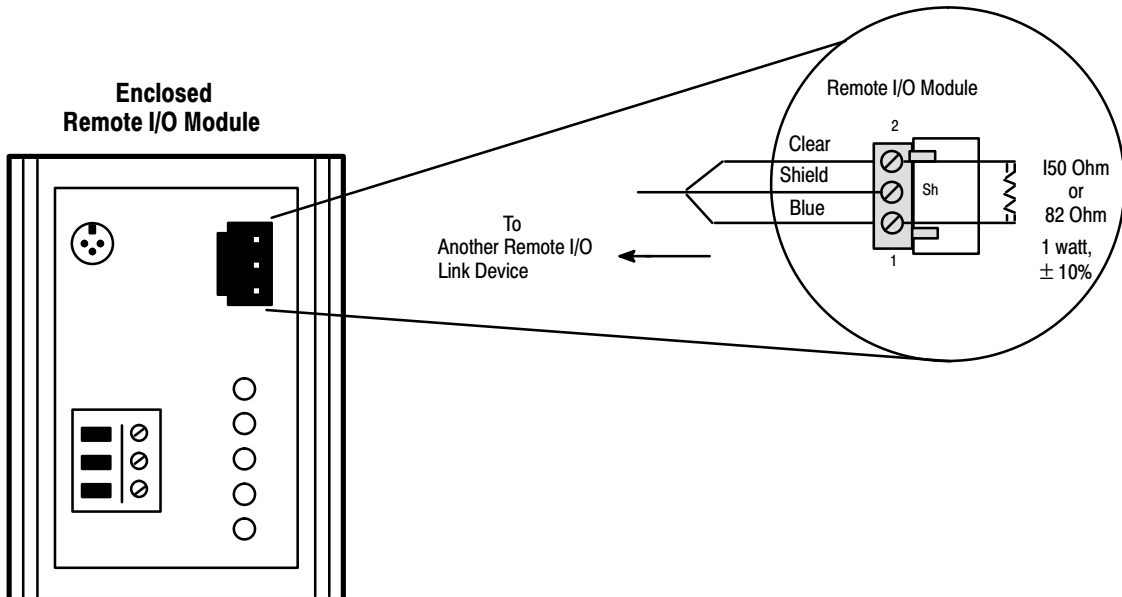
**Table 2.E**  
**Unsupported Remote I/O Link Devices**

Device Type	Catalog Number	Series
Scanners	1771-SN	All
	1772-SD, -SD2	
	1775-SR	
	1775-S4A, -S4B	
	6008-SQH1, -SQH2	
Adapters	1771-AS	All
	1772-ASB	A
	1771-DCM	All
Miscellaneous	1771-AF	All

**Figure 2.12**  
Terminating a Remote I/O Link Using the Module Mounted Resistor



**Figure 2.13**  
Terminating a Remote I/O Link Using an External Resistor



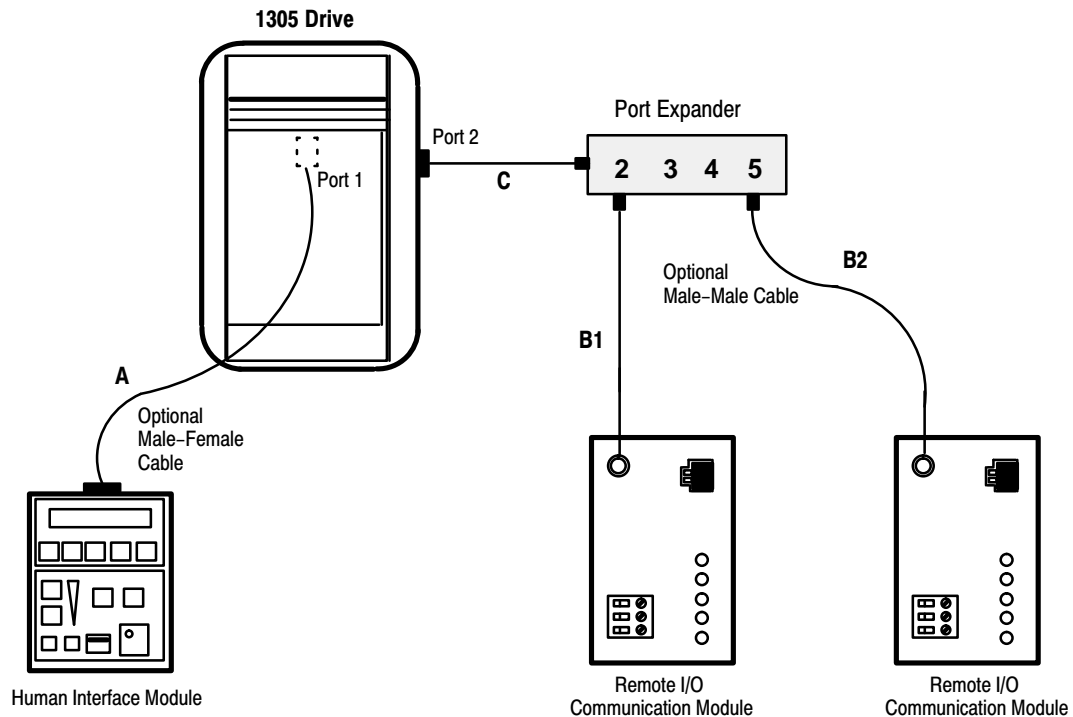
## Connecting the SCANport Link

SCANport cables are available in either Male-to-Male or Male-to-Female configuration. You can connect cables of up to 10 meters (33 feet) from the master to the SCANport device (A in Figure 2.14). If you use a port expander as shown in Figure 2.14, subtract the cable length from the master to the port expander from the cable length used to connect the device to the expander ( $B1 + C =$  maximum 10 meters).

### 1305 Drive

An Allen-Bradley SCANport link cable is used to make the connection between the communications module and the drive (Figure 2.14).

**Figure 2.14**  
SCANport connection on Remote I/O



**Important:** The maximum cable distance between any two master devices cannot exceed 10 meters (33 feet) of cable. For example,  $B1 + C =$  maximum of 10 meters or  $B1 + B2 =$  maximum of 10 meters.

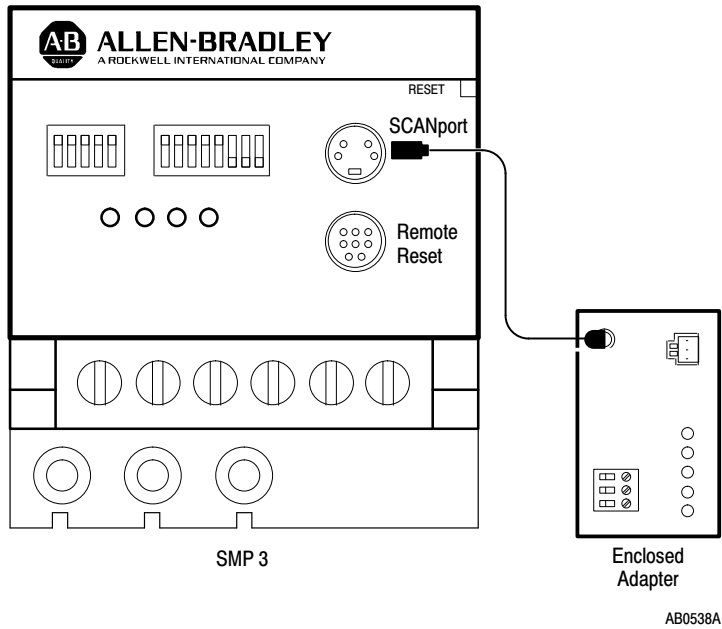
### 1336 PLUS (7.5 – 500HP) and 1336 FORCE

Refer to the product manual for connection information. On larger horsepower 1336 PLUS and 1336 FORCE drives with an open remote I/O module mounted in the drive, you do not need a separate SCANport cable connection.

### SMP 3

An Allen-Bradley SCANport cable is used to connect the communications adapter and an SMP 3. See the cable requirements on page 2-16 for details on cable length.

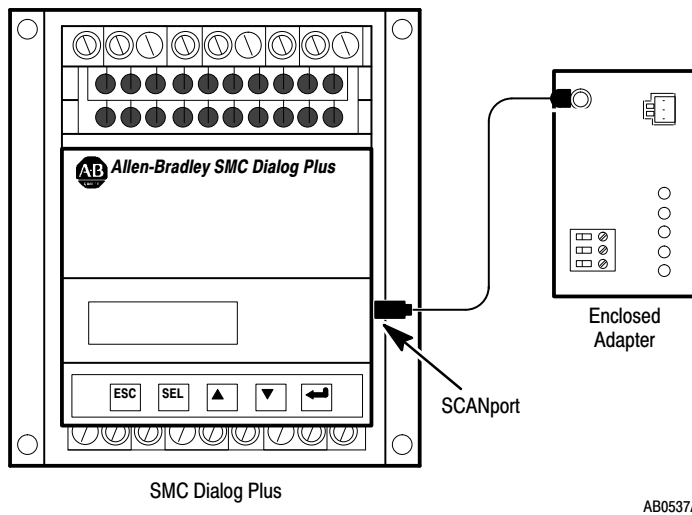
**Figure 2.15**  
SCANport connection on Remote I/O



### SMC Dialog Plus

An Allen-Bradley Bulletin 1202 SCANport cable is required to connect the communications adapter and the SMC Dialog Plus controller.

**Figure 2.16**  
SCANport connection on Remote I/O



## Connecting the Power Supply

The Enclosed remote I/O is powered from a separate 24V dc or 115V ac power supply (Figure 2.17). With the open style remote I/O board mounted in the drive, no separate power supply connections are required.

**Figure 2.17**  
**Typical Power Supply Connection**

