



# ALLEN-BRADLEY BULLETIN 1336 IMPACT STATE MACHINE FUNCTION BLOCK

## APPLICATION NOTE # 1336E - 7

August 27, 1997

---

### PURPOSE

The purpose of this document is to provide guidelines for wiring and control schemes for the Bulletin 1336 IMPACT AC Drive. This document is to be used as a suggestion only. Users must ensure that installations meet applicable codes and are suitable for the existing conditions.

The Bulletin 1336E User Manual should be used as a reference to ensure that proper wire selection, routing and fusing guidelines are followed. Refer to application note #1336E - 4 for an overview of Function Block concepts.

### WHAT THIS NOTE CONTAINS

This note contains descriptions and possible uses for the State Machine function block incorporated into the 1336E drive

### INTENDED AUDIENCE

This application note is intended to be used by personnel familiar with the hardware components and programming procedure necessary to operate the Bulletin 1336S.

### WHERE IT IS USED

The diagrams, parameter settings and auxiliary hardware used in this application note are designed to address specific issues in many different applications. Some changes by the User may be necessary to apply the concepts of this document to a specific application.

### TERMS AND DEFINITIONS

[ ] - Indicates a parameter name

Link - A link is a software connection between two parameters that lets one parameter receive information from another.

 - This represents a **source** which is a link parameter that provides the information.

 - This represents a **destination** which is a link parameter receiving the information.

### DESCRIPTION

The state machine block is a function generator. The signal at In1 is routed to a timer that delays the true/false state of this input. The result is logically compared with the true/false state of In2 to determine which one of four signals will be routed to the output. To configure the drive with the State Machine circuit the [Function Sel] parameter (212) must be programmed appropriately. Refer to figure 1.

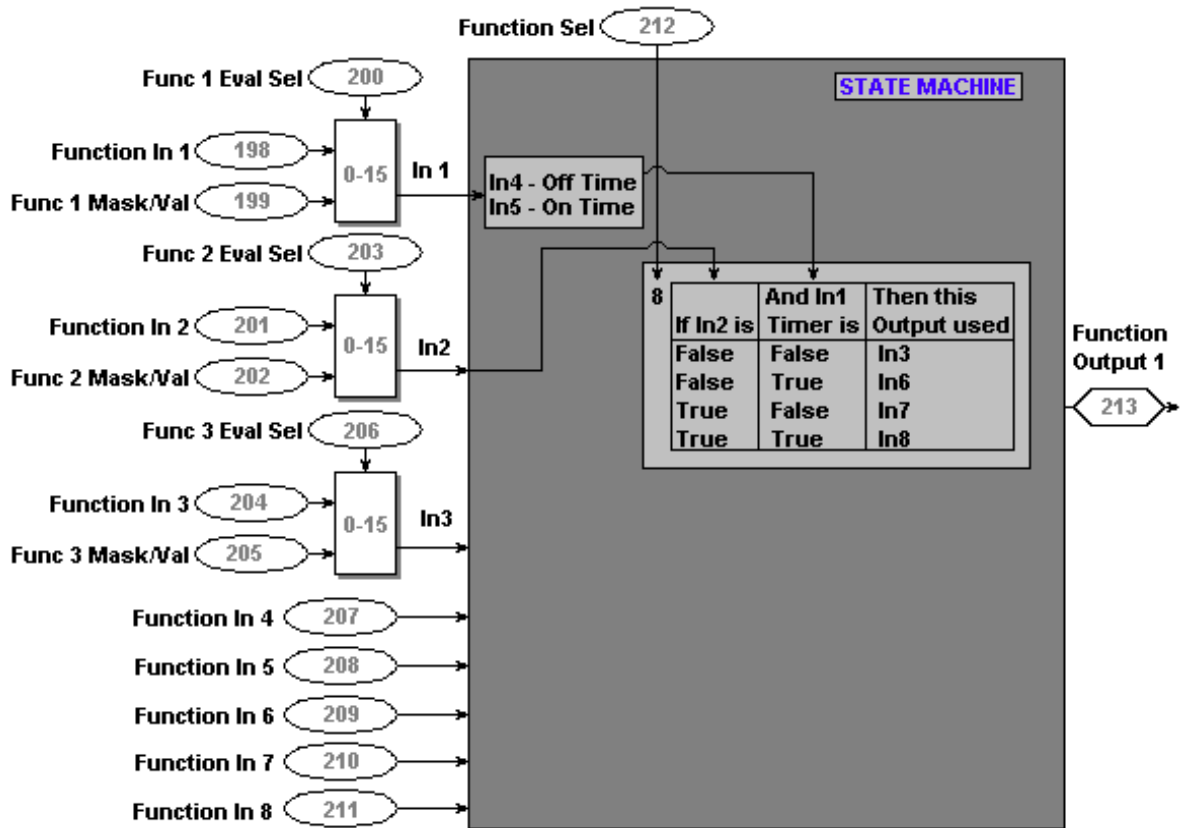

Figure 1

**EVALUATING THE FUNCTION INPUTS**

The “Function Evaluation Select” parameters (200,203,206) are used to precondition the inputs. The numbers 0-15 correspond to the 16 different evaluations available. Refer to table 1 for the descriptions.

Table 1

| VALUE | EVALUATION (1 = on = true = set = closed) (0 = off = false = reset = open)                        |
|-------|---|
| 0     | Pass the value directly through the function block  |
| 1     | Mask the value (logical AND the input value with a value)   |
| 2     | Send a true value when <b>all</b> bits that are set in the mask are <b>on</b> in the input value  |
| 3     | Send a true value when <b>all</b> bits that are set in the mask are <b>off</b> in the input value |
| 4     | Send a true value when <b>any</b> bits that are set in the mask are <b>on</b> in the input value  |
| 5     | Send a true value when <b>any</b> bits that are set in the mask are <b>off</b> in the input value |
| 6     | Send a true value when the input value is equal to the value of the mask                          |
| 7     | Send a true value when the input value is not equal to the value of the mask                      |
| 8     | Send a true value when the signed input value is < the value of the mask                          |
| 9     | Send a true value when the signed input value is < or = to the value of the mask                  |
| 10    | Send a true value when the signed input value is > the value of the mask                          |
| 11    | Send a true value when the signed input value is > or = to the value of the mask                  |
| 12    | Send a true value when the unsigned input value is < the value of the mask                        |
| 13    | Send a true value when the unsigned input value is < or = to the value of the mask                |
| 14    | Send a true value when the unsigned input value is > the value of the mask                        |
| 15    | Send a true value when the unsigned input value is > or = to the value of the mask                |

**State Machine**

When [Function Sel] is set to eight, the State Machine function will send In1 to an on/off delay timer circuit, then compare the true/false states of In1 and In2. One of the values at In3, In6, In7, or In8 become the output depending on the true/false state of both In1 and In2. Refer to figure 2.

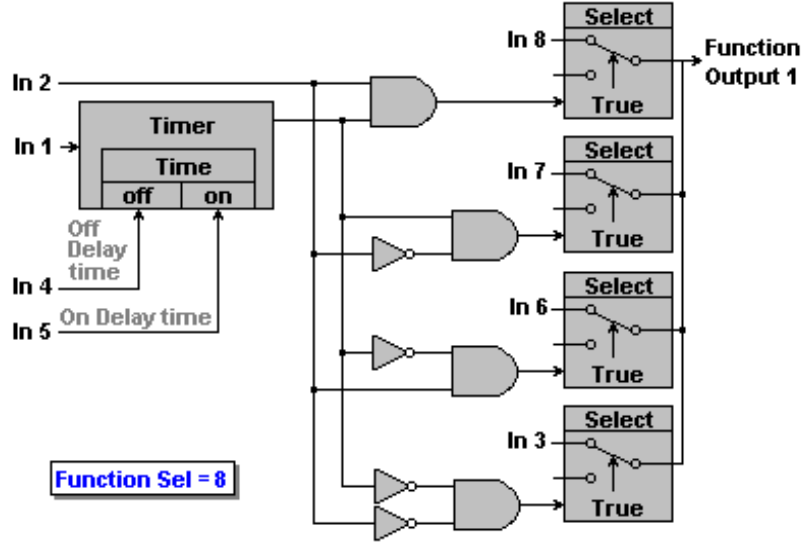

Figure 2

| If In2 is: | And In1 Timer is: | Output used is: |
|------------|-------------------|-----------------|
| True       | True              | In8             |
| True       | False             | In7             |
| False      | True              | In6             |
| False      | False             | In3             |

**APPLICATION CONSIDERATION**

The Function Input parameters for the state machine block are *linkable destination* type parameters. This means that other parameter values may be directly sent to, or linked, to these locations. All function inputs that are used by the function block must be programmed with a constant value or have a link.

The Function Output parameter is a *source* parameter. This parameter must be linked to a destination parameter.

The LINK menu of the Human Interface Module is used to create parameter links. An example of the link display is shown below.

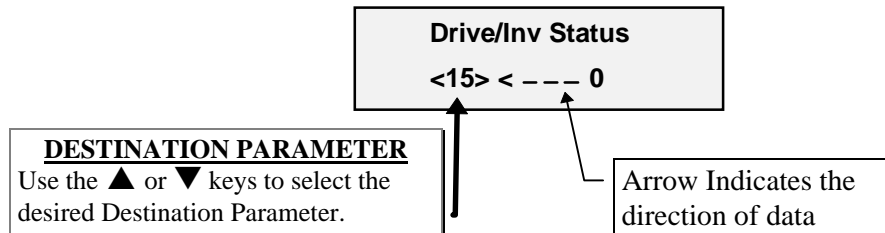

**APPLICATION  
 EXAMPLE**

The state machine block can be used to configure the drive for four different speed settings that are dependent upon the position of the machine that is being controlled. The input signals used in the example are simulating proximity switches on the machinery.

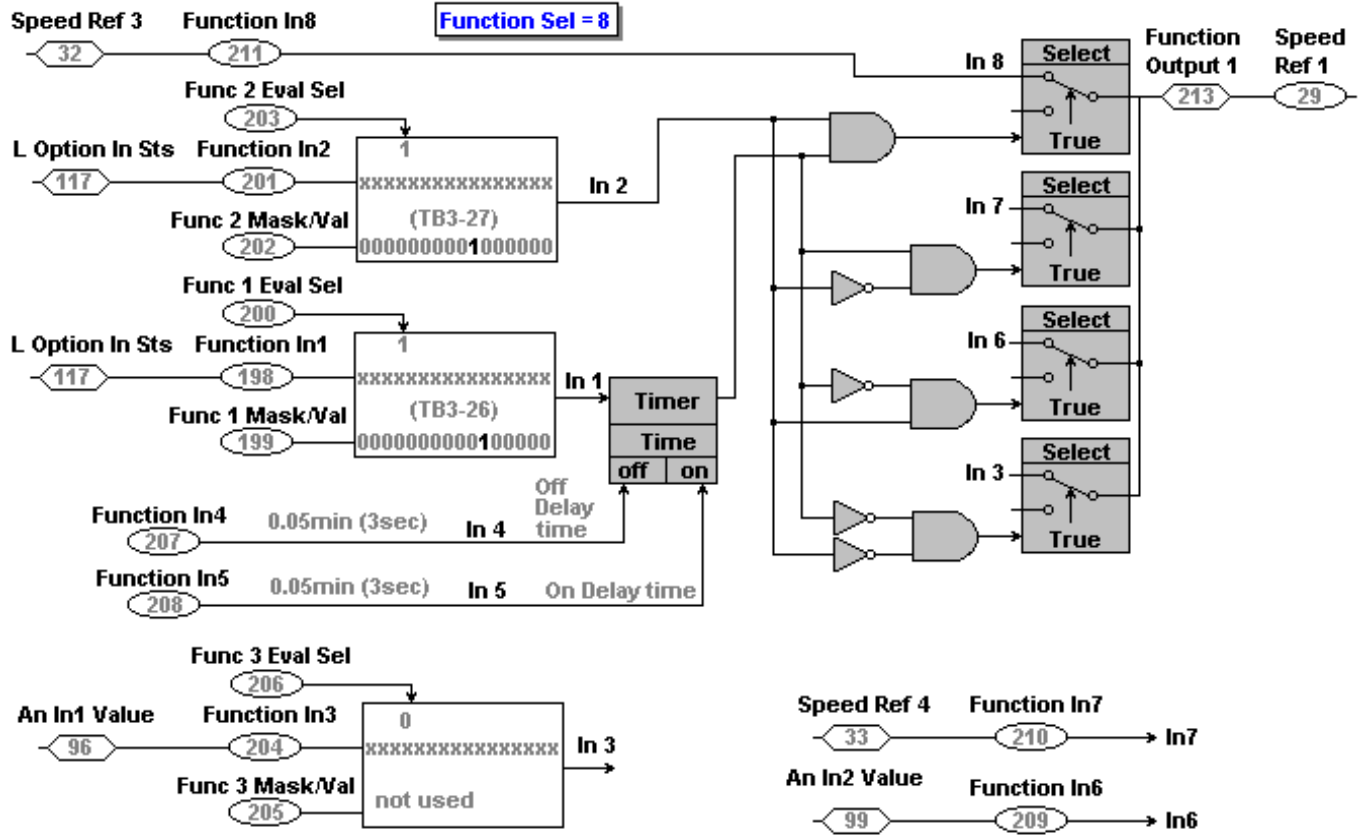

The following plot shows a function block setting four different command speeds based on two inputs. Our inputs happened to be switches to simulate either photo-eyes or other process switches. Below CH1 is switch1 input, CH2 is switch2 input, CH3 is speed feedback and CH4 is commanded speed.

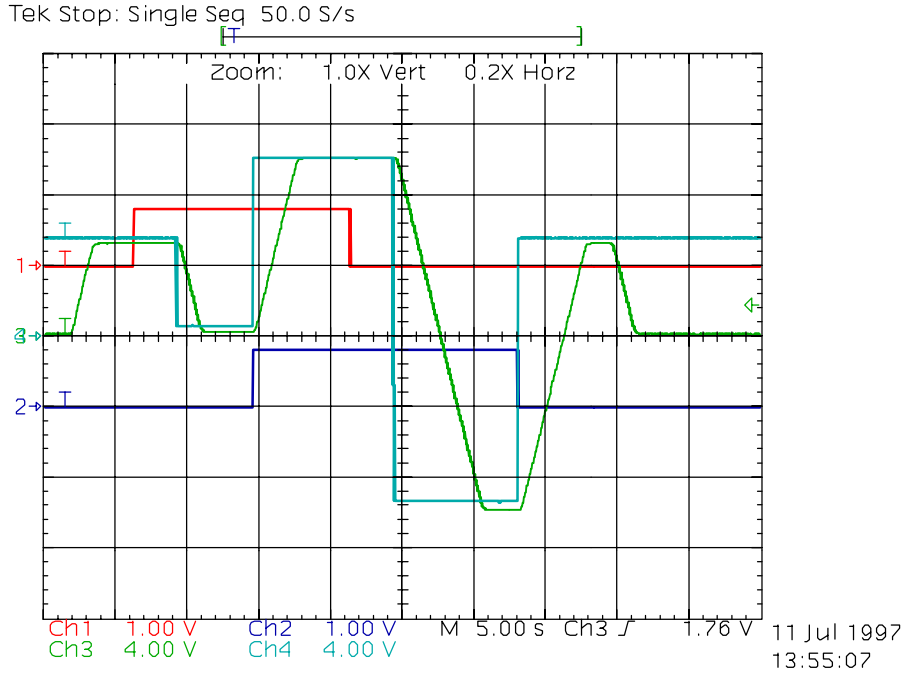

Here we can see the timing of the function block. 1.) Switch1 goes true and starts the timer for Input1. 2.) After 3 seconds the command speed is changed and the drive decel's to that speed. 3.) Switch2 goes true and the command speed is immediately changed since there is no timer on Input2 and the drive accel's to the commanded speed.

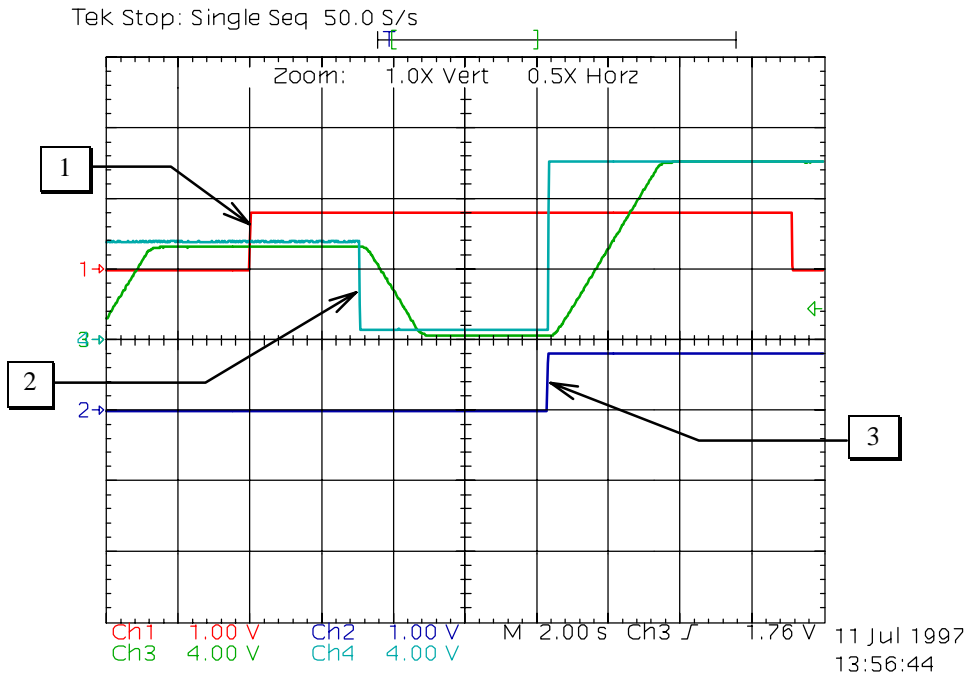

4.) Switch1 then goes false and 3 seconds later the command speed is set the third reference. 5.) Switch2 goes false and the command speed is changed to the fourth and original speed reference immediately since again there is no timer on Input2.

