



## **ALLEN-BRADLEY BULLETIN 1336 IMPACT ADD/SUBTRACT FUNCTION BLOCK**

**APPLICATION NOTE # 1336E - 8**

**August 27, 1997**

---

---

### **PURPOSE**

The purpose of this document is to provide guidelines for wiring and control schemes for the Bulletin 1336 IMPACT AC Drive. This document is to be used as a suggestion only. Users must ensure that installations meet applicable codes and are suitable for the existing conditions.

The Bulletin 1336E User Manual should be used as a reference to ensure that proper wire selection, routing and fusing guidelines are followed. Refer to application note #1336E - 4 for an overview of Function Block concepts.

### **WHAT THIS NOTE CONTAINS**

This note contains descriptions and possible uses for the Add/Subtract function block incorporated into the 1336E drive

### **INTENDED AUDIENCE**

This application note is intended to be used by personnel familiar with the hardware components and programming procedure necessary to operate the Bulletin 1336S.

### **WHERE IT IS USED**

The diagrams, parameter settings and auxiliary hardware used in this application note are designed to address specific issues in many different applications. Some changes by the User may be necessary to apply the concepts of this document to a specific application.

### **TERMS AND DEFINITIONS**

[ ] - Indicates a parameter name

Link - A link is a software connection between two parameters that lets one parameter receive information from another.

 - This represents a **source** which is a link parameter that provides the information.

 - This represents a **destination** which is a link parameter receiving the information.

### **DESCRIPTION**

The Add/Subtract function block is used to configure the drive with a signed addition circuit for two "function" inputs. To configure the drive with the Add/Subtract circuit the [Function Sel] parameter (212) must be programmed appropriately. Refer to figure 1.

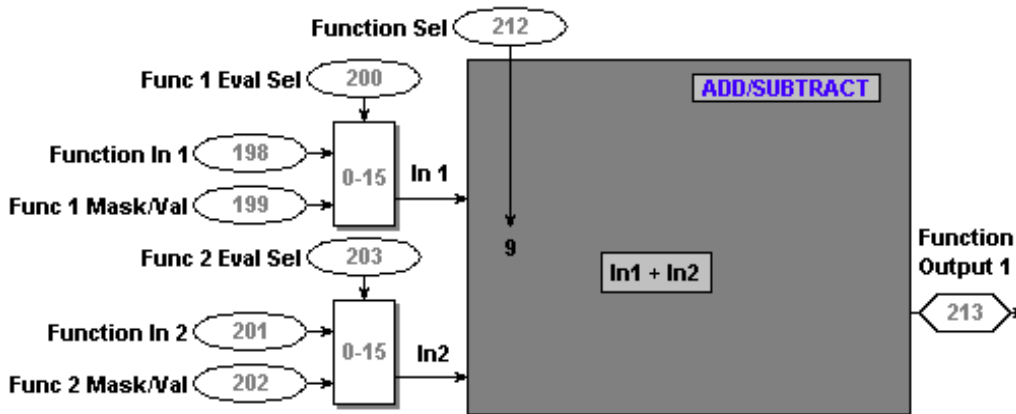

Figure 1

### EVALUATING THE FUNCTION INPUTS

The “Function Evaluation Select” parameters (200 and 203) are used to precondition the inputs. The numbers 0-15 correspond to the 16 different evaluations available. Refer to table 1 for the descriptions.

Table 1

VALUE	EVALUATION (1 = on = true = set = closed) (0 = off = false = reset = open)
0	Pass the value directly through the function block
1	Mask the value (logical AND the input value with a value)
2	Send a true value when <b>all</b> bits that are set in the mask are <b>on</b> in the input value
3	Send a true value when <b>all</b> bits that are set in the mask are <b>off</b> in the input value
4	Send a true value when <b>any</b> bits that are set in the mask are <b>on</b> in the input value
5	Send a true value when <b>any</b> bits that are set in the mask are <b>off</b> in the input value
6	Send a true value when the input value is equal to the value of the mask
7	Send a true value when the input value is not equal to the value of the mask
8	Send a true value when the signed input value is < the value of the mask
9	Send a true value when the signed input value is < or = to the value of the mask
10	Send a true value when the signed input value is > the value of the mask
11	Send a true value when the signed input value is > or = to the value of the mask
12	Send a true value when the unsigned input value is < the value of the mask
13	Send a true value when the unsigned input value is < or = to the value of the mask
14	Send a true value when the unsigned input value is > the value of the mask
15	Send a true value when the unsigned input value is > or = to the value of the mask

### Add/Subtract

When [Function Sel] is set to nine, the Add/Subtract function will add the values of In1 and In2 after the input mask is performed. (In3 - In8 are not used)

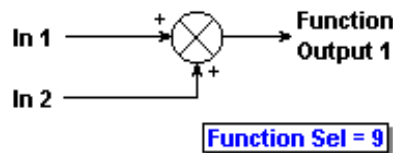

**APPLICATION  
 CONSIDERATION**

The Function Input parameters for the add/subtract block are *linkable destination* type parameters. This means that other parameter values may be directly sent to, or linked, to these locations. All function inputs that are used by the function block must be programmed with a constant value or have a link.

The Function Output parameter is a *source* parameter. This parameter must be linked to a destination parameter.

The LINK menu of the Human Interface Module is used to create parameter links. An example of the link display is shown below.

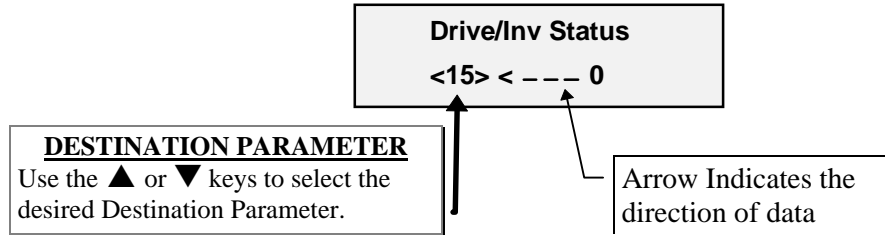

**APPLICATION  
 EXAMPLE**

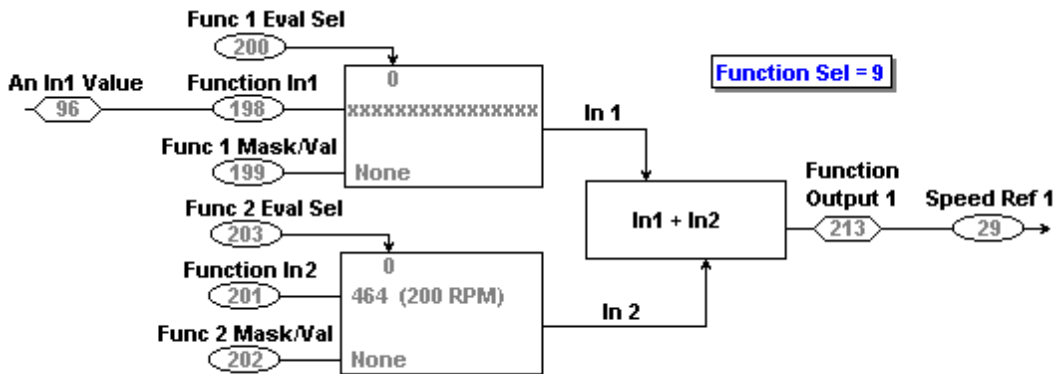

Ch1 is the function block output1. Ch2 is actual speed. Ch3 is speed adder In2. Ch4 is speed pot. In this example we are adding 200rpm to the speed command.

1.) As soon as the drive is started the speed immediately goes to 200rpm. Note that the speed potentiometer is at zero. 2.) Now the drive follows the speed pot as normal with 200rpm added. 3.) As the drive gets to full speed there is some dead time in the potentiometer. This is easier to see as the speed is decreased. 4.) Note the analog potentiometer signal coming down and the actual speed not changing until the 200rpm adder is consumed. 5.) The drive is stopped.

