



ALLEN-BRADLEY BULLETIN 1336 IMPACT UP/DOWN COUNTER FUNCTION BLOCK

APPLICATION NOTE # 1336E - 10

August 28, 1997

PURPOSE

The purpose of this document is to provide guidelines for wiring and control schemes for the Bulletin 1336 IMPACT AC Drive. This document is to be used as a suggestion only. Users must ensure that installations meet applicable codes and are suitable for the existing conditions.

The Bulletin 1336E User Manual should be used as a reference to ensure that proper wire selection, routing and fusing guidelines are followed. Refer to application note #1336E - 4 for an overview of Function Block concepts.

WHAT THIS NOTE CONTAINS

This note contains descriptions and possible uses for the Up/Down Counter function block incorporated into the 1336E drive

INTENDED AUDIENCE

This application note is intended to be used by personnel familiar with the hardware components and programming procedure necessary to operate the Bulletin 1336S.

WHERE IT IS USED

The diagrams, parameter settings and auxiliary hardware used in this application note are designed to address specific issues in many different applications. Some changes by the User may be necessary to apply the concepts of this document to a specific application.

TERMS AND DEFINITIONS

[] - Indicates a parameter name

Link - A link is a software connection between two parameters that lets one parameter receive information from another.

 - This represents a **source** which is a link parameter that provides the information.

 - This represents a **destination** which is a link parameter receiving the information.

DESCRIPTION

The Up/Down Counter function block is used to configure the drive with a counter circuit that increments or decrements based upon the programmed "function" inputs. To configure the drive with the Up/Down Counter circuit the [Function Sel] parameter (212) must be programmed appropriately. Refer to figure 1.

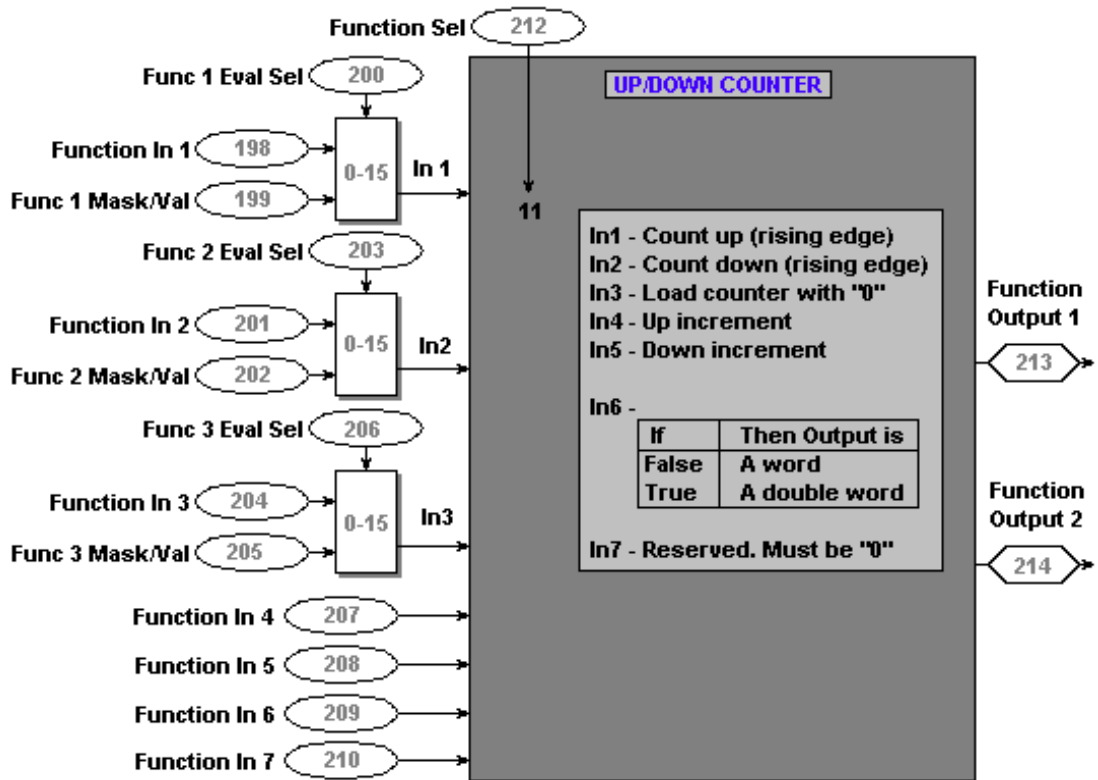

Figure 1

EVALUATING THE FUNCTION INPUTS

The "Function Evaluation Select" parameters (200,203,206) are used to precondition the inputs. The numbers 0-15 correspond to the 16 different evaluations available. Refer to table 1 for the descriptions.

Table 1

VALUE	EVALUATION (1 = on = true = set = closed) (0 = off = false = reset = open)
0	Pass the value directly through the function block
1	Mask the value (logical AND the input value with a value)
2	Send a true value when all bits that are set in the mask are on in the input value
3	Send a true value when all bits that are set in the mask are off in the input value
4	Send a true value when any bits that are set in the mask are on in the input value
5	Send a true value when any bits that are set in the mask are off in the input value
6	Send a true value when the input value is equal to the value of the mask
7	Send a true value when the input value is not equal to the value of the mask
8	Send a true value when the signed input value is < the value of the mask
9	Send a true value when the signed input value is < or = to the value of the mask
10	Send a true value when the signed input value is > the value of the mask
11	Send a true value when the signed input value is > or = to the value of the mask
12	Send a true value when the unsigned input value is < the value of the mask
13	Send a true value when the unsigned input value is < or = to the value of the mask
14	Send a true value when the unsigned input value is > the value of the mask
15	Send a true value when the unsigned input value is > or = to the value of the mask

Up/Down Counter

When [Function Sel] is set to eleven, the Up/Down Counter function is used to increment or decrement the output. A rising edge at In1 increments the count by the value of In4, while In2 decrements the count by the value of In5. In3 is used to reset the counter. The logical state of In6 determines if the output is a single or double word (In7 and In8 are not used). Refer to figure 2.

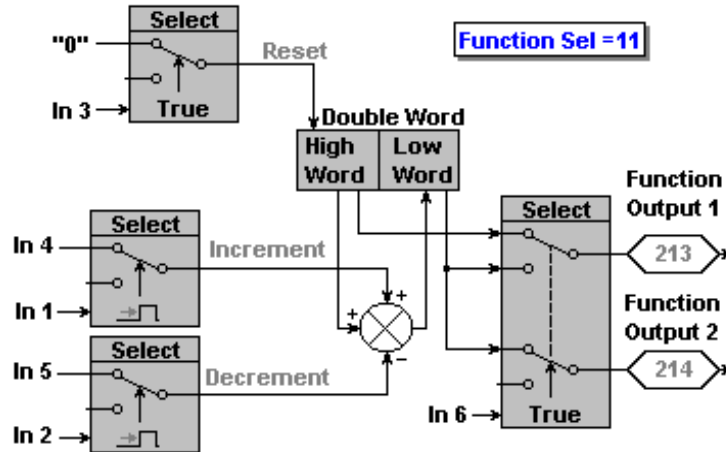

Figure 2

APPLICATION CONSIDERATION

The Function Input parameters for the up/down counter block are *linkable destination* type parameters. This means that other parameter values may be directly sent to, or linked, to these locations. All function inputs that are used by the function block must be programmed with a constant value or have a link.

The Function Output parameter is a *source* parameter. This parameter must be linked to a destination parameter.

The LINK menu of the Human Interface Module is used to create parameter links. An example of the link display is shown below.

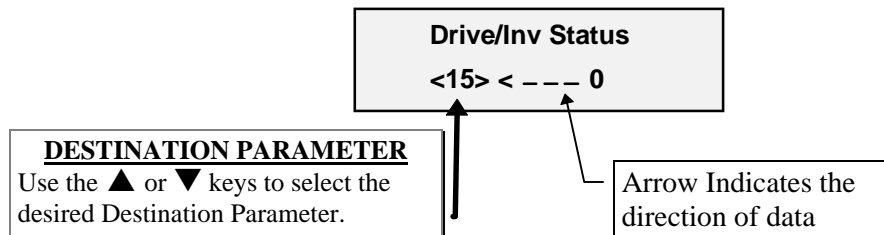

APPLICATION EXAMPLE

The following example uses the up/down counter to change the speed reference in precise increments. Three push buttons wired to TB3-26, 27 and 28 perform the increment, decrement, and reset functions.

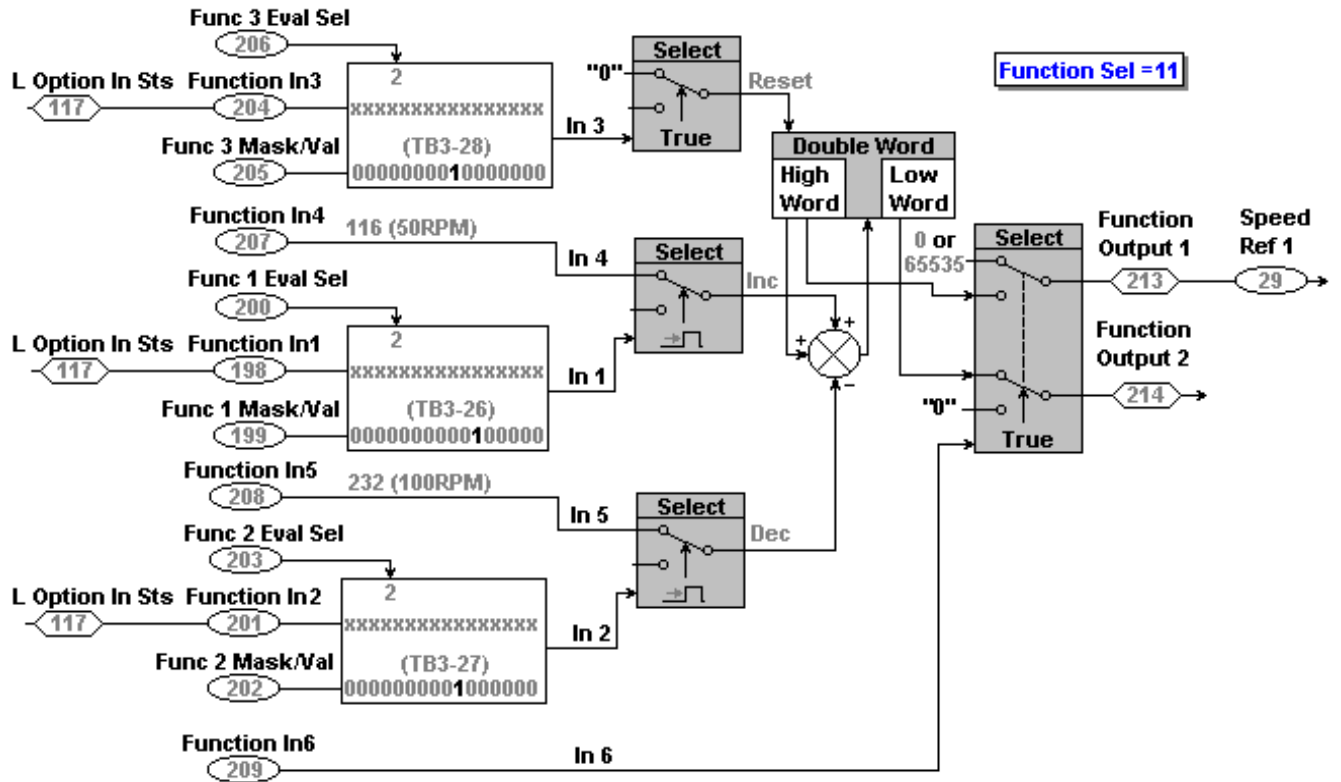

In this example we simulate a precise MOP function. As the increase push-button is pressed the speed will increment an exact value each time regardless of how long the push-button is depressed. The same for the decrease push-button. Each depression of the push-button will decrease the speed and exact value. There was also a reset function wired in.

Ch1 is the reset push-button. Ch2 is the increase push-button. Ch3 is decrease push-button. Ch4 is speed command.

- 1.) The increase push-button is pressed and the speed command increments in a fixed value.
- 2.) Here the reset push-button is pressed. The speed command resets to zero speed.
- 3.) The decrease push-button is pressed and the speed command falls off in another fixed value.

