

## Installation and Wiring

### Chapter Objectives

Chapter 2 provides information on mounting the PLC Comm Adapter Board as well as configuring and connecting communications.

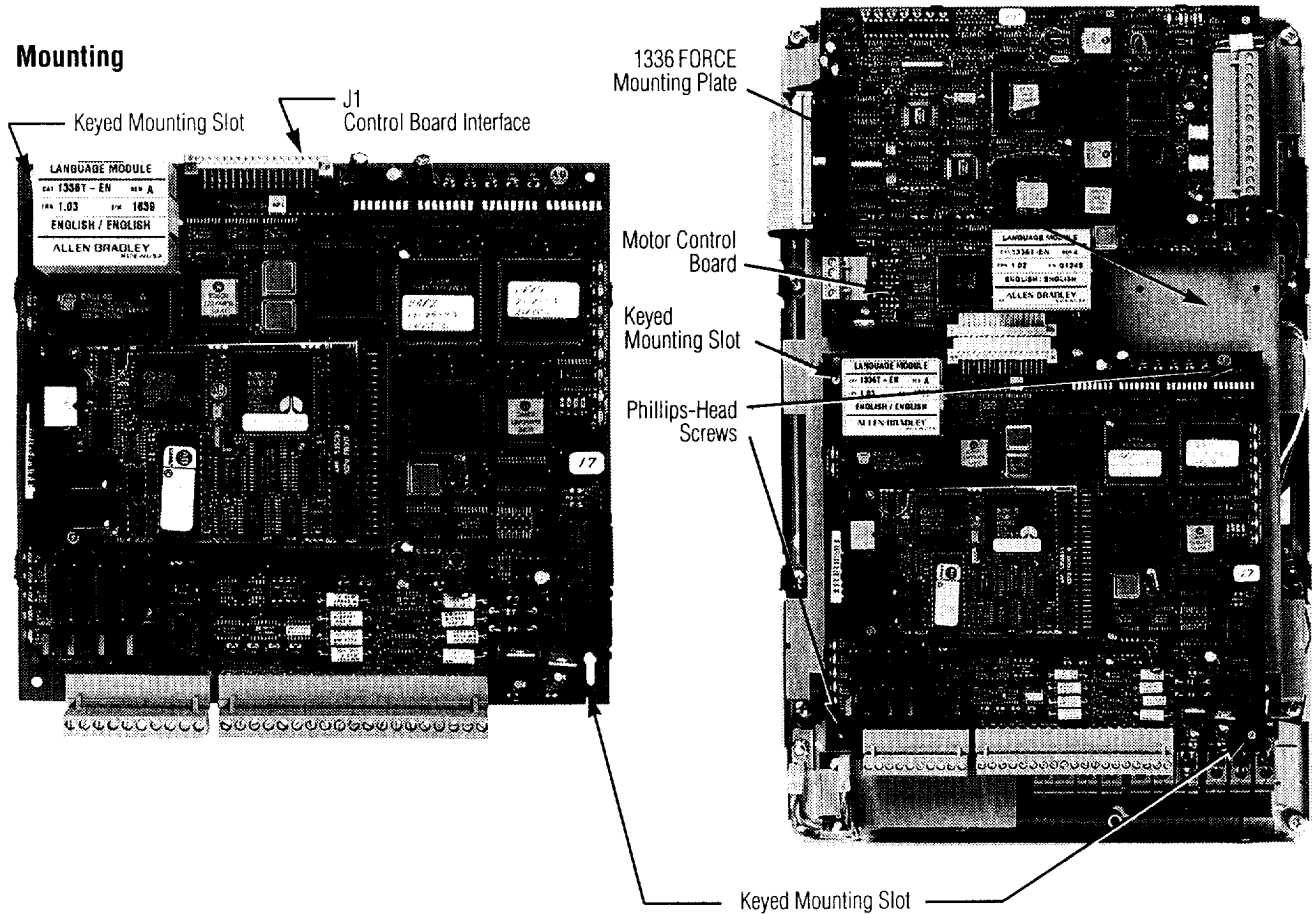

**Figure 2-1 — PLC Comm Adapter Board Mounting**

The PLC Comm Board plugs into the Main Control Board at connector **JL**. (2) Keyed Mounting Slots along with the (2) Phillips-Head Screws provided with the kit secure the board to the 1336 FORCE Mounting Plate.

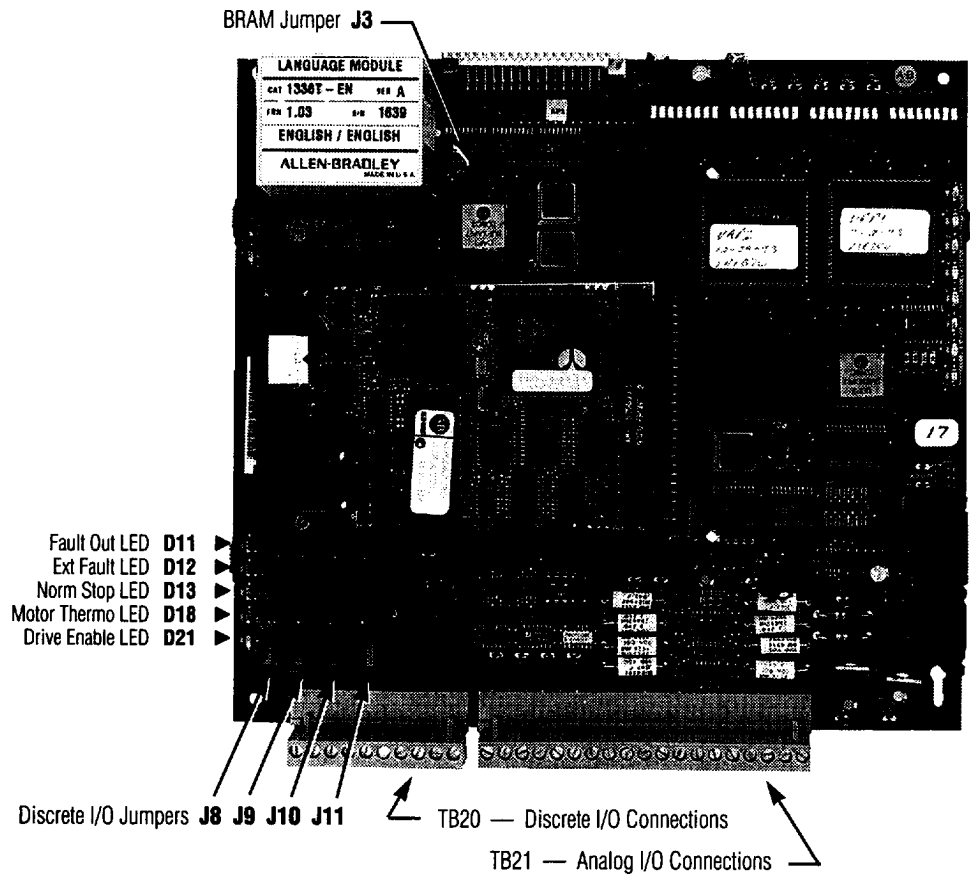
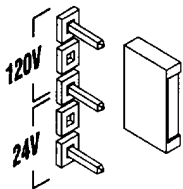

Figure 2-2 - PLC Comm Adapter Board Terminal Blocks and Discrete I/O Jumpers

### Discrete I/O Jumpers



**ATTENTION:** To avoid damage to the PLC Comm Adapter Board, discrete Input Jumpers **J8**, **J9**, **J10** and **J11** must be set to the same input voltage applied to the PLC Comm Adapter Board - Either 24V DC or 120V AC.

**J8** Sets the Drive Enable input for either 24V DC or 120V AC. **J9** Sets the Motor Thermoguard input for either 24V DC or 120V AC. **J10** Sets the Norm Stop input for either 24V DC or 120VAC. **J11** Sets the External Fault input for either 24VDC or 120VAC.

### BRAM Jumper

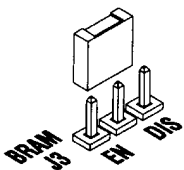

Jumper **B** on the PLC Comm Adapter Board enables or disables the write to **BRAM** function as follows. **EN** Enabled - Write to **BRAM** is allowed. **DIS** Disabled - Write to **BRAM** is not allowed.

**Terminal Block Locations**

Two separate terminal blocks are provided at the bottom of the PLC Comm Adapter Board for discrete and analog I/O wiring. To aid in making connections, terminal blocks may be pulled apart when connecting cable. The maximum and minimum wire size accepted by both TB20 and TB21 is 3.3 & 0.60 mm<sup>2</sup> (12 & 30 AWG). Maximum torque is 0.79 N-m (7 lb-in). Recommended control signal wire is:  
 Belden 8760 or equiv. - 0.750 mm<sup>2</sup> (18 AWG), Twisted Pair, Shielded  
 Belden 8770 or equiv. - 0.750 mm<sup>2</sup> (18 AWG), 3-Conductor, Shielded  
 Belden 9460 or equiv. - 0.750 mm<sup>2</sup> (18 AWG), Twisted Pair, Shielded

**Discrete I/O**

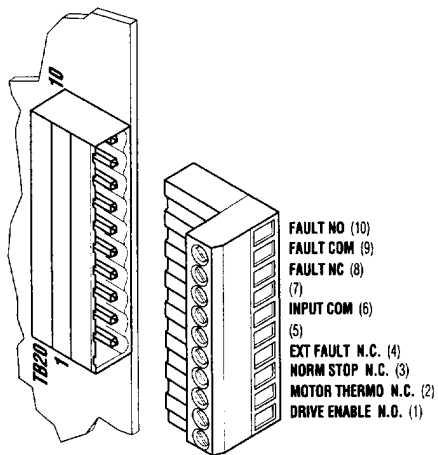

**Discrete Outputs**

Fault outputs from the 1336 FORCE are supplied at terminal block TB20 on the PLC Comm Board. Fault outputs provide warning or fault signals based on drive programming.

**FAULT NC**

**FAULT COM**

**FAULT NO** - A Form C, N.O./N.C. relay contact on the PLC Comm Board programmed to provide external warning or fault change-of-state signals.

Resistive Rating = 115V AC/30V DC, 5.0 A

Inductive Rating = 115V AC/30V DC, 5.0 A

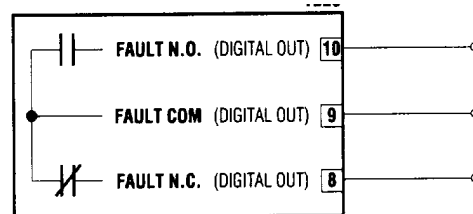

**Figure 2-3 — Typical Digital Output Connections**

**Discrete Inputs**

Discrete Inputs to the 1336 FORCE are supplied through the PLC Comm Adapter Board at terminal block TB20. Discrete inputs serve to enable and stop the drive as well as provide checks on drive and motor operation.

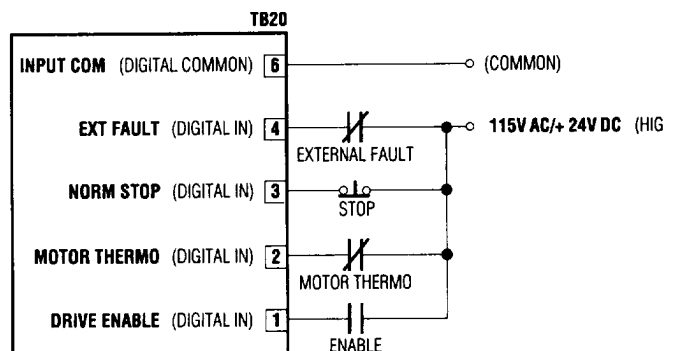

**Figure 2-4 - Typical Digital Input Connections Using an External Power**

**DRIVE ENABLE** - A drive enable signal must be present before the drive will acknowledge a start command. If LED D21 Drive Enable on the PLC Comm Board is illuminated, the drive has received an enable signal allowing drive logic to accept a start command.

**MOTOR THERMO** - Allows the user to connect a N.C. motor thermal switch to the 1336 FORCE. Motor Thermo LED D18 on the PLC Comm Adapter will illuminate if a motor over temperature condition occurs. The drive will issue a warning or trip on a fault as configured by Parameter 88 (VP Flt/Warn Cfg) and Parameter 89 (VP Warn/None Cfg).

**NORM STOP** - A N.C. maintained stop input that will stop the drive according to the user specified stop mode (Parameter 59). The drive responds the same way it would if the stop bit were set in any logic command. When a stop signal is present, the Norm Stop LED D13 on the PLC Board will be illuminated, and the drive will not be allowed to run until the stop signal is removed.

**ATTENTION:** The drive start/stop control circuitry includes solid-state components. If hazards due to accidental contact with moving machinery or unintentional flow of liquid, gas or solids exist, an additional hardwired stop circuit is required to remove AC line power to the drive. When AC input power is removed, there will be loss of inherent regenerative braking effect and the motor will coast to a stop. An auxiliary braking method may be required.

**EXT FAULT** - Allows the user to wire an external signal into the 1336 FORCE. If external fault input voltage is removed, the External Fault LED D12 on the PLC Board will light. The drive will then issue a fault or warning based on the fault configuration defined by Parameters 88 and 89. When input voltage is applied, D12 will not be lit.

**Analog Inputs**

There are (4) analog inputs to the PLC Comm Adapter Board that have a range of  $\pm 10V$  and a digital resolution of 12 bits. These inputs are differential inputs with noise rejection filtering.

Each input has a gain and offset adjustment. The A/D converter is a 12 bit device where an input value of +10V will result in a digital value of 2048. Likewise, an input value of -10V will result in a digital output value of -2048. Chapter 4 describes the parameters associated with scaling analog values. Note: Analog input parameters must be linked to a velocity reference parameter as well as a scaling and offset parameter for an analog input to function.

**Analog Outputs**

There are (4) analog outputs from the PLC Comm Adapter Board that have a range of  $\pm 10V$  and a digital resolution of 12 bits. Chapter 4 describes the parameters associated with scaling analog values.

**Analog I/O Connections**

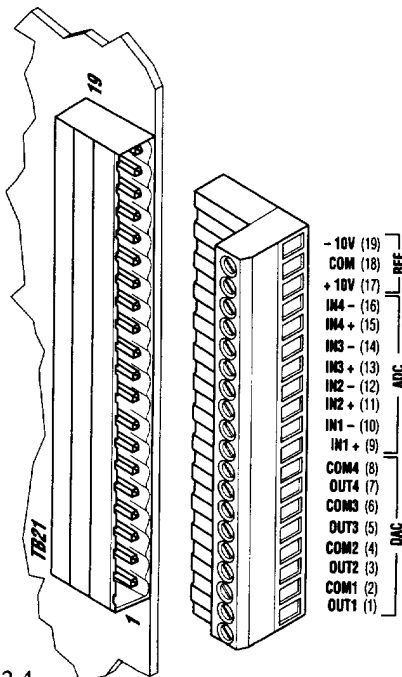

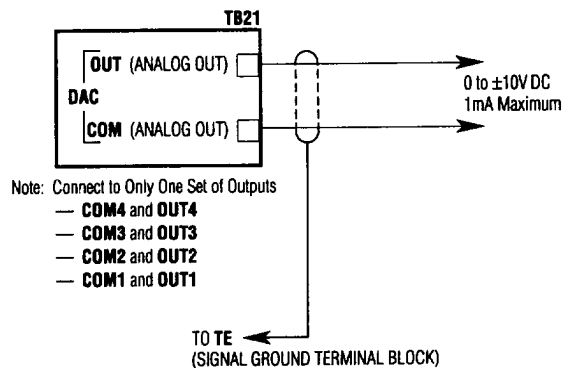
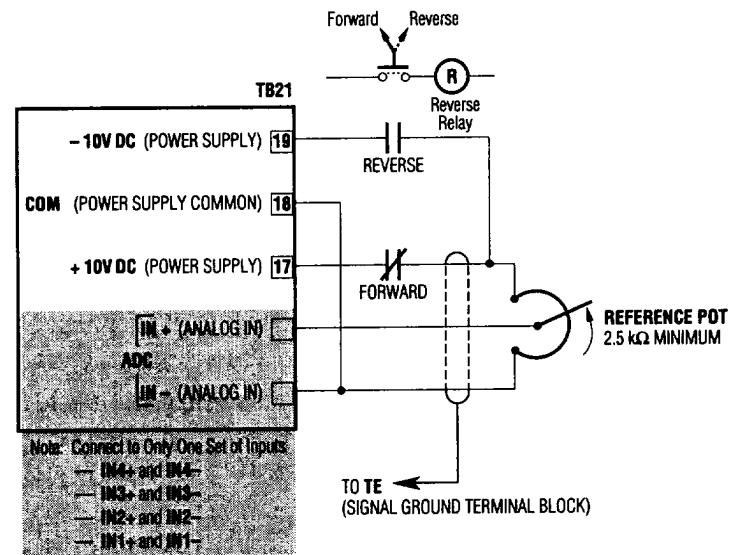
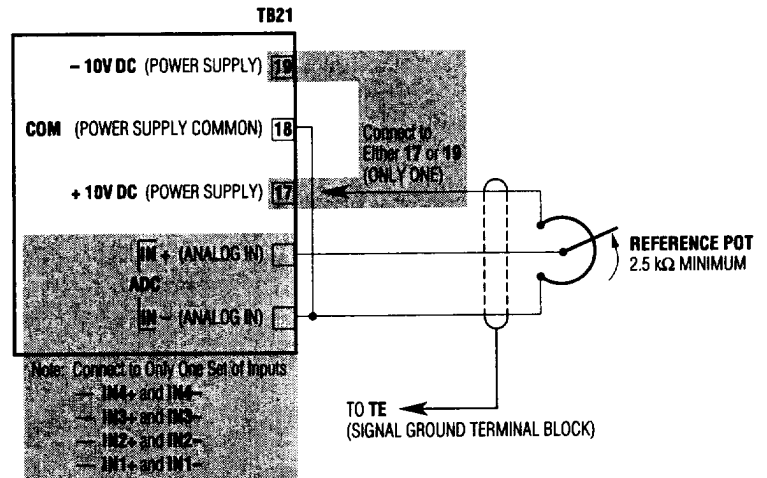

**Figure 2-7 — Typical Analog Output Connections**

## RIO and DH+ Configuration

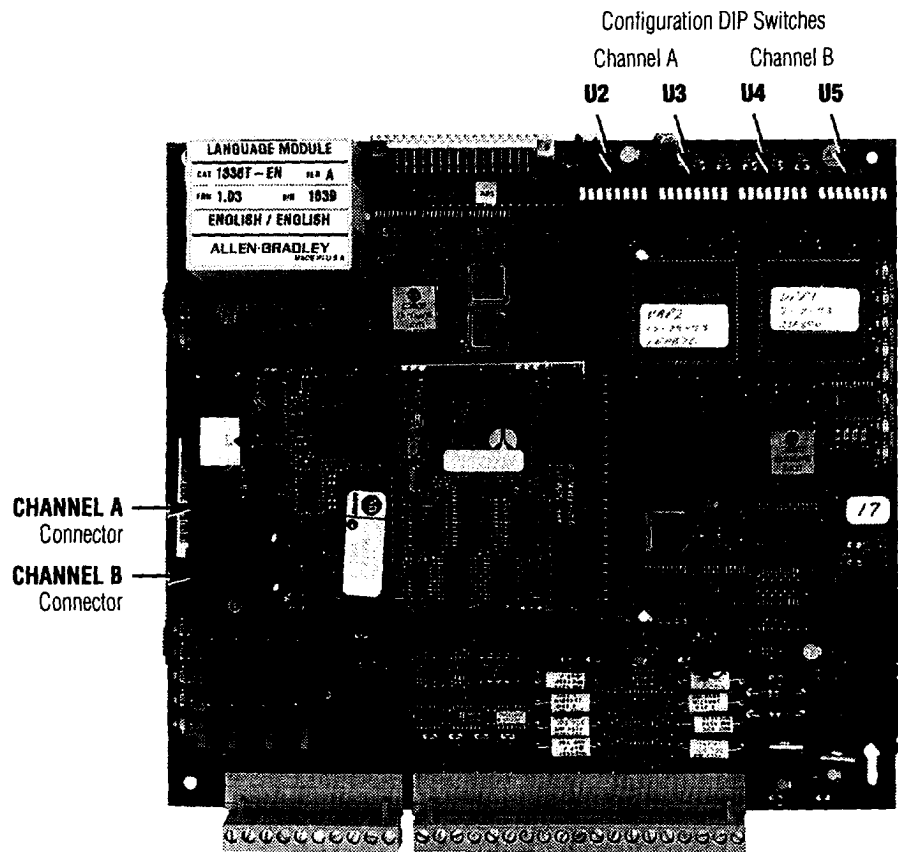
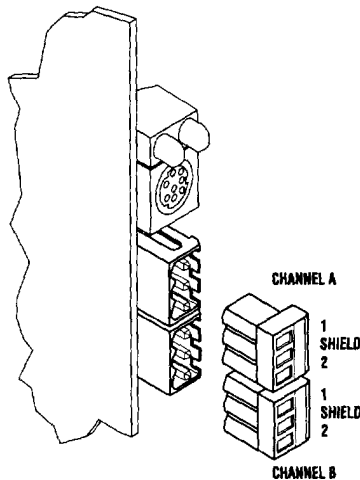

Figure 2-8 — PLC Comm Adapter Board DIP Switches and Communication Connections

### Port Wiring



Twinaxial cable is used to connect Channel A or B of the PLC Comm Adapter Board to RIO and DH+ communications systems as shown in Figures 2-9 and 2-10.

#### CABLE TYPE

Belden 9463 - Consult Allen-Bradley if any other type cable is used.

#### CABLE LENGTH

A minimum of 10 feet for all connections. Shorter lengths may cause signal reflections.

#### CABLE CONNECTIONS

##### CONNECTIONS

All (3) conductors - Blue, Shield and Clear - should be connected at each wiring point. No additional ground connections should be made to the shield.

**Important:** Do not use star type connections. Only (2) cables may be connected at any wiring point on a series connected application.

#### CABLE TERMINATIONS

(2) 1770-XT or 150K2 (820 for 230 kbaud) resistors are used for cable termination. Use (1) at each end of the cable.

**Communication Configuration** Connections to Allen-Bradley's RIO or DH+ networks are made via (2) channels (Channel A or Channel B) on the PLC Comm Adapter Board. Each channel allows the 1336 FORCE to communicate directly with a PLC and is independently programmable. Dip switch settings on the PLC Comm Adapter Board are used to configure one or both channels for DH+ or RIO communication. Switches U2 and U3 are used to configure Channel A, switches U4 and U5 are used to configure Channel B. A detailed explanation of DIP switch settings is provided in Chapter 3 - Start-Up.

### RIO Configuration

When a communication channel is configured for RIO connection, the PLC Comm Adapter Board will look like a remote I/O rack to an Allen Bradley PLC.

The PLC Adapter can:

- Support 57.6K, 115K or 230K baud communication rates.

- Be configured as a 1/4, 1/2, 3/4 or full I/O rack.

- Be configured to ignore PLC fault conditions and continue operating.

- Support transfer of multiple drive parameter read or writes in a single Block Transfer.

- Allow the 1336 FORCE to be directly connected to (2) PLCs. PLC parameter control allows drive control to be switched between the two PLCs and specifies which PLC is currently in control.

- Allow the Block Transfer feature to be disabled via DIP switch setting and provide an extra word of discrete data.

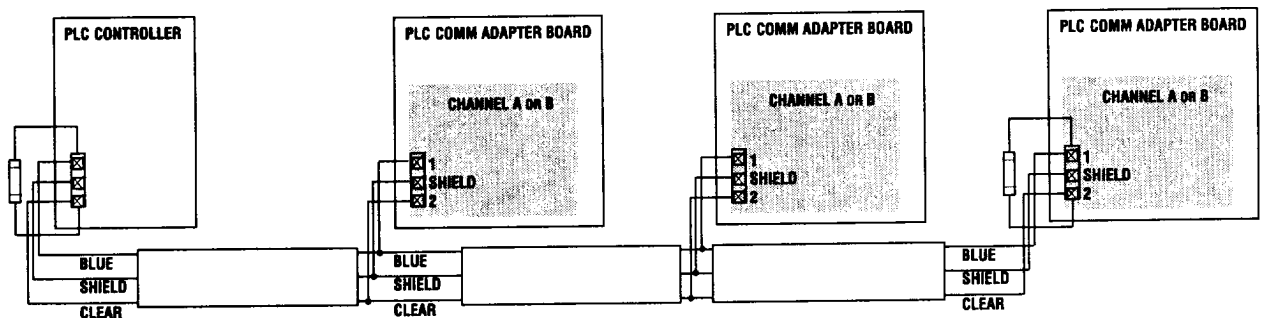

Figure 2-9 — RIO Wiring Configuration

## DH+ Configuration

When a communication channel is configured for DH+ communication, the PLC Adapter Board becomes a station on the DH+ link. Information can be passed to and from the drive using the DH+ protocol.

The PLC Adapter can:

- Support 57.6K, 115K or 230K baud communication rates.
- Support read or write messages for blocks of parameters.
- Allow the PLC to issue 1336 FORCE messages using a method similar to RIO Block Transfer.

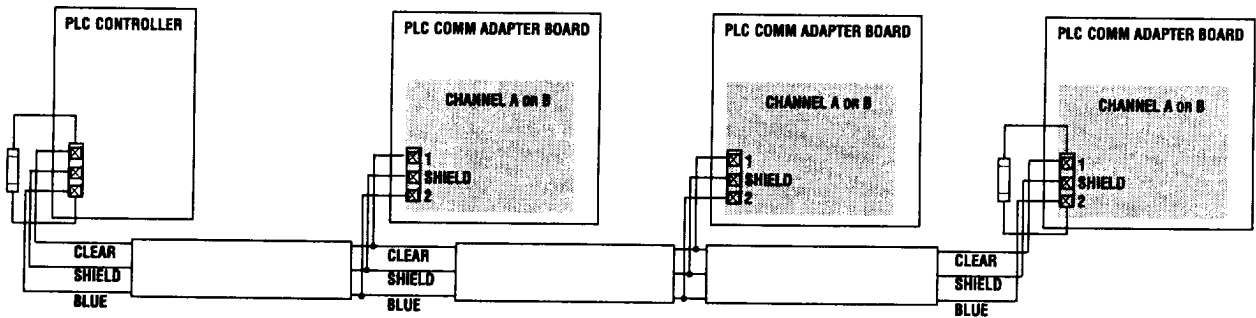

Figure 2-10 — DH+ Wiring Configuration