

## Bulletin 1365 Installation Guide

**ATTENTION:** The user is responsible for conforming to the National Electrical Code and all other applicable local codes. Failure to comply with codes could result in severe bodily injury or loss of life.

**ATTENTION:** This equipment is at line voltage when AC power is connected. Disconnect and lockout all ungrounded conductors of the AC power line. Failure to observe these precautions could result in severe bodily injury or loss of life.

Note: All remote operation wiring must not exceed 250 feet.

### Ground the Controller and Enclosure, the Motor and the Operator Control Station

**ATTENTION:** Connect the ground wire brought in with the incoming AC power line to the controller ground point. Connect an appropriate equipment grounding conductor unbroken from the controller ground point, the motor frame, the transformer enclosure if used, the controller electrical enclosure, the wiring conduits, and the operator's control station to an appropriate grounding electrode. Failure to observe this precaution could result in severe bodily injury or loss of life.

1. Locate the ground point provided at the bottom edge of the heat sink.
2. Run a suitable equipment grounding conductor unbroken from this controller ground point to the plant ground (grounding electrode). A ring lug is required at the ground point.
3. Connect a suitable grounding conductor from each conduit to this controller ground point.
4. Connect a suitable equipment grounding conductor to the motor frame, the transformer enclosure if used, and the controller enclosure. Run this conductor unbroken to the grounding electrode.
5. Connect the ground wire brought in with the incoming AC power line to the controller ground point.

### Wiring AC Power to the Controller

**ATTENTION:** Do not operate the controller with available short-circuit currents in excess of 10,000 amperes. Failure to observe this precaution could result in severe bodily injury or loss of life.

1. Size the AC line supply conductors for the specific controller rating and according to all applicable codes.
2. Run the AC line supply through a conduit entry in the bottom of the controller to terminals TB1L1 and TB1-L2/F1.

### Wiring the DC Motor to the Controller

1. Size the motor armature circuit conductors A1 and A2 according to all applicable codes.
2. Run the DC motor armature leads and the shunt field supply leads (if a permanent magnet field motor is not used) through the same conduit entry used for the AC line supply.
3. Use the appropriate tightening torque as listed in Table JA for wire connections to input and output terminals.

**Table 1.A. Terminal Strip TB1/TB2 Tightening Torquês (lbs-in).**

TB	Terminals	Torque
TB1	Input Terminals 51, L1, L2/F2	All: 9 minimum -
TB2	Output Terminals A1, A2/F2	12 maximum in-lbs
TB1	Thermostat 32, 132	4 in-lbs

**ATTENTION:** If motors other than a straight shunt are used with the 1365 controller and an S1 and S2 winding is present on the motor, additional motor connections other than those detailed in this instruction manual are applicable. Refer to the motor manufacturer instructions when wiring other types of motor. Failure to observe this precaution could result in damage to the equipment.

- For ALL Catalogs (except 1365-DAF): If CCW motor rotation is desired (looking from the back of the motor or the shaft end), connect motor armature leads A1 and A2 to controller terminals TB1-A1 and TB1-A2/F2, respectively, as shown in Figure 1.1. If CW motor rotation is desired (looking from the back of the motor or the shaft end), reverse the motor armature connections at the motor.

For 1365-DAF ONLY, if CCW motor rotation is desired when the Forward/Off/Reverse switch is in the FORWARD position (looking from the back of the motor or the shaft end), connect motor armature leads A1 and A2 to controller terminals TB3-A1 and TB3-A2, respectively. If CW motor rotation is desired (looking from the back of the motor or the shaft end), reverse the motor armature connections at the motor.

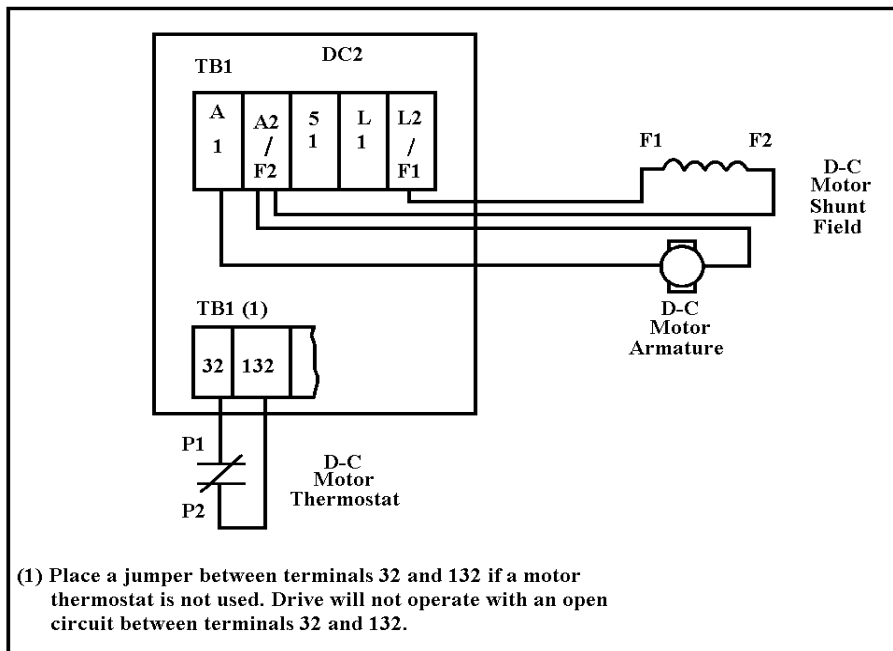

**Figure 1.1 Armature, Field and Thermostat ( CCW Rotation ) Connections.**

- Connect the motor shunt field supply (when available) leads F1 and F2 to controller terminals TB1-L2/F1 and A2/F2, respectively. See Figure 1.1.
- Verify that the field is connected as shown on the motor nameplate or the connection diagram in the terminal box on the motor.

7. Connect the motor thermostat leads P1 and P2 to controller terminal TB2-32 and TB2-132, respectively. See Figure 1.1. If a motor thermostat is not used, another means of motor overload thermal protection must be used and a jumper must be placed between terminals 132 and 32 on TB2.

### Wiring the Start/Stop Circuit

For drives without operator devices on the controller (Catalog 1365-SAN, 1365-PAN, 1365-TAN):

1. Run the Start/Stop push-button or normally open contact wiring in the remaining conduit entry separate from the AC and DC power wiring.

**ATTENTION:** The factory installed jumper must be removed from between controller terminals 51 and L1 if the stop switch is to be wired to these terminals. Failure to observe this precaution could result in bodily injury. A maintained closed contact can cause the controller to automatically restart if line input power is removed and then re-applied. Do not use a maintained contact unless the machine is suitably protected. Failure to observe these precautions could result in bodily injury.

2. Use the appropriate tightening torque as listed in Table 1.B for wire connections to input and output terminals.

**Table 1.B. Terminal Strip TB/TB4 Tightening Torques (lbs-in).**

TB	Terminals	Torque
TB2	32, 132, 35, 38, 419, 519, 326, 156, 157, 126	4 in-lbs
TB4	6+, 5-	4 in-lbs

3. Connect the Start/Stop push-button or normally open contact as shown in Figure 1.2.
4. If Start/Stop control is remote, remove the factory-installed jumper between terminals TB2-35 and TB2-132. See Figure 1.2. With the operator's Start/Stop controls mounted remotely from the controller, the AC fused disconnect or circuit breaker must be mounted in close proximity to the operator controls.

**ATTENTION:** A start/stop switch that does not include an AC power disconnect function in the Stop position is not recommended for use with the 1365 drive. The 1365 drive does not have an armature loop contactor and a single fault like a thyristor short could cause motor rotation when in the stop mode, if used with a switch that did not disconnect AC power. If a Start/Stop switch without a power disconnect function is used, an AC power disconnect switch MUST be mounted next to the operator controls. Failure to observe this precaution could result in bodily injury.

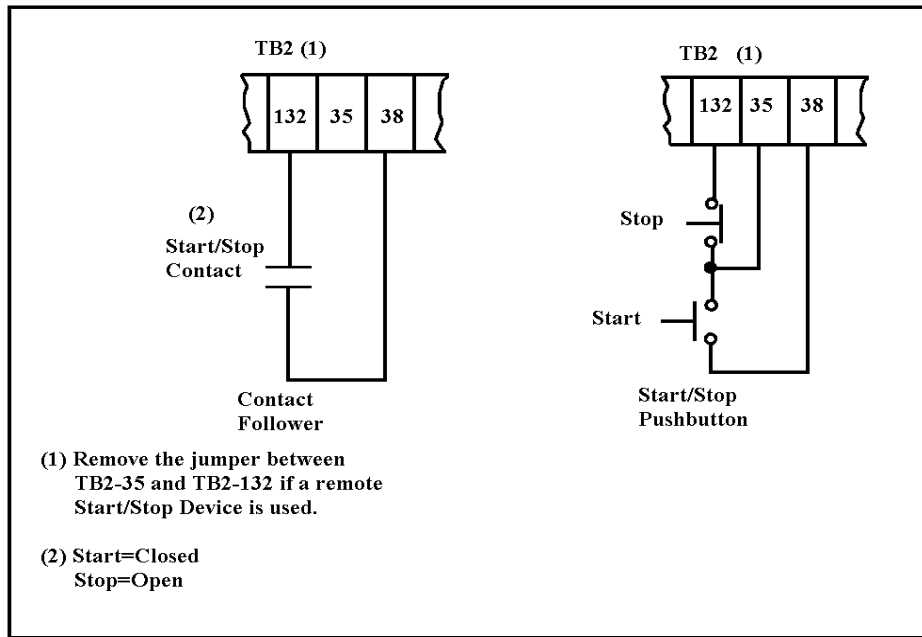
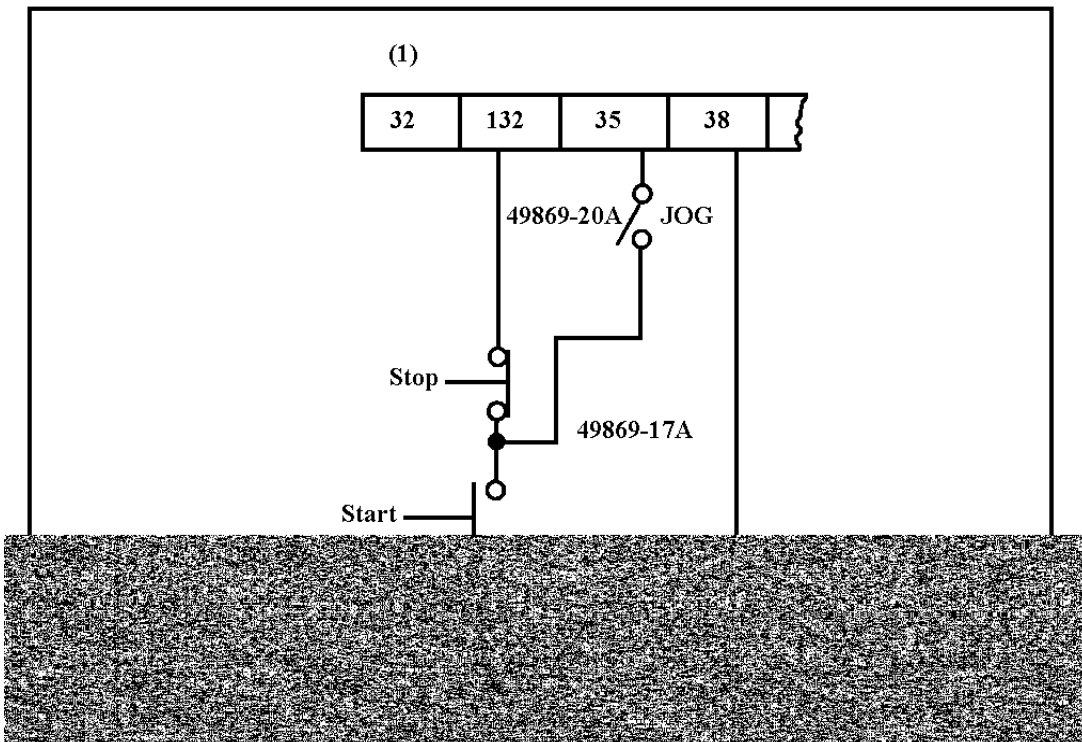

Figure 1.2 Start/Stop Circuit Connection.

### Wiring the Run/Jog Circuit

For drives without operator devices on the controller:

1. Run the Run/Jog wiring in conduit separate from the AC and DC power wiring
2. Use the appropriate tightening torque as listed in Table JB for wire connections to input and output terminals
3. Wire the Run/Jog switch as indicated in Figure JB.



### Wiring the Reference Signal Potentiometer (1365SAN, 1365PAN, 1365TAN)

For drives without operator devices on the controller:

1. Run all reference wiring in the same conduit as the Start/Stop control wiring separate from the AC and DC power wiring
2. Use the appropriate tightening torque as listed in Table JB for wire connections to input and output terminals
3. Use minimum #16 AWG cable that is twisted triple conductor with at least two twists per inch
4. Connect a 5K ohm, 0.25 watt pot having an insulated operator shaft and knob, such as available in Catalog 1365P or equivalent, as shown in Figure 14.

**ATTENTION:** Because the Reference Potentiometer is connected through the regulator to the Armature Power Circuit, its terminals are at line potential. Use a potentiometer that has plastic shaft to insulate the operator knob from the power circuit. Potentiometer must be rated to withstand HIPot tests at 2000 volts DC for one minute. Failure to observe this precaution could result in severe bodily injury or loss of life

### Wiring the Process Control and/or Automatic/Manual Devices (if required)

Controller catalog 1365PAN and 1365PAF have a high impedance input to interface with process signals. If both manual control (controller responds to a reference potentiometer) and process control (controller responds to an automatic signal) are desired, an Automatic/Manual switch is included in selected controller models (cat 1365PAF).

1. Use minimum #16 AWG unshielded cable that is twisted double conductor with at least two twists per inch
2. Use the appropriate tightening torque as listed in Table JB for wire connections to input and output terminals
3. Wire the process control signal to terminals TB4 ( 6+ ) and TB4 ( 5- ). See Figure 14.
4. Wire the process control buffered output TB2-26 to TB2-326. See Figure 14.
5. Wire the Automatic/Manual switch, if required, as shown in Figure 14.

### Wiring the DC Tachometer Speed Feedback Signal

**ATTENTION:** Because the Tachometer is connected through the regulator to the Armature Power Circuit, its terminals are at line potential. Disconnect all input power to the drive before servicing. Failure to observe this precaution could result in severe bodily injury or loss of life

All of the controllers, except catalog 1365DAF or one the user has configured for motor reversing, can utilize a DC tachometer as speed feedback. The tachometer must have a voltage range of 1.5 to 21.0 volts per 1000 RPM or 6.5 to 7.0 volts per 1000 RPM, maximum of 37 volts at maximum speed

1. Run the two tachometer signal leads in a separate conduit from the motor to the controller
2. Use minimum #16 AWG unshielded two wire cable that is twisted at least two twists per inch.

3. Use the appropriate tightening torque as listed in Table JB for wire connections to input and output terminals
4. Connect the DC tachometer so that the tach lead connected to terminal 519 is more positive than the tach lead connected to terminal 419 for the desired direction of rotation Refer to Figure 1.5.

**ATTENTION:** Reverse connection will cause the motor to run at maximum uncontrolled speed The DC tachometer must be connected so that the tach lead connected to terminal 519 is more positive than the negative tach lead connected to terminal 419 for the desired direction of rotation Failure to observe this precaution could result in bodily injury

5. An isolation transformer must be used between the AC power source and the controller to isolate the controller from the AC power source ground Each such controller must have it's own isolation transformer

**IMPORTANT:** Any 1365 controller used in a motor reversing application cannot employ a DC tachometer speed feedback

**NOTE:** A DC tachometer used as a speed feedback signal for one controller cannot be used as the speed reference signal for another controller.

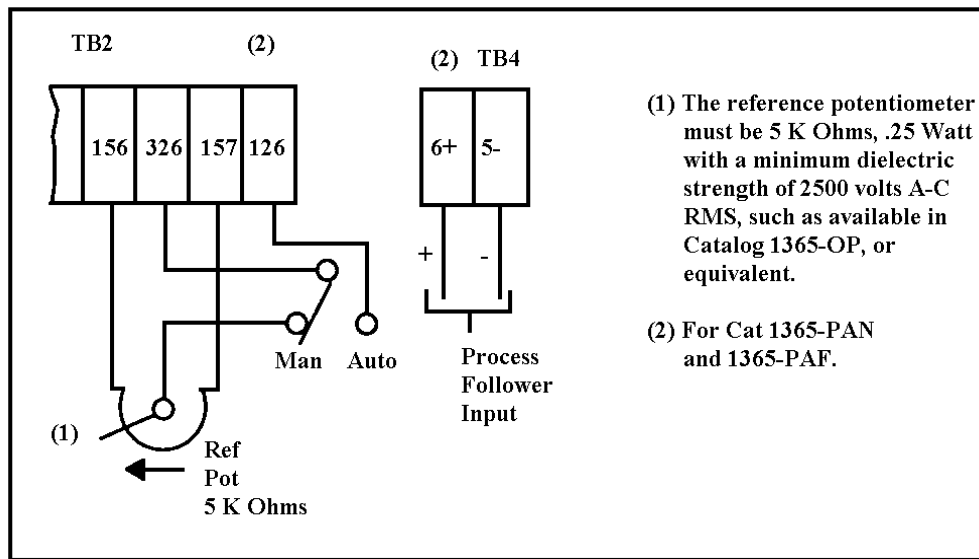

Figure 1.4 Reference Signal Connection

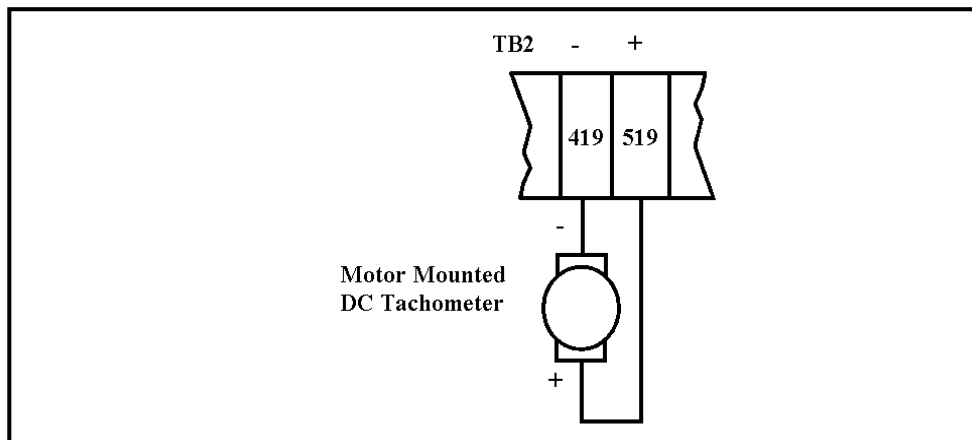
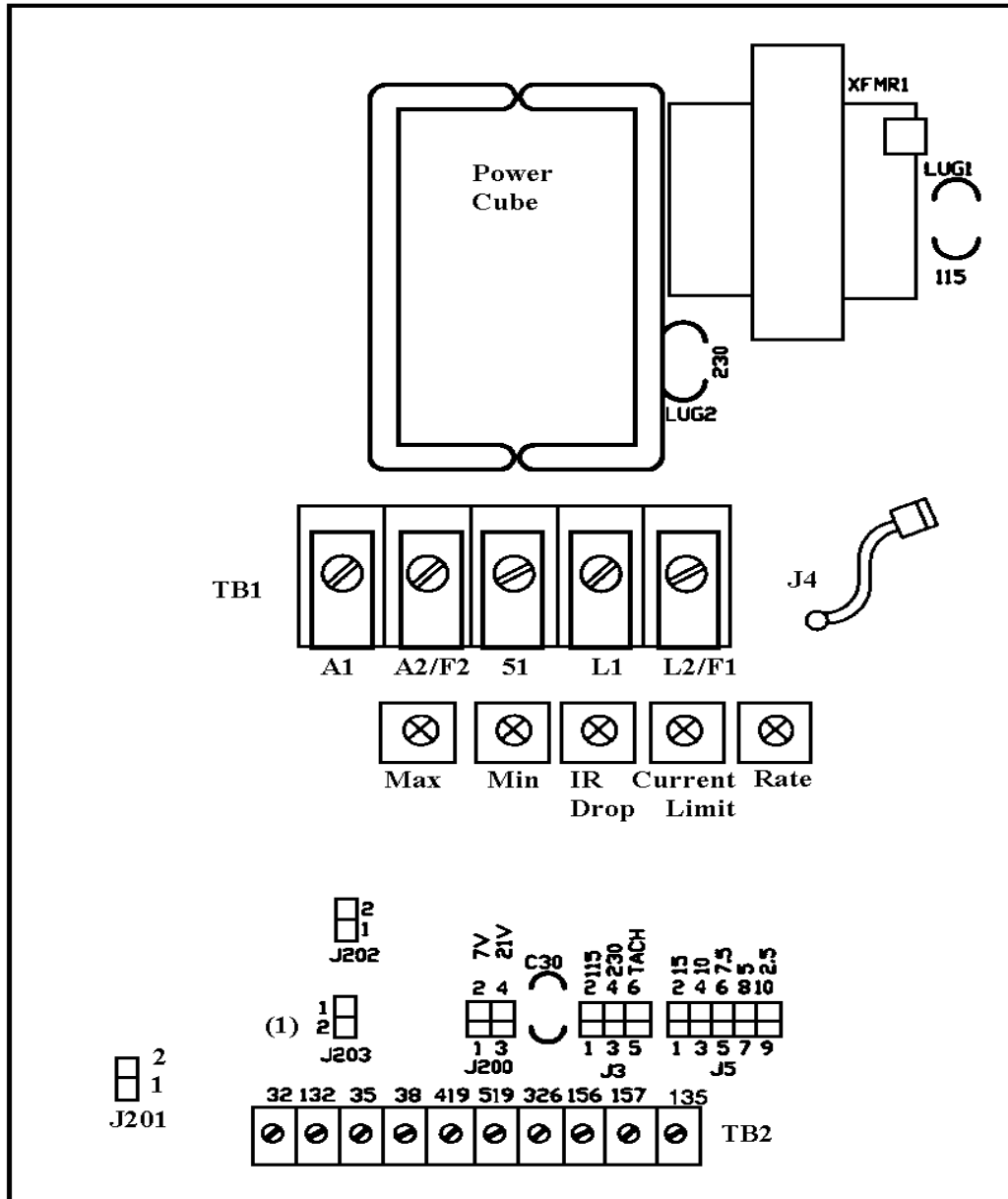
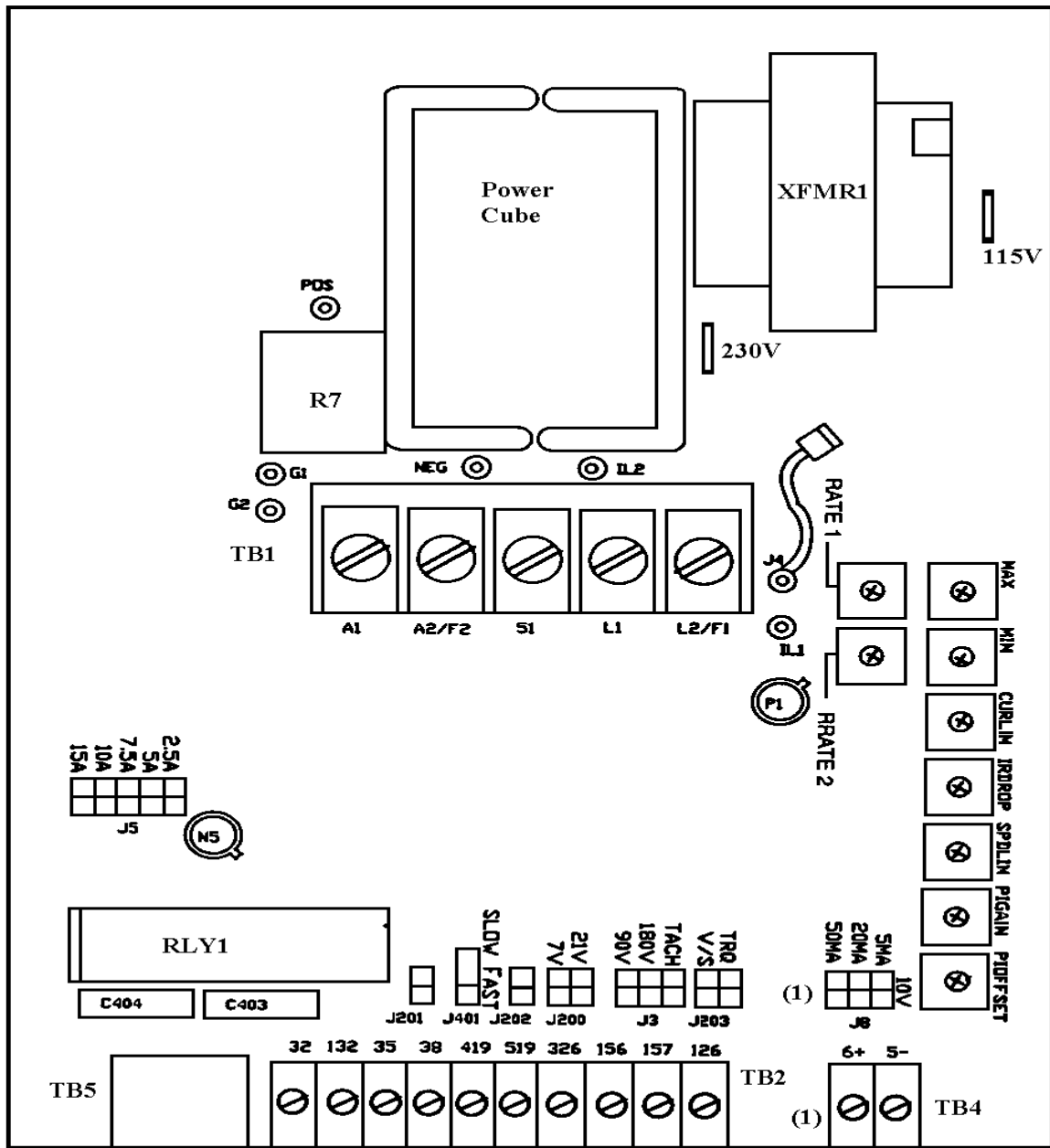

Figure 1.5 DC Tachometer Connection



(1) Do not use

Figure 1.6 Controller Terminal Board Locations ( Catalog 1365-SAN, 1365-SAF, and 1365-DAF).



(1) Functional on 1336-TAN and 1365-TAF only.

Figure 1.7 Controller Terminal Board Locations for Catalog 1365-TAN, 1365-PAF, and 1365-TAF.