

1365 Troubleshooting Guide

ATTENTION: Only qualified electrical personnel familiar with the construction and operation of this equipment and the hazards involved should install, adjust, and/or service this equipment. Read and understand this manual in its entirety before proceeding. Failure to observe this precaution could result in severe bodily injury or loss of life.

Should you encounter any difficulty with the operation of your Bulletin 1365 controller, review Table 1.A before performing any troubleshooting on the drive. The 1365 controller contains all regulator circuitry on one printed circuit board and all power conversion components (thyristors and diodes) in one power cube. If you determine that there has been a malfunction in either of these, replace the drive.

ATTENTION: Servicing energized industrial control equipment can be hazardous. Electrical shock, burns, or unintentional actuation of controlled industrial equipment may cause death or serious injury. Follow the safety related practices of NFPA 70E, Electrical Safety for Employee Workplaces, when working on or near energized equipment. Do not work alone on energized equipment.

Table 1.A Troubleshooting.

Indication	Possible Cause	Corrective Action
Controller incoming line fuse blows when power is applied to the controller.	Improper incoming AC line wiring or an inadvertent ground in the branch circuit or within the controller enclosure.	Check all incoming AC wires and terminations to and within the controller. Correct any wiring problems and remove any grounds. Replace blown fuse.
	Shorted SCR or malfunction in regulator.	Replace entire controller.
Controller incoming line fuse blows when Start command is given	Motor armature shorted or grounded.	Repair or replace motor. Replace blown fuse.
	Shorted SCR or malfunction in regulator	Replace entire controller.
	Loose or corroded connection or, incorrect or grounded wiring.	Check that all connections and wiring between the line, controller and motor are correct. Replace blown fuse.
	Sudden, severe application of overload to the motor.	Investigate driven equipment for possible cause and correct. Replace blown fuse.
	Circuit board malfunction.	Replace entire controller.
Motor does not rotate.	Faulty, incorrect or grounded wiring.	Check all external wires and terminations at the controller. Check all wiring within the motor conduit box. Correct wiring.
	Incoming line fuse blown and/or upstream protection devices open.	Investigate upstream equipment for possible cause and correct. Replace blown fuse.
	Open or malfunctioning manual speed or torque potentiometer.	Check all speed or torque pot wiring and the operation of speed or torque potentiometer. Correct.
	With Process Control models; faulty, misconnected or miscalibrated reference signal.	Check automatic reference signal for presence and value. Check for proper polarity. Check jumper for proper calibration. Correct as necessary.
	Start/Stop or Forward/Off/Reverse switch malfunctioning or in the incorrect position.	Investigate and/or replace switch as necessary.
	Motor thermostat open. Open on 32 and 132.	Check for continuity with ohmmeter. Let motor cool if found to be open.

Motor does not rotate. (Continued)	Open circuit between terminals 132 and 35. Either a jumper or normally closed remote stop device must be connected between these two terminals in order for the drive to operate.	Repair switch or insert jumper as required.
	Current feedback jumper set lower than applied motor horsepower.	Recheck and reset as necessary.
Drive will not go to zero speed or torque.	ATTENTION : Do not depend on the minimum position of the speed or torque setting pot to stop the motor. In the minimum position, the controller and motor are still energized. Noise, improper wiring, power line disturbances, malfunctioning components, or mechanical binding may cause the drive to restart unexpectedly. Failure to observe this precaution could result in bodily injury.	Follow the instructions provided in this manual to configure the drive for zero speed (J201: Minimum Speed Disable).
	Controller faulty.	Replace entire controller.
Motor does not reach top speed or deliver rated torque.	Low line voltage.	Check for rated line voltage and correct if not within 10% of the input voltage rating.
	With Process Control models, improperly set maximum speed pots.	Reset maximum speed pots.
	With Process Control models, reference signal producing less than expected maximum value.	Adjust source of automatic reference signal or proper output signal range.
	Overload.	Check for cause of overload and correct.
	Improper position jumper.	Check and reconnect jumper(s) as necessary: <ul style="list-style-type: none"> • J200: Tach Scaling Jumper • J3: Controller Output Current Jumper
	Faulty circuit board.	Replace entire controller.
Unstable speed or poor regulation when applied as an armature voltage	Incorrectly set IR drop compensation pot.	Readjust IR drop compensation pot. Check tachometer.
	Faulty circuit board.	Replace entire controller.
Incorrect speed with tachometer feedback.	Improper feedback selection at J3.	Check J3 for proper feedback selection and reposition as required.
Motor runs at maximum uncontrolled speed with tachometer feedback.	DC tachometer polarity not correct for given direction of motor rotation, 419 negative with respect to 519.	Verify DC tachometer polarity and lead connection.
	Open field for voltage Regulators only.	Measure motor field resistance from drive and connect the voltage field as required.
	No DC tachometer output signal.	Verify tachometer voltage. Verify tachometer coupling.
Motor speed unstable with changing load. (Tach Feedback only)	IR drop compensation pot not set at zero (CCW).	Set IR drop compensation pot to zero (CCW).

- **Spare Parts:** The following spare parts are available:
1365-OP Kit includes: - Speed Pot (P/N 608870-91r)
- Start/Stop Switch (P/N 49869-17a) - Run Jog or Auto/Manual switch (P/N 49869-20a)

Fuse Kit For open chassis: 1365-Fu 1 For NEMA 4/12: 1365-Fu 2

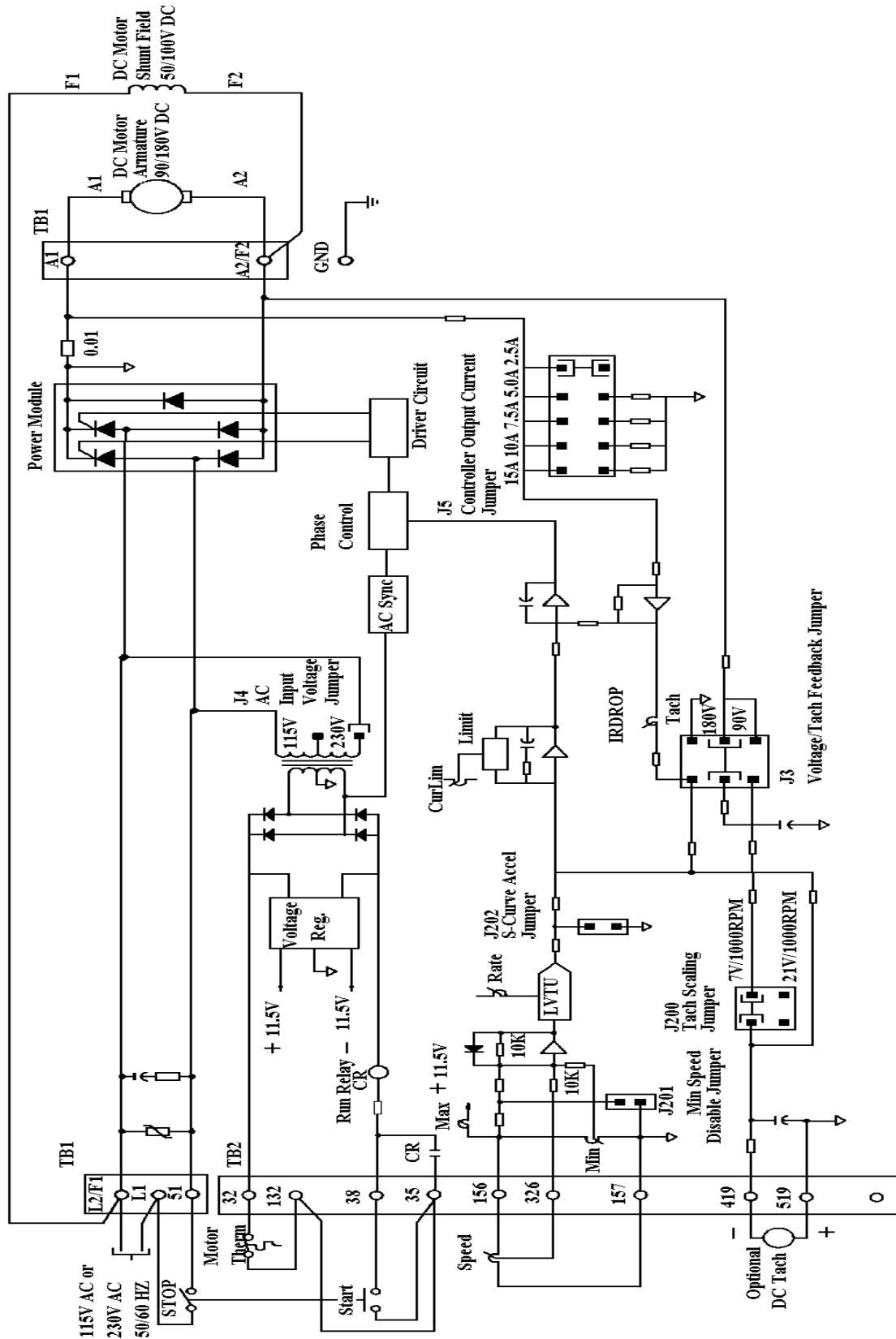

Figure 1.1 Wiring Diagram (Cat. Num. 1365-SAN/SAF/DAF).

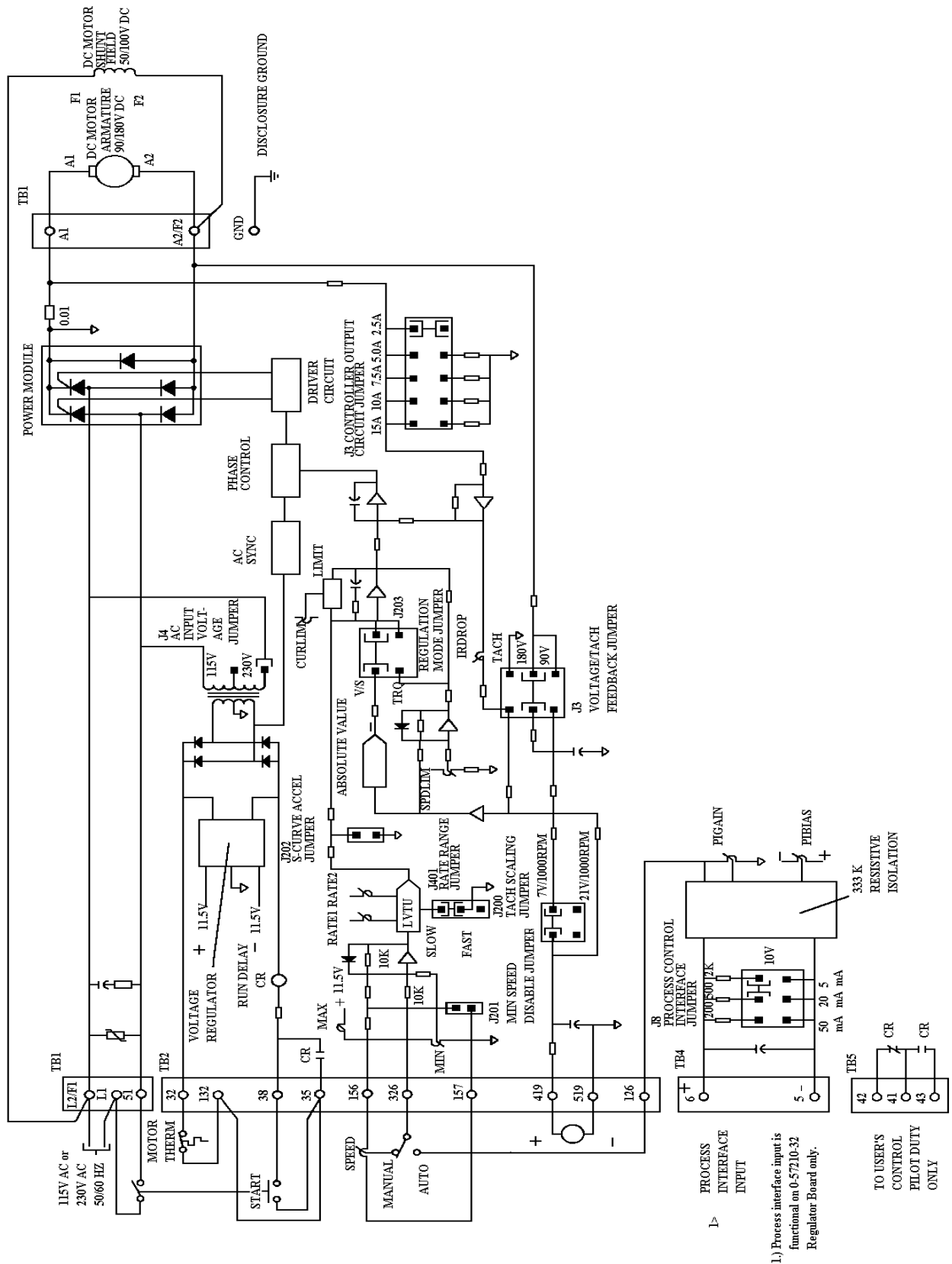

Figure 1.2 Wiring Diagram (Cat Num 1365-TAN/TAF/PAN/PAF).

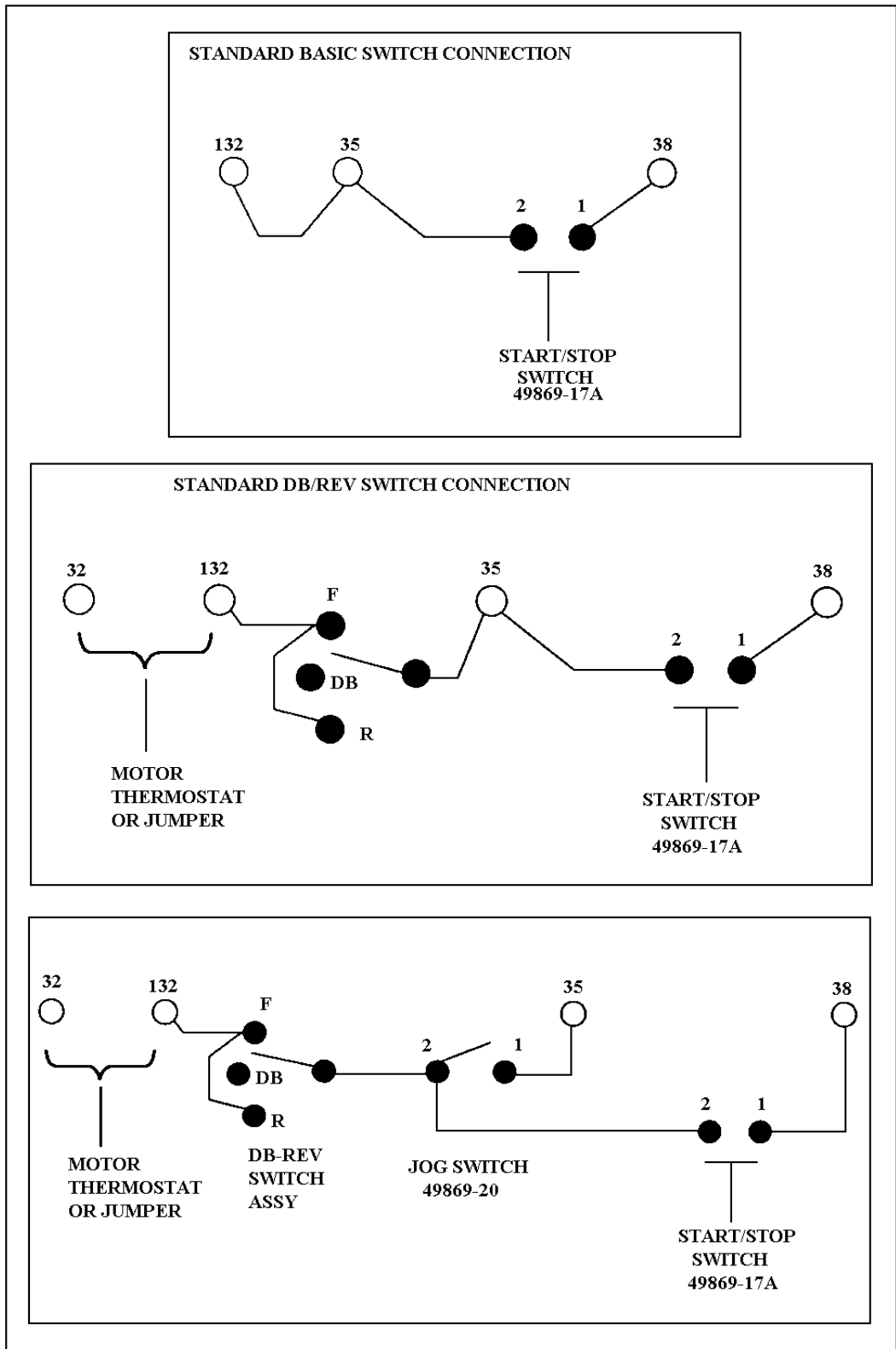

Figure 1.3 Switch configurations.

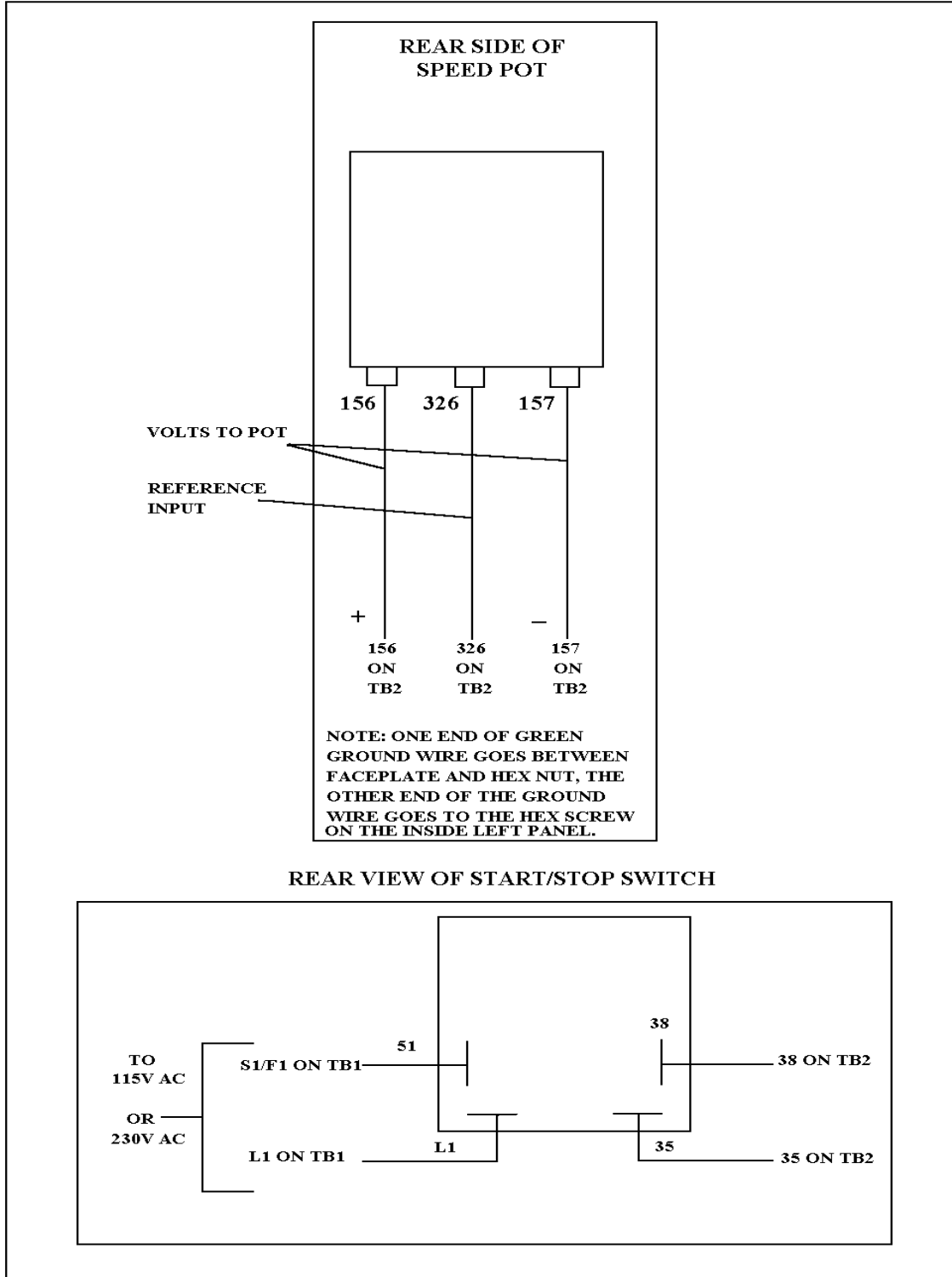

Figure 1.5 Operator Device Interconnections.
(Continued)