

1313 Connection/Troubleshooting Guide

1-5 HP • Single Phase • Full Wave • 120, 230 Volts • 60 Hz • Series A & C

IMPORTANT: In accordance with Allen-Bradley Terms and Conditions of Sale, this equipment is warranted to be free of defects in material and workmanship. Improper installation, incorrect wiring, or substitution of incorrect fuses will void this warranty. To be sure of receiving the best possible service, follow these installation and start-up instructions carefully.

DESCRIPTION

The Bulletin 1313 single phase full wave regulated speed drive system includes a DC motor, a drive controller, and an operator's control station. The system permits adjustment of motor output speed and regulates that speed as the motor load may vary. It was tested thoroughly before shipment to provide easy startup and satisfactory operation.

UNPACKING AND INSPECTION

After unpacking, check the material received against the Bill of Lading to insure that the nameplate description of each item agrees with the material ordered. Inspect the controller, motor, and control station for physical damage such as dents or broken wires. If damage is found, a claim should be filed immediately with the carrier. Also notify the Allen - Bradley distributor or Sales Office from which the equipment was ordered. Remove any packing material, wedges, or braces from within the drive controller. Operate contactors and relays by hand to assure that they operate freely. If any part of the equipment will not be installed as soon as it is unpacked, it should be stored in a clean dry place. Temperatures must be within 15°F and 165°F in order to prevent possible damage to semi-conductor components of the controller.

INSTALLATION

The National Electric Code and local codes will govern the installation and wiring of this equipment. A fused disconnect switch in the input circuit to the controller is recommended. Connections should be made in accordance with the wiring diagram furnished with the drive and supplemented in this instruction sheet. Since most start-up difficulties are the result of incorrect wiring, every precaution should be taken to assure that the wiring is as shown on the diagram.

Controller - The drive controller should be mounted securely in an upright position on a flat, vertical surface. Allow at least four inches of clearance on all sides of the enclosure for ventilation. Knockouts are provided at the top and bottom of the enclosure. Connections are made to the terminal strip at the bottom of the controller. The controller should not be subjected to shock, excessive vibration, moisture, dust, corrosive vapors, or excessive heat. Ventilating openings must not be obstructed. The maximum ambient temperature should not exceed 40° C (104° F) .

Motor - Careful attention to proper alignment and rigid support of the motor will avoid rough operation and early failure of motor bearings. If a belt or chain drive is used, excessive tension must be avoided to prevent unusual wear on the bearings. Consult the manufacturer's instructions, packed with the motor, for more detailed installation and maintenance procedures. Before the motor is connected, the shaft should be turned by hand to assure that it turns freely and that no obstruction is present. The brushes should be inspected to see that they are seated properly on the commutator. Connect the armature leads A1, A2, and field leads F+, F- as indicated on the wiring diagram.

Control Station - Mount the control station in any convenient location where it will be protected from mechanical damage. For best performance, the wires from the speed control potentiometer should be run thru separate conduit or otherwise isolated from the AC control wires. This will minimize noise pick-up and possible misfiring of the controller. If the control station will be a long distance (100 feet or more) from the controller, shielded cable and/or lower resistance wire may be required.

GROUNDING

To ground the motor armature or field circuit, an isolation transformer must be connected at the AC input circuit of the controller. The armature and field circuits must not be grounded at the same time. An isolation transformer can also be used when 230V AC power is not available or when it is desired to minimize line voltage transients.

OPERATING SPECIFICATIONS

The drive controller and motor are designed to operate under the following conditions and with the following performance characteristics:

1. Voltage: 230V + 10%, -5%; single phase; 60 Hz
2. Maximum Operating Ambient Temperature: 40°C (104 F).
3. Speed Deviation (Regulation): Under conditions of constant line voltage and constant temperature, the total speed deviation of the motor with a load change from 10% of full load to 100% will not exceed 1% of the rated motor base speed with tachometer feedback and 2% with armature feedback. This speed regulation will be obtained at any speed between base speed and 1/30 of base speed. For example, a motor having a base speed of 1750 RPM will not experience a speed deviation of more than 17.5 RPM under this load change with tachometer feedback and 35 RPM with armature feedback . The speed deviation is affected by ambient temperature and line voltage changes. A change in ambient temperature from 25°C to 40°C could produce a speed change as great as 6% if the line voltage is held constant. Similarly, a variation in line voltage of 10% could produce a speed change of 6% if the temperature is held constant.
4. Maximum Permissible Continuous Torque: The actual load that can be drawn from the motor or the duty cycle which it can sustain depends on the motor frame and enclosure. If a motor is to be operated at greatly reduced speed for long periods of time, it may be necessary to derate the motor in accordance with the table below.

| Percent Base Speed | Percent Rated Torque | |
|--------------------|----------------------|------|
| | Drip-Proof | TENV |
| 50 | 100 | 100 |
| 40 | 92 | 100 |
| 25 | 80 | 100 |
| 6 | 65 | 100 |

INITIAL START-UP PROCEDURE

After installation has been completed, follow this initial start-up procedure:

1. Set the Speed Control - The speed control potentiometer in the operator's control station should be set at the minimum speed position, fully CCW.
2. Close the Power Disconnect - This will apply line voltage to the controller, energizing the DC motor field.

WARNING: Do not touch the heat sinks or other conducting parts of the controller. They are energized and should be considered "Hot".

3. Measure the Field Voltage - With 230V AC applied to the controller, the DC motor field voltage should be approximately 105V from terminal F+ to F- 100V with 100V field or 205V from terminal F+ to F- 200V with 200V field. If field voltage is not present or is not within 10% of the correct value, refer to the troubleshooting section.
4. Press the Start Button - Pressing the control station Start button should pick up the motor contactor of the controller, closing the armature circuit and causing the motor shaft to turn slowly clockwise as viewed from the shaft end. (If CCW rotation is desired, armature leads A1 and A2 must be interchanged). If the shaft does not rotate, slowly increase the speed control setting to about one quarter of its rotation.
5. Increase Speed Setting - The motor should accelerate as the speed control potentiometer is turned clockwise, reaching approximately rated speed when the control is fully turned. If the motor does not respond to the control potentiometer or goes to full speed with no control, stop the drive, open the disconnect switch, and refer to the trouble-shooting section.

6. Press the Stop Button - When the control station Stop button is pressed, the motor contactor should open and the motor should coast to a stop within a time determined by the inertia of the load. If the controller is equipped with dynamic braking, the motor will stop rapidly, the inertial energy being dissipated in the braking resistor.

ADJUSTMENT

The five adjustment potentiometers on the cover of the swing-out panel have been set at the factory and may require minor adjustment unless operating conditions indicate otherwise. The adjustment potentiometers are for the following functions:

Minimum Speed - This adjustment determines the speed of the motor with the control station speed setting potentiometer at its minimum, fully CCW setting. This minimum speed can be set between standstill and approximately 10% of base speed. With the minimum speed adjustment set low, it may be necessary to turn up the control station speed setting potentiometer slightly before the motor shaft begins to rotate.

Maximum Speed - This adjustment determines the speed of the motor with the control station speed setting potentiometer at its maximum, fully CCW setting. This maximum speed can be set between approximately 80% to 120% of base speed.

CAUTION: If the incoming line voltage is high, it is possible to operate the motor at a considerable overspeed if the maximum speed adjustment is set too high.

Acceleration Time - The acceleration of the motor when starting and when increasing the setting of the control station speed setting potentiometer while the motor is running is influenced by a time-rate acceleration circuit. The adjustment potentiometer permits the motor to accelerate over a range of approximately 2 1/2 to 10 seconds. This provides smooth acceleration, adaptable to the needs of the driven machine.

NOTE: The IR compensation potentiometer is not used when the drive is equipped with the tachometer feedback option. It should be set at its full CCW position.

IR Compensation - This feature is incorporated to compensate for the drop in speed that a motor usually exhibits when its load is increased. Good regulation of motor speed is provided without the use of tachometers. In most cases, the factory setting of the IR compensation potentiometer will provide good operation over the entire motor speed range. If it is desired to improve the speed regulation at a given operating speed, it will be necessary to load and unload the machine at that speed and read the motor speed with a hand tachometer or other independent means. If the IR compensation setting is too high, a motor speed rising characteristic may result, which can lead to instability or oscillation in the motor speed. If such "hunting" is observed, reduce the IR compensation setting (turn CCW) until the oscillation disappears.

Current Limit - The current limit circuit of the controller senses the armature current so that when the average value reaches a set amount, the voltage applied to the motor is reduced to prevent additional current from being drawn regardless of the torque load applied to the motor shaft. Under these conditions, the motor will stall, which protects the motor and machine from extremely high torque which otherwise might develop, and also protects the controller and the SCR from burnout. This feature not only protects against excessive load peaks, but also over-rides the acceleration circuit to eliminate excess torque requirements when accelerating heavy loads. The current limit adjustment range is approximately 80% to 150% of motor full load current, factory-set at 150%. If it becomes necessary to adjust the current limit, follow this current measuring procedure:

1. Lock the motor shaft.
2. Connect a DC ammeter of appropriate range in the armature circuit.
3. Set the control station speed setting potentiometer and the current limit potentiometer at minimum.
4. Start the motor and observe the armature current as the control station potentiometer setting is slowly increased. After the setting is increased slightly, the armature current should stabilize at the current limit value. The current limit potentiometer can then be adjusted to the desired value.

CAUTION: Measuring the armature current should be done quickly to avoid excessive localized heating at the motor brushes and commutator. After setting the current limit, be sure to remove blocking and reconnect the armature leads.

If the motor shaft cannot be locked, the current limit value can be judged by observing the armature current when the motor is accelerated in the shortest acceleration time possible.

OPTIONAL FEATURES

The below listed optional features, except for dynamic braking and locking potentiometers are indicated on the wiring diagrams on the following pages.

Dynamic Braking - A resistor is provided in the controller and is connected across the armature of the DC motor by a normally closed contact of the motor contactor in order to bring the motor to a quicker stop when the Stop button is pressed. Under these conditions, the motor acts as a generator and drives current thru the dynamic braking resistor providing a counter-torque that stops the motor and load. The rate at which the motor stops depends upon the friction and inertia of the load to which it is attached. Dynamic braking is an option on non-reversing drives and is provided as standard on reversing drives.

Reversing - When it is desired to operate the motor in either direction, its rotation can be reversed by the operation of a reversing contactor in the controller. The connection of the controller output voltage to the motor armature is selected for whichever direction of rotation is desired. An operator's station with a Forward and Reverse push button or selector switch must be used. An anti-plug type relay is provided to prevent the application of voltage to the motor until it has come nearly to a standstill from either direction of rotation.

Jog at Set Speed - When it is desired to jog or inch the motor, a control station with a Jog-Run selector switch can be used. Placing the Jog-Run selector switch in the Jog position opens the seal-in circuit to the motor contactor. Thus the motor will only run when the Start push button is pressed and held down. The speed at which the motor will run will be controlled by the setting of the remote speed control potentiometer.

Jog at Independently Set - Speed - In this case, the controller includes an internally mounted jog speed potentiometer, which allows the jogging speed to be set independently of the setting of the control station speed potentiometer.

Tachometer Feedback - When this option is used all connections to the drive should be made, with care, as indicated on the wiring diagram.

Adjustments to the tachometer feedback card can be made to improve speed regulation. The null potentiometer (17R) is set so that voltage out of the operational amplifier (2-OP) is zero volts DC. This is measured between the cathode terminal of 37D and line 107. The bias potentiometer (47R) located on the firing circuit card, is adjusted so that the motor armature does not rotate with the flow of armature current.

Follower Input - The follower input option allows inputs of 0-5 mA DC, 0-15 mA DC, 0-10 VDC, 0-50 VDC or 0-150 VDC to be used instead of the speed potentiometer. Consult the factory for follower input with tachometer feedback option.

Locking Potentiometers - When any of the potentiometers mounted on the hinged swing panel are supplied with the locking option, the panel must be swung open to make adjustments.

WIRING DIAGRAMS - (See Applicable Codes and Laws)

| Diagram Description | Number |
|---|--------|
| Basic Connections | 1 |
| Non - Reversing | |
| Start - Stop Push Buttons | 2 |
| Jog Run Selector Switch, Start - Stop Push Buttons | 3 |
| Jog Run Selector Switch, Start - Stop Push Buttons (for Independent Jog) | 4 |
| Reversing | |
| Forward - Reverse - Stop Push Buttons | 5 |
| Jog - Run Selector Switch, Forward - Reverse - Stop Push Buttons | 6 |
| Jog - Run Selector Switch, Forward - Reverse - Stop Push Buttons (for Independent Jog) | 7 |
| Forward - Reverse Selector Switch, Start - Stop Push Buttons | 8 |
| Jog - Run Selector Switch, Forward - Reverse Selector Switch, Start - Stop Push Buttons | 9 |
| Jog - Run Selector Switch, Forward - Reverse Selector Switch, Start - Stop Push Buttons (for Independent Jog) | 10 |

Controller Terminals

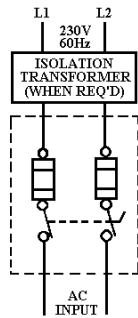

Controller Terminals

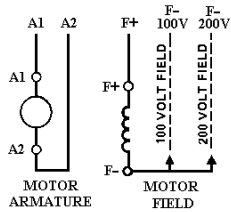

Motor armature connections illustrated above are for clockwise rotation when viewed from the shaft end of the motor.

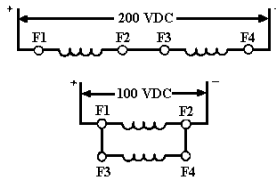

Typical dual voltage motor field connections are shown above. Consult the motor manufacturer's instructions for correct connections.

Controller Terminals

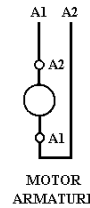

Motor armature connections illustrated are for counter-clockwise rotation when viewed from the shaft end of the motor.

Controller Terminals

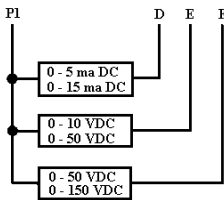

When a drive is equipped with the follower input option, the speed potentiometer is not used.

Controller Terminals

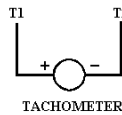

Tachometer connections are illustrated for clockwise motor rotation when viewed from the shaft end. Reverse the tachometer leads for counterclockwise rotation.

Consult factory for follower input with tachometer feedback option.

Controller Terminals

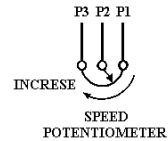

Connect speed potentiometer as illustrated, except as indicated otherwise in Diagram Nos. 4, 7 and 10.

Diagram No. 1

Controller Terminals

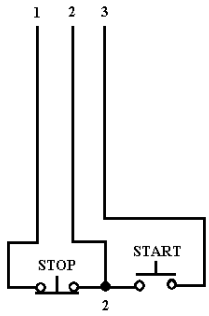

Diagram No. 2

Controller Terminals

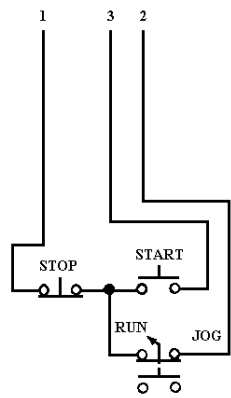

Diagram No. 3

Controller Terminals

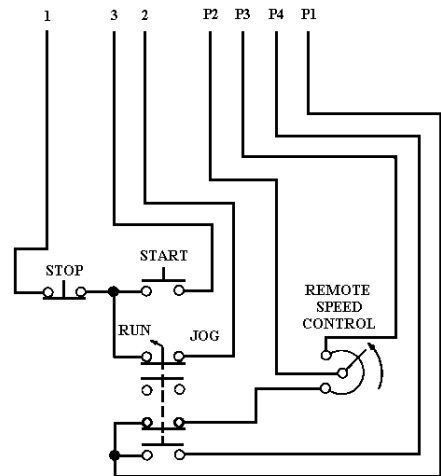

Diagram No. 4

Controller Terminals

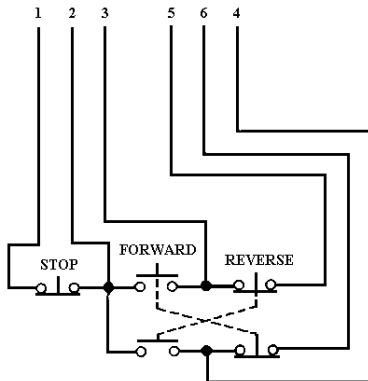

Diagram No. 5

Controller Terminals

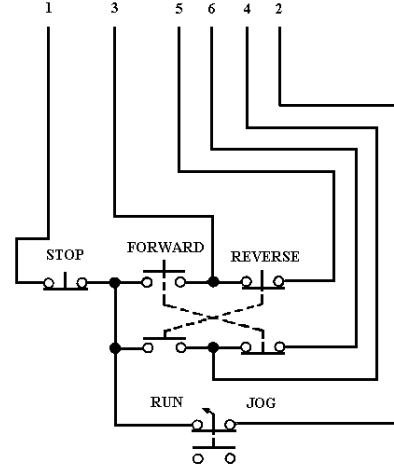

Diagram No. 6

Controller Terminals

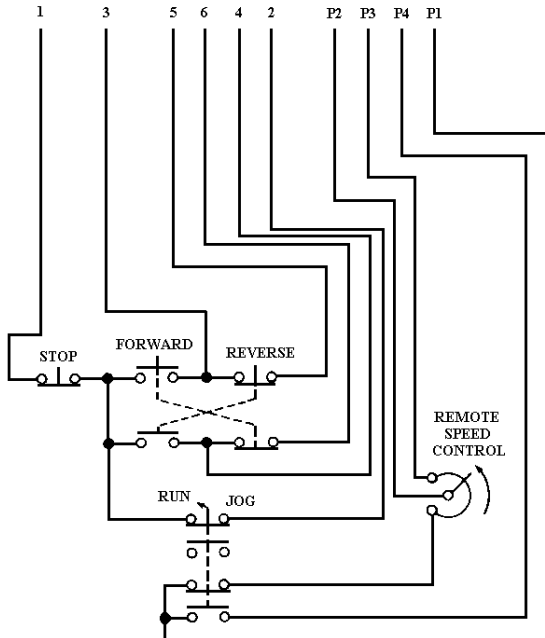

Diagram No. 7

Controller Terminals

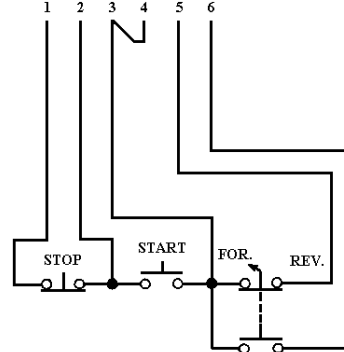

Diagram No. 8

Controller Terminals

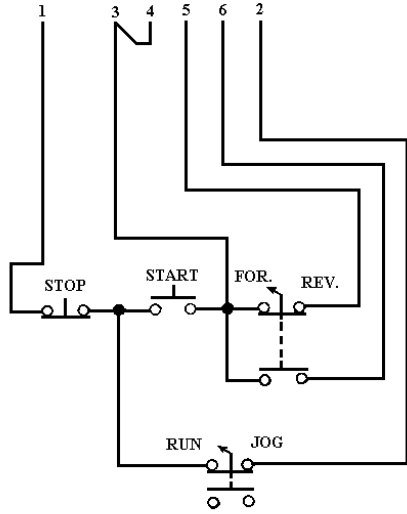

Diagram No. 9

Controller Terminals

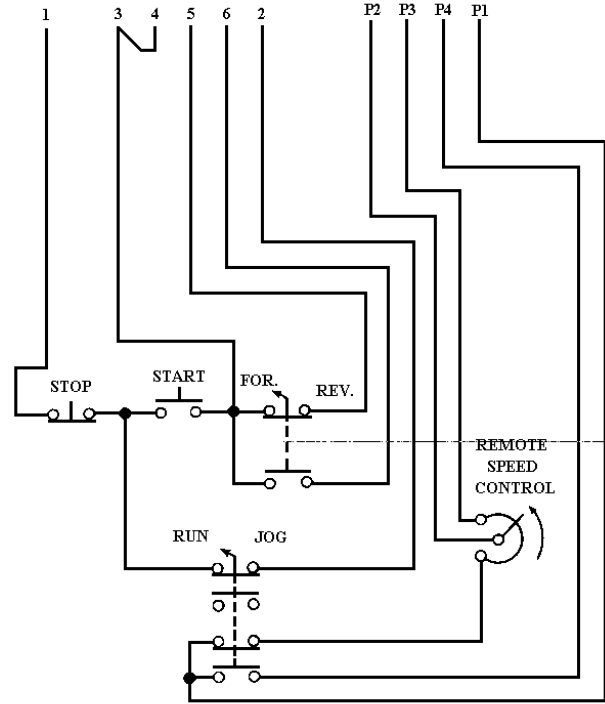
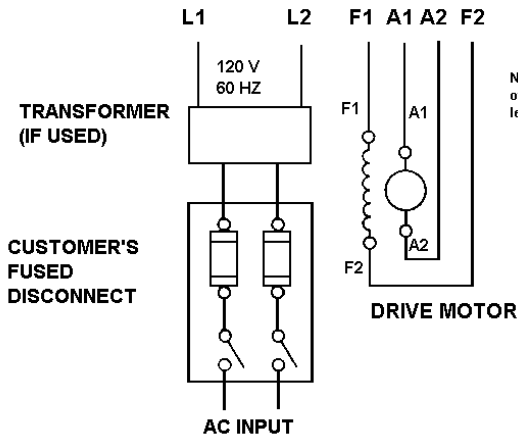

Diagram No. 10

Bulletin 1313

WIRING DIAGRAMS

CONTROLLER TERMINALS



| CONTROL STATIONS | |
|---|--------------------------|
| DESCRIPTION | CATALOG NO. |
| SPEED POTENTIOMETER START-STOP BUTTONS | 800S-2SXM8 8005-3TW70 |
| SPEED POTENTIOMETER FOR-REV-STOP BUTTONS | 800T-4TW1 |
| SPEED POTENTIOMETER JOG-RUN SELEC. SWITCH START-STOP BUTTONS | 800T-4TW72 |
| SPEED POTENTIOMETER FOR-REV SELEC. SWITCH START-STOP BUTTONS | 800T-4TW74 |
| SPEED POTENTIOMETER JOG-RUN SELEC. SWITCH FOR-REV-STOP BUTTONS | 800T-5TW73 |
| SPEED POTENTIOMETER JOG-RUN SELEC. SWITCH FOR-REV SELEC. SWITCH START-STOP BUTTONS | 800T-5TW75 |

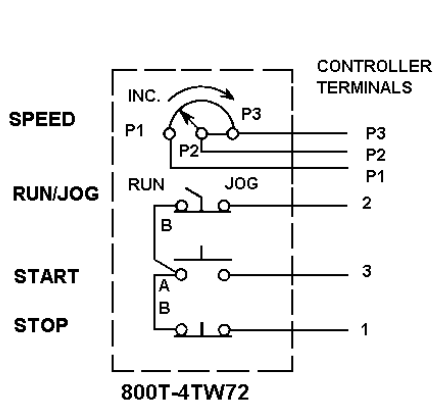

800T-4TW72

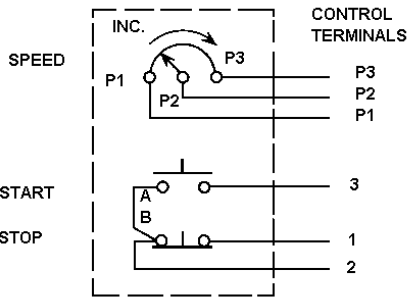

800S-2SXM8, 800T-3TW70

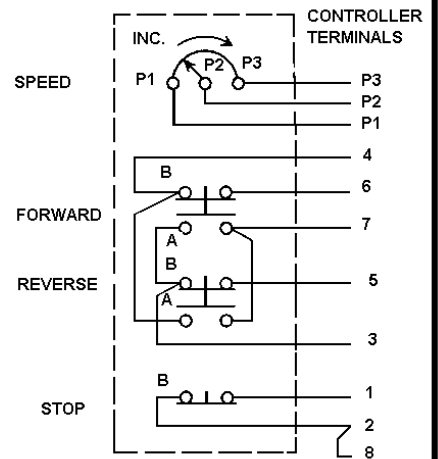

800T-4TW71

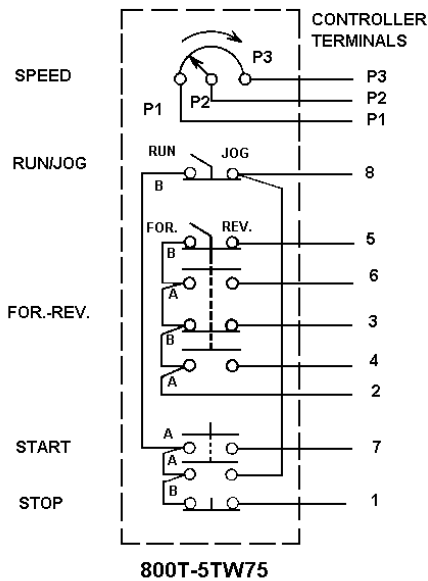

800T-5TW75

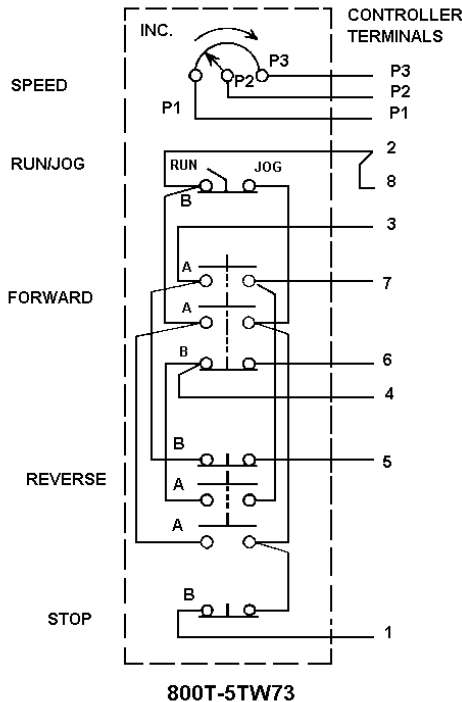

800T-5TW73

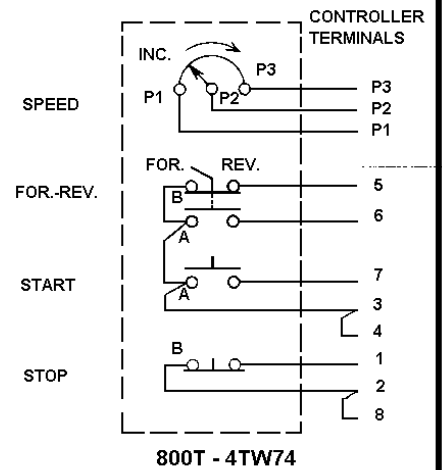

800T-4TW74

POWER REQUIREMENTS FOR 1313 C

| HP of Drive | AC Line Input 230V 60 Hz Single Phase | DC Drive Motor 0 - 180V Armature 100V or 200V Field | | Recommended Heater Element |
|-------------------|---|---|-----------------------------------|--------------------------------------|
| | Approx. Amperes at Full Motor Load | Approx. Full Load Armature Amps. | Approx. Field Amps. Max. | |
| 1 | 8 | 6 | 0.7 | N27 |
| 1 1/2 | 12 | 8.5 | 1.0 | N30 |
| 2 | 16 | 11 | 1.0 | N33 |
| 3 | 21 | 16 | 1.5 | N36 |
| 5 | 36 | 26 | 2.0 | N41 |

TROUBLESHOOTING FOR 1313 C

The Bulletin 1313 controller was thoroughly tested with a motor before shipment and was adjusted to operate well within published specifications. If careful installation has been made and the start-up instructions were followed, satisfactory operation should be secured with no further effort. NOTE: It is important to remember that more than 90% of start-up difficulties and operating malfunctions arise from incorrect wiring of the external circuits or application of the motor to a load for which it is not suited. The trouble-shooting guide is intended to assist in localizing difficulties if a malfunction should occur. If the difficulty is traced to one of the printed circuit cards, remove and replace with another. Printed circuit card repairs should be attempted only by competent personnel under suitable bench conditions. When a warranty failure is suspected involving the printed circuit card, please return the card to the company instead of attempting to repair it.

WARNING: When the swing-out panel on which the adjustment potentiometers are mounted is open, live current carrying parts are exposed. Take necessary precautions when troubleshooting.

VOLTAGE CHECK POINTS FOR 1313 C

| Description | Between Terminals | Reading |
|-----------------------------|--------------------------------|--|
| Line Voltage | L1, L2 | 230V AC, +10%, -5% |
| Control Voltage | 1, 11 | 230V AC, +10%, -5% |
| DC Motor Field | F+, F- 100V F+, F- 200V | 105V DC, approx. 205V DC, approx. |
| Dc Motor Armature | A1, A2 | 0 - 180V DC approx., as speed pot goes from 0 to full speed. A1 is normally positive for forward rotation. |
| Speed Pot Supply Voltage | P1, P3 | 10 V DC, P3 is positive. |
| Speed Pot Signal Voltage | P1, P2 | 0 - 10 V DC as pot goes from 0 to full speed. P2 is positive. |
| Transformer Secondary | Wires 20, 21, 107 | 48V Center tap |
| Firing Circuit Power Supply | Wires 107, 30 Wires 107, 45 | 15V DC, 30 is positive. 15V DC, 45 is negative. |

BULLETIN 1313 C TROUBLESHOOTING GUIDE

| Symptom or Malfunction | Possible Cause | Suggested Cure |
|--|--|---|
| 1. Blown Fuse(s) in customer fused disconnect. | <ol style="list-style-type: none"> 1. Short circuit or ground in wiring to the controller, operator's station or motor. 2. Short circuit within the controller, station, or motor. | <ol style="list-style-type: none"> 1. Check wiring. Remove fault. 2. Isolate controller, station and motor. Check for shorts and grounds; remove. |
| 2. Blown fuse in the drive controller. | <ol style="list-style-type: none"> 1. Short circuit in motor or wiring to motor, motor field, motor armature. 2. Short circuit in operator's station or wiring to station. 3. Short circuit or ground in controller, thyristors (1SCR, 2SCR), silicon rectifiers (1D, 2D, 3D), transient suppression network, line reactor (1L), thyrector on printed circuit card. | <ol style="list-style-type: none"> 1. Isolate motor. Remove fault. 2. Isolate station. Remove fault. 3. Replace faulted component or printed circuit card. |
| 3. Motor field voltage low or not present. | Line voltage not within limits of 230V AC +10% -5%, silicon rectifier (1D, 2D) open. field circuit wiring incorrect. | Correct line voltage. Replace and wire correctly. |
| 4. Contactor does not pick up when the "START" button is operated. | <ol style="list-style-type: none"> 1. Line voltage not within limits of 230V +10% -5%. Controller fuse blown. 2. Control station wiring incorrect. 3. Motor overload relay MOL tripped. 4. Line reactor, 1L, open circuited. 5. Contactor coil open circuited. | <ol style="list-style-type: none"> 1. Correct line voltage. Locate cause, repair, replace fuse with another of the same type and rating. 2. Correct wiring. 3. Correct cause of trip, reset. 4. Replace 1L. 5. Replace coil. |
| 5. Contactor picks up before "START" button is operated. | Faulty wiring to control station or faulty push-button. | Correct wiring, replace button. |
| 6. Motor will not run even though contactor is energized and picked up. | <ol style="list-style-type: none"> 1. Incorrect armature circuit wiring. 2. DC motor armature open circuited or brushes not seated on commutator. 3. Motor overload, heater element or current sensing element open circuited. 4. Firing circuit printed circuit card faulty. 5. Power supply printed circuit card faulty. | <ol style="list-style-type: none"> 1. Correct wiring to conform to wiring diagram. 2. Correct motor. 3. Replace open element. 4. Replace card. 5. Replace card. |
| 7. Motor will only run slowly, regardless of speed pot setting. | <ol style="list-style-type: none"> 1. Motor is running in current limit condition. 2. Operator's control station, speed pot wired incorrectly. | <ol style="list-style-type: none"> 1. See Item #11 2. Correct wiring. |
| 8. Motor runs only at top speed regardless of speed pot setting. | <ol style="list-style-type: none"> 1. Operator's control station, speed pot wired incorrectly. 2. Thyristors m(1SCR, 2SCR) shorted. | <ol style="list-style-type: none"> 1. Correct wiring. 2. Replace Thyristors. |
| 9. Motor will not develop rated torque at rated speed. | Motor is running in current limit condition. | See item #11. |
| 10. Motor speed regulation is poor; speed drops excessively with increased load. | <p>Controller is producing only half wave rectified voltage to motor armature.</p> <ol style="list-style-type: none"> 1. Silicon rectifiers 1D or 2D open. 2. Thyristors 1SCR or 2SCR open. | <ol style="list-style-type: none"> 1. Locate and replace. 2. Locate and replace. |
| 11. Motor operates continuously in current limit condition. | <ol style="list-style-type: none"> 1. Excessive load on motor. 2. Current limit pot set to low. | <ol style="list-style-type: none"> 1. Reduce load, continuous DC armature current when red with ammeter in series with armature should not exceed rated current |

| | | |
|--|--|---|
| | | stamped on motor nameplate. 2. Re-adjust |
|--|--|---|

BULLETIN 1313 C TROUBLESHOOTING GUIDE (Cont.)

| | | |
|--|---|--|
| <p>12. DC motor exhibits poor speed regulation.</p> <p>a) Greater than load change without tachometer feedback option.</p> <p>b) Greater than 1% for full load change with tachometer feedback option.</p> | <p>1. IR compensation pot too low (Should be set at full CCW position if drive is equipped with tachometer feedback option.)</p> <p>2. Current sensing element (CSE) damaged.</p> <p>3. Motor armature circuit wiring from controller to motor too small or leads too long.</p> <p>4. Firing circuit card faulty.</p> <p>5. Power supply card faulty.</p> <p>6. Tachometer card faulty (if applicable).</p> | <p>1. Re-adjust, turning clockwise a little at a time until suitable regulation is obtained.</p> <p>2. Replace.</p> <p>3. Replace with more generous wire size.</p> <p>4. Replace card.</p> <p>5. Replace card.</p> <p>6. Replace card (if applicable)</p> |
| <p>13. Motor speed unstable; tends to oscillate or "hunt"</p> | <p>IR compensation pot set too high.</p> | <p>Re-adjust - turning counterclockwise a little at a time until oscillation disappears. Turn IR compensation potentiometer fully CCW when drive is equipped with tachometer feedback option.</p> |

NOTE: A volt-ohmmeter having 20,000 ohms/volt DC and 5000 ohms/volt AC is recommended for trouble-shooting.

1313 A Troubleshooting Guide

It is important to remember that more than 90% of start-up difficulties and operating malfunctions arise from incorrect wiring of the external circuits or application of the motor to a load for which it is not suited. The troubleshooting guide below is intended to assist in localizing difficulties if a malfunction should occur. If the difficulty is traced to the printed circuit card, remove and replace with another. Printed circuit card repairs should be attempted only by competent personnel under suitable bench conditions. When a warranty failure is suspected involving the printed circuit card, please return the card to the company instead of attempting to repair it.

WARNING: When the enclosure cover is removed, live current carrying parts are exposed. Take necessary precautions when troubleshooting.

VOLTAGE CHECK POINTS FOR 1313 A

| Description | Between Terminals | Reading |
|--------------------------|-------------------|--|
| Line Voltage | L1, L2 | 120V AC, +10%, -5% |
| DC Motor Field | F1, F2 | 108V DC, +/- 10%. F1 is positive |
| Dc Motor Armature | A1, A2 | 0 - 90V DC approx., as speed pot goes from 0 to full CW setting. A1 is normally positive for forward rotation. |
| Speed Pot Supply Voltage | P1, P3 | 12V DC, P3 is positive. |
| Speed Pot Signal Voltage | P1, P2 | 0 - 12V DC as pot goes from 0 to full CW setting. P2 is positive. |

Troubleshooting Procedures for 1313 A

| Symptom or Malfunction | Possible Cause | Suggested Cure |
|---|---|---|
| 1. Blown Fuse in customer fused disconnect. | <ol style="list-style-type: none"> 1. Short circuit or ground in wiring to the controller, operator's station or motor. 2. Short circuit within the controller, station, or motor. | <ol style="list-style-type: none"> 1. Check wiring. Remove fault. 2. Isolate controller, station and motor. Check for shorts and grounds; remove. |
| 2. Blown fuse in the drive controller. | <ol style="list-style-type: none"> 1. Short circuit in motor or wiring to motor, motor field, motor armature. 2. Short circuit in operator's station or wiring to station. 3. Short circuit or ground in controller, thyristor (1SCR), silicon rectifiers (Encapsulated Bridge), transient suppression network, Transient Suppressor, thyrector on printed circuit card. | <ol style="list-style-type: none"> 1. Isolate motor. Remove fault. 2. Isolate station. Remove fault. 3. Replace faulted component or printed circuit card. |
| 3. Motor field voltage low or not present. | Line voltage not within limits of 120V AC +10% -5%, silicon rectifier (Encapsulated Bridge) shorted or open. Field circuit wiring incorrect. Blown fuse. | Correct line voltage. Replace and wire correctly. |
| 4. Contactor does not pick up when the "START" button is operated. | <ol style="list-style-type: none"> 1. Line voltage not within limits of 120V +10% -5%. Controller fuse blown. 2. Control station wiring incorrect. 3. Motor overload relay MOL tripped. 4. Contactor coil open circuited. | <ol style="list-style-type: none"> 1. Correct line voltage. Locate cause, repair, replace fuse with another of the same type and rating. 2. Correct wiring. 3. Correct cause of trip, reset. 4. Replace coil. |
| 5. Contactor picks up before "START" button is operated. | Faulty wiring to control station or faulty push-button. | Correct wiring, replace button. |
| 6. Motor will not run even though contactor is energized and picked up. | <ol style="list-style-type: none"> 1. Incorrect armature circuit wiring. 2. DC motor armature open circuited or brushes not seated on commutator. 3. Motor overload, heater element or current sensing element open circuited. 4. Printed circuit card faulty. | <ol style="list-style-type: none"> 1. Correct wiring to conform to wiring diagram. 2. Correct motor. 3. Replace open element. 4. Replace card. |
| 7. Motor will only run slowly, regardless of speed pot setting. | Operator's control station, speed pot wired incorrectly. | Correct wiring. |
| 8. Motor runs only at top speed regardless of speed pot setting. | <ol style="list-style-type: none"> 1. Operator's control station, speed pot wired incorrectly. 2. Thyristor (1SCR) shorted. | <ol style="list-style-type: none"> 1. Correct wiring. 2. Replace Thyristor. |
| 9. Motor will not develop rated torque at rated speed. | <ol style="list-style-type: none"> 1. Encapsulated Bridge defective. 2. IR compensation pot set too low. 3. Printed circuit card faulty. | <ol style="list-style-type: none"> 1. Locate and replace. 2. Re-adjust. Turn CW slowly until motor speed is constant. 3. Replace card. |
| 10. DC motor exhibits poor speed regulation (greater than 5% for full load change). | <ol style="list-style-type: none"> 1. IR compensation pot set too low. 2. Motor armature circuit wiring from controller to motor too small or leads too long. 3. Printed circuit card faulty. | <ol style="list-style-type: none"> 1. Re-adjust, turning CW a little at a time until suitable regulation is obtained. 2. Replace with more generous wire size. 3. Replace card. |
| 11. Motor speed unstable; tends to | IR compensation pot set too high. | Re-adjust, turning CCW a little at a |

| | | |
|----------------------|--|------------------------------------|
| oscillate or "hunt". | | time until oscillation disappears. |
|----------------------|--|------------------------------------|

NOTE: A volt-ohmmeter having 20,000 ohms/volt DC and 5000 ohms/volt AC is recommended for trouble-shooting.