

1331 CONNECTION GUIDE

The Power Terminal Block is a six position terminal block mounted on the lower left portion of the drive. All input and output power connections are marked.

The Bulletin 1331 does not provide protection against input power short circuits. Recommendations for branch short circuit protection are provided in Publication No.: 1331.5.0

This terminal is connected to earth ground or the ground of the building electrical system. The motor frame should also be connected to earth ground. Refer to the motor manufacturer's guidelines for specific details.

L1 L2 Connect these terminals to a branch circuit protected 10 AC input. Verify that the incoming power matches the voltage specified for your drive in Publication No.: 1331.5.0

M1/T1 M2/T2 M3/T3 Connect the motor leads to these terminals.

IMPORTANT

- 1) Verify that induction motor windings are properly connected and agree with the drive output voltage rating.
- 2) For multimotor operation the combined total of motor full load current must not exceed the continuous rated output current of the drive.
- 3) A ground terminal has been provided on the Bulletin 1331 that must be connected to earth ground or the ground of the building electrical system. The motor frame must also be connected to earth ground. Refer to the motor manufacturer's guidelines for specific details.
- 4) The maximum wire size the Power Terminal Block will accept is 12 AWG. Torque all terminal screws to 8KG-CM (7 IN-LBS).

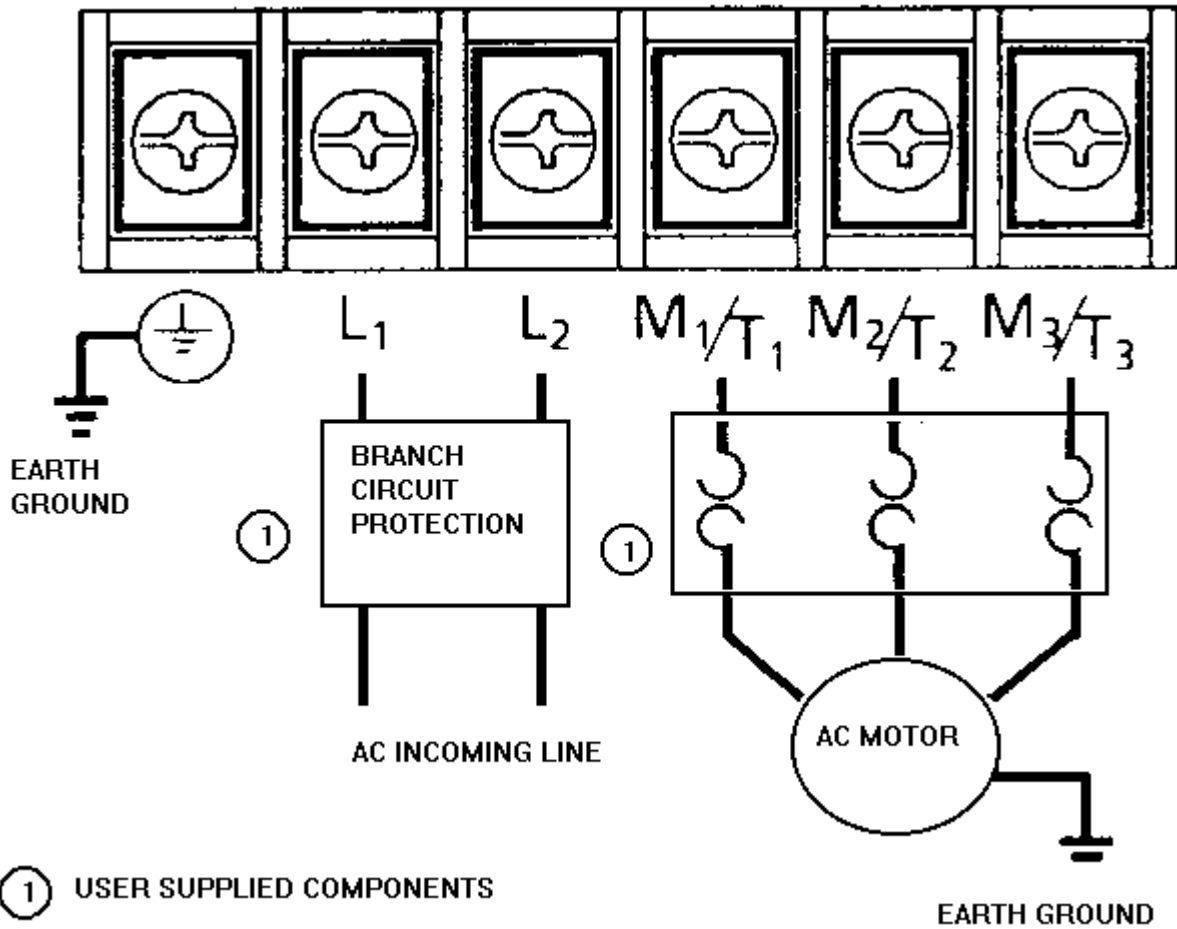

CONTROL TERMINAL BLOCK TB1

Control Terminal Block TB1 is an eleven position terminal block mounted on the lower right portion of the drive. All input and output connections are marked. An additional code has been added to indicate wire colors for the Local Control Panel--1W (white), 2R (red), 3O (orange), 5G (green), 6B (blue), and 7V (violet). The maximum wire size the Control Terminal Block will accept is 16 AWG. Torque all terminal screws to 5KG-CM (4.5 IN-LBS).

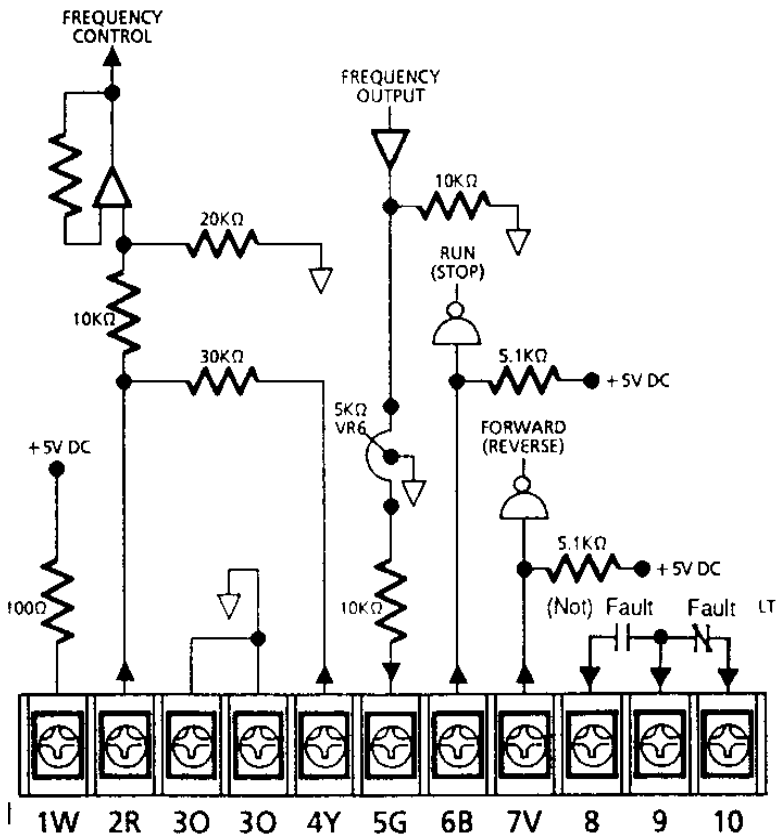

- 1W — Potentiometer High
- 2R — Potentiometer Wiper
- 3O — Logic Common
- 3O — Logic Common
- 4Y — 0-10V DC Input Input
- 5G — 0-1mA Frequency Output
- 6B — Run/Stop Input
- 7V — Forward Reverse Input
- 8 — Fault Signal Output
- 9 — Fault Signal Output
- 10 — Fault Signal Output

If the Local Control Panel is installed, the Bulletin 1331 is capable of operating without additional connections to TB1. If required, external operator elements may replace the Local Control Panel to provide remote control. Several additional control functions and status outputs are also available for customer use at TB1.

CONTROL TERMINAL BLOCK TB 1--SPEEDCONTROL

10K Ohm Potentiometer Control Input
-- 5V DC Internal Source --

0-10V DC Control Input
-- 40K Ohm Drive Impedance

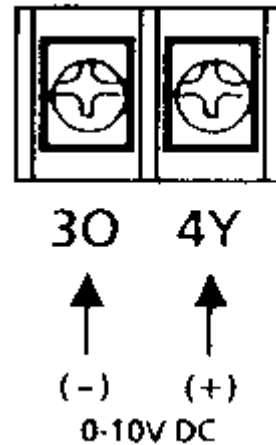
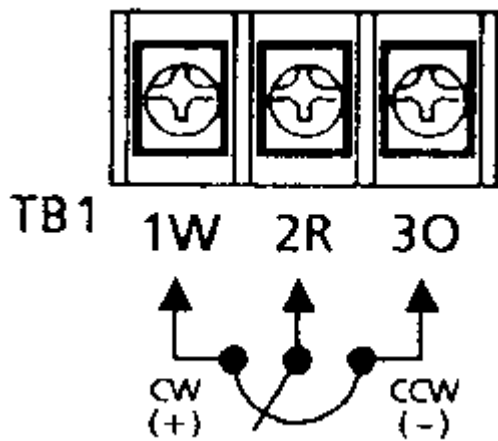

IMPORTANT

Only one form of speed control may be connected to the Bulletin 1331, either a 10k Ohm Potentiometer Control Input or a 0-10V DC Control Source.

CONTROL TERMINAL BLOCK TB1--ANALOG METER OUTPUT

0-1mA Analog Meter Output

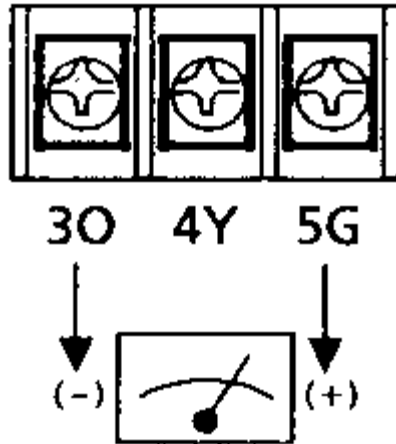

500 Ohm LOAD IMPEDANCE OR LESS

CONTROL TERMINAL BLOCK TB1--RUN/STOP INPUT

Run/Stop Control Input
5V DC Internal Source

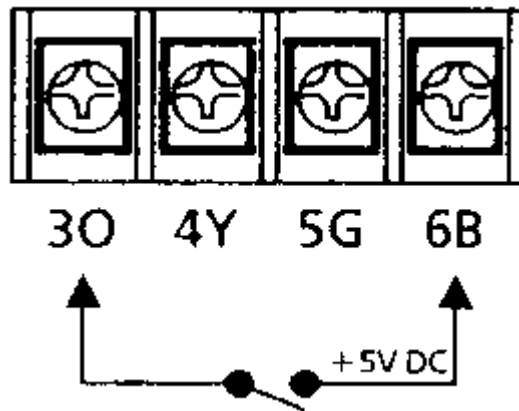

1ma Sinking Current
OPEN CONTACT = STOP
CLOSED CONTACT = RUN

CONTROL TERMINAL BLOCK TB1--FORWARD/REVERSE INPUT

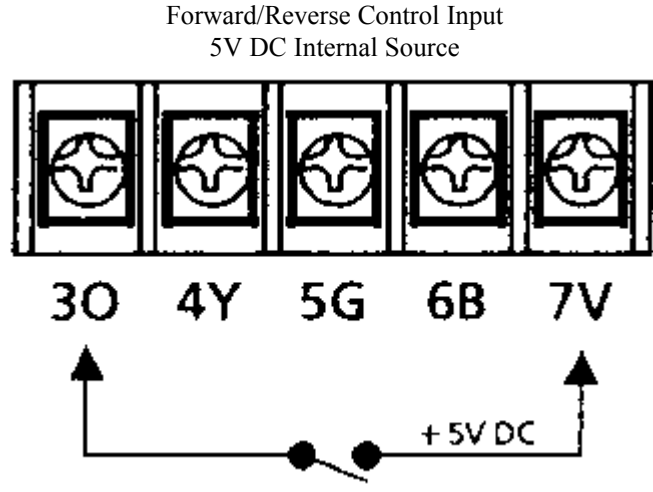

1 MA SINKING CURRENT
OPEN CONTACT = FORWARD
CLOSED CONTACT = REVERSE

CONTROL TERMINAL BLOCK TB1--FAULT CONTACT OUTPUTS

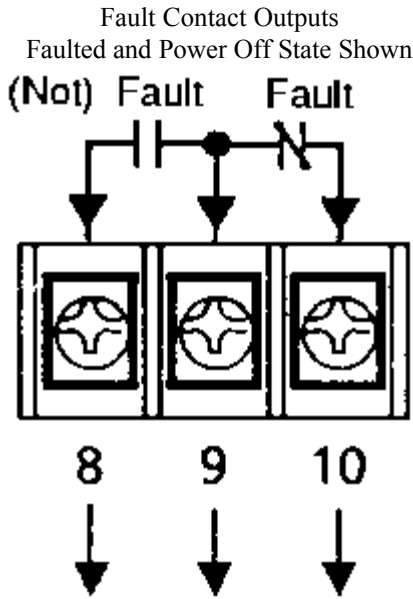

1NO/1NC FORM C CONTACT

120V AC
1A RESISTIVE
0.8A INDUCTIVE