

ZAA-EAA 3-Phase Power Terminal Block Wiring

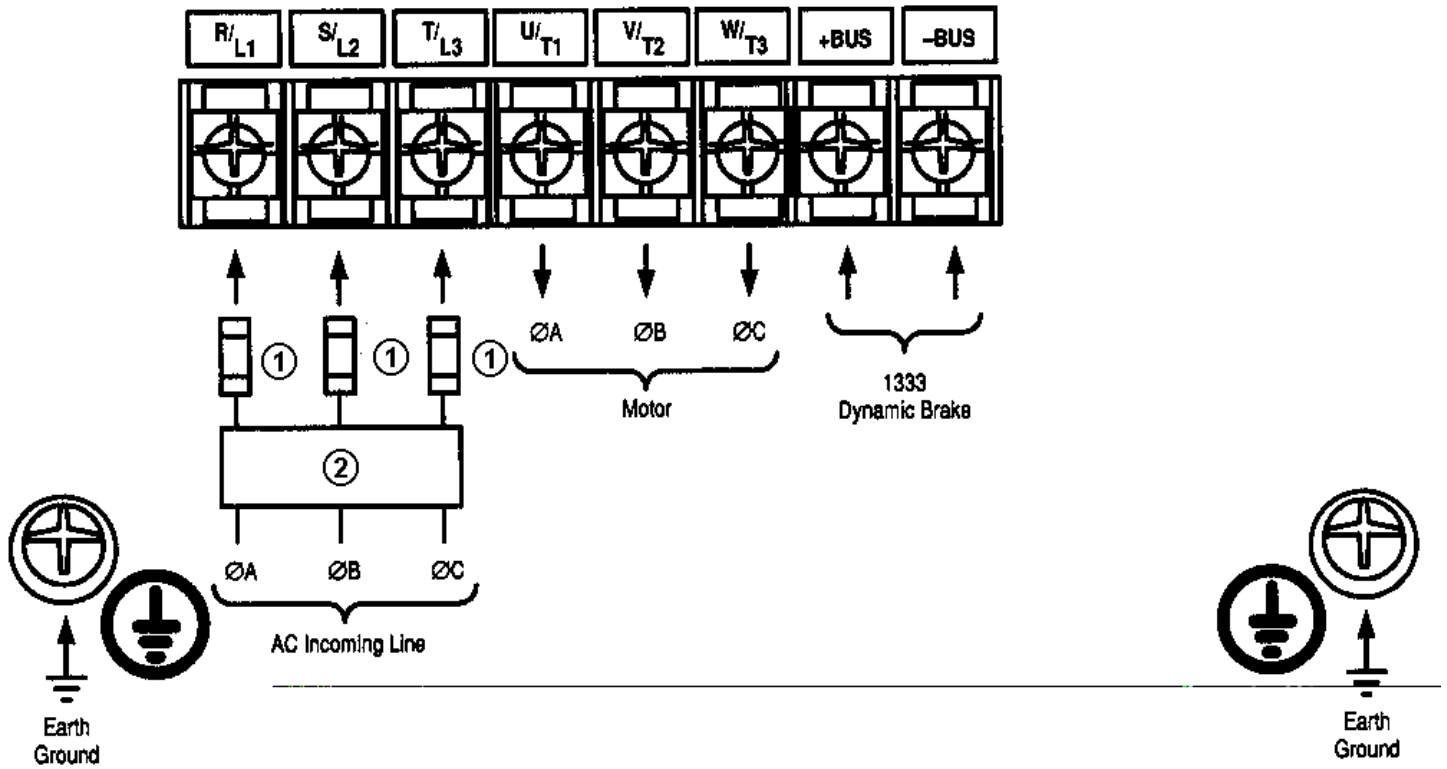

NOTES:

- (1) User supplied drive input fuses.
- (2) Motor disconnecting means including branch circuit, short circuit, and ground-fault protection.

R/L1, S/L2, T/L3 Input AC line Terminals are not phase sensitive.

For drives rated ZAA-EAA, nominal 3-phase input voltage is 200/208/230V AC, 50/60 Hz.

For drives rated AAB-CAB, nominal 3-phase input voltage is 380/415/460V AC, 50/60Hz.

Branch disconnect and short circuit protection is not part of the standard 1333 and must be supplied by the user. Drive input fuses are required to provide component protection against malfunction of electronic circuits.

U/T1, V/T2, W/T3

Connect the motor leads to these terminals.

+ BUS, - BUS

DC bus terminals are reserved for the 1333 dynamic brake option. Refer to the 1333 dynamic brake option instructions for installation and connection details.

GND

Two ground terminals have been provided in the drive. Either one of these terminals must be connected to earth ground or the ground of the building electrical system. The motor frame must also be connected to earth ground. Refer to the motor manufacturer's installation instructions for specific details.

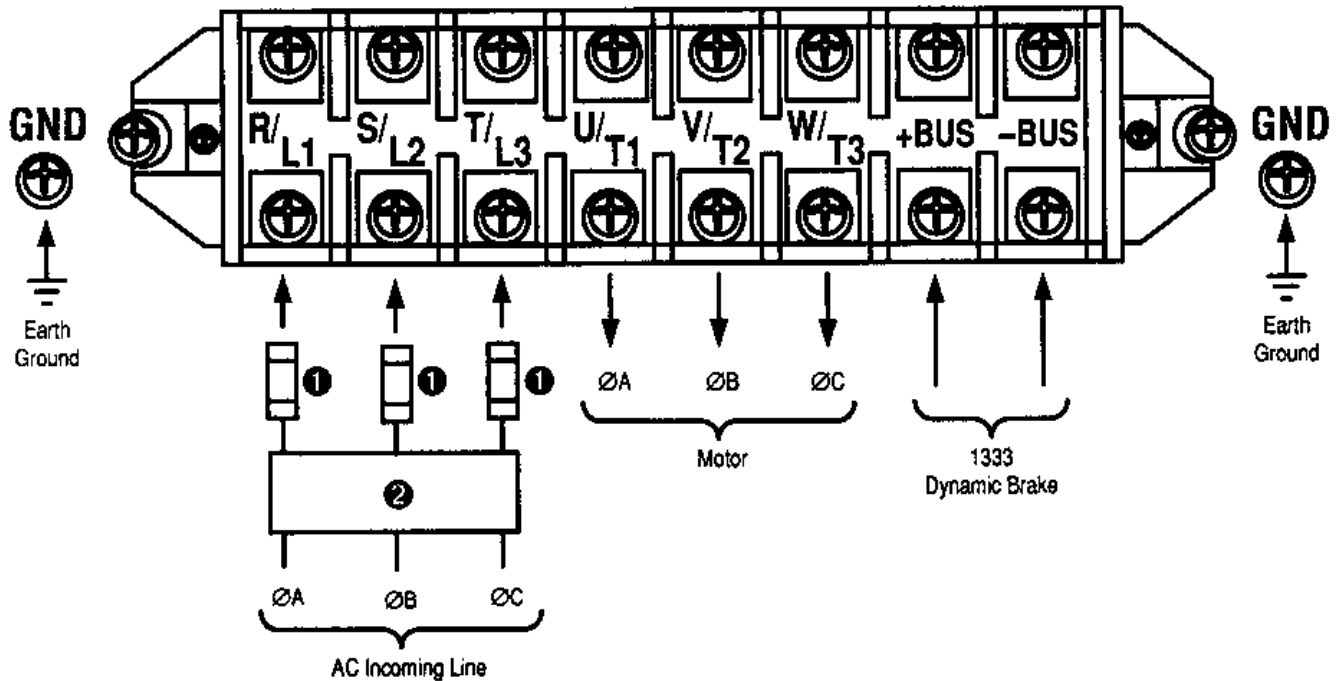

NOTES:

- (1) User supplied drive input fuses.
- (2) Motor disconnecting means including branch circuit, short circuit, and ground-fault protection.

R/L1 S/L2 T/L3

Input AC line Terminals are not phase sensitive.

For drives rated FAA or GAA, nominal 3-phase input voltage is 200/208/230V AC, 50/60 Hz.

Branch disconnect and short circuit protection is not part of the standard 1333 and must be supplied by the user. Drive input fuses are required to provide component protection against malfunction of electronic circuits.

U/T1, /T2, /T3

Connect the motor leads to these terminals.

+ BUS, - BUS

DC bus terminals are reserved for the 1333 dynamic brake option. Refer to the 1333 dynamic brake option instructions for installation and connection details.

GND

Two ground terminals have been provided in the drive. Either one of these terminals must be connected to earth ground or the ground of the building electrical system. The motor frame must also be connected to earth ground. Refer to the motor manufacturer's installation instructions for specific details.

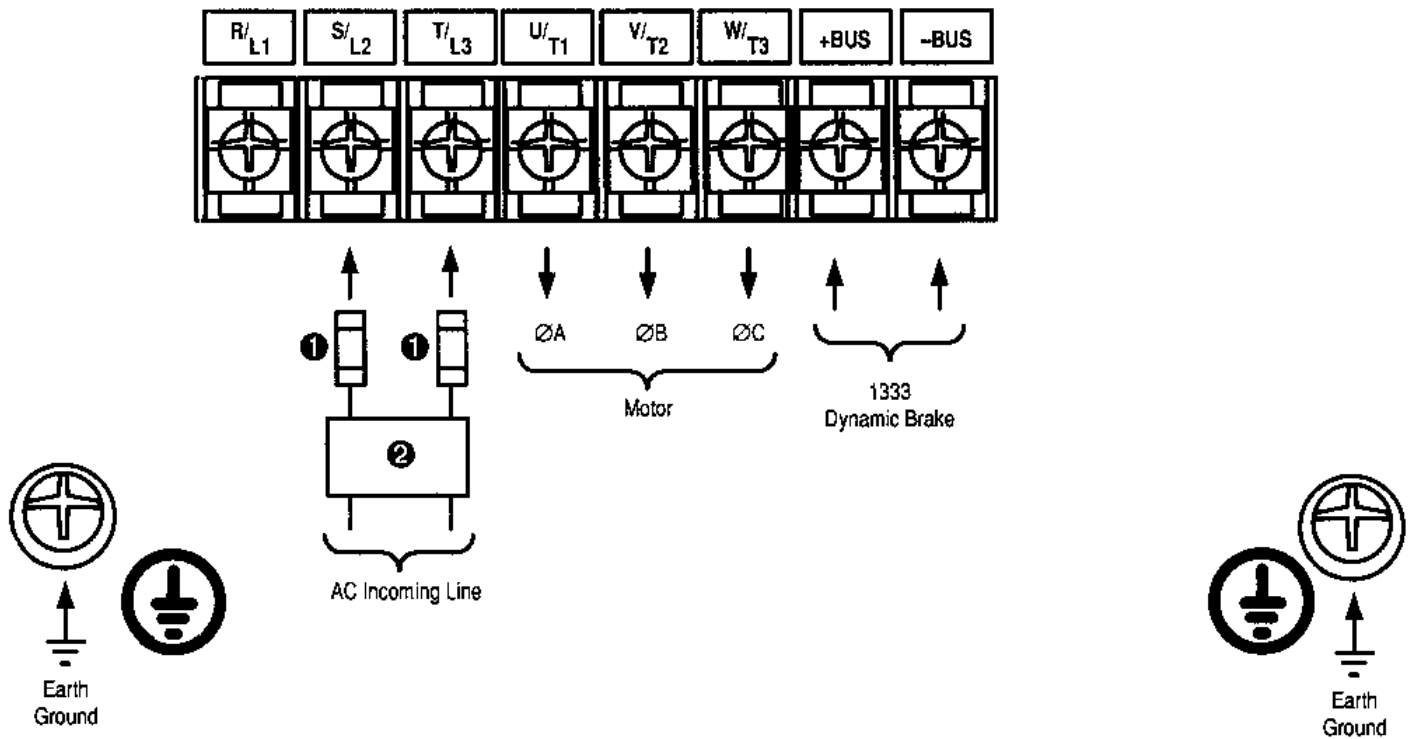

NOTES:

- (1) User supplied drive input fuses.
- (2) Motor disconnecting means including branch circuit, short circuit, and ground-fault protection.

S/L2 and T/L3

Input AC line Terminals are not phase sensitive.

For drives rated ZAA-EAA, nominal 1-phase input voltage is 200/208/230V AC, 50/60 Hz.

Branch disconnect and short circuit protection is not part of the standard 1333 and must be supplied by the user. Drive input fuses are required to provide component protection against malfunction of electronic circuits.

U/T1, V/T2, W/T3

Connect the motor leads to these terminals.

+ BUS, - BUS

DC bus terminals are reserved for the 1333 Dynamic Brake Option. Refer to the 1333 Dynamic Brake Option instructions for installation and connection details.

GND

Two ground terminals have been provided in the drive. Either one of these terminals must be connected to earth ground or the ground of the building electrical system. The motor frame must also be connected to earth ground. Refer to the motor installation instructions for specific details.

FAA - GAA 1 Phase
Power Terminal Block Wiring

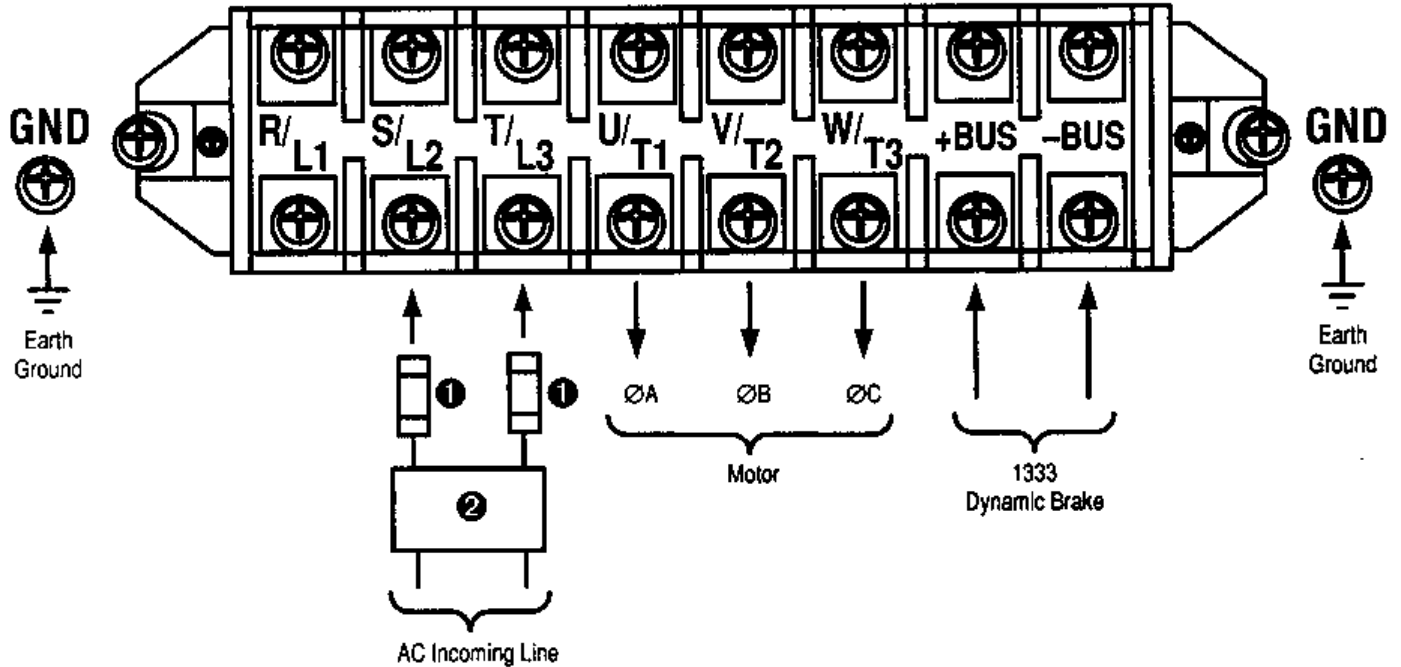

NOTES:

- (1) User supplied drive input fuses.
- (2) Motor disconnecting means including branch circuit, short circuit, and ground-fault protection.

S/L2 and T/L3

Input AC line Terminals are not phase sensitive.

For drives rated FAA or GAA, nominal 1-phase input voltage is 200/208/230V AC, 50/60 Hz.

Branch disconnect and short circuit protection is not part of the standard 1333 and must be supplied by the user. Drive input fuses are required to provide component protection against malfunction of electronic circuits.

U/T1, V/T2, W/T3

Connect the motor leads to these terminals.

+ BUS, - BUS

DC bus terminals are reserved for the 1333 Dynamic Brake Option. Refer to the 1333 Dynamic Brake Option instructions for installation and connection details.

GND

Two ground terminals have been provided in the drive. Either one of these terminals must be connected to earth ground or the ground of the building electrical system. The motor frame must also be connected to earth ground. Refer to the motor installation instructions for specific details.

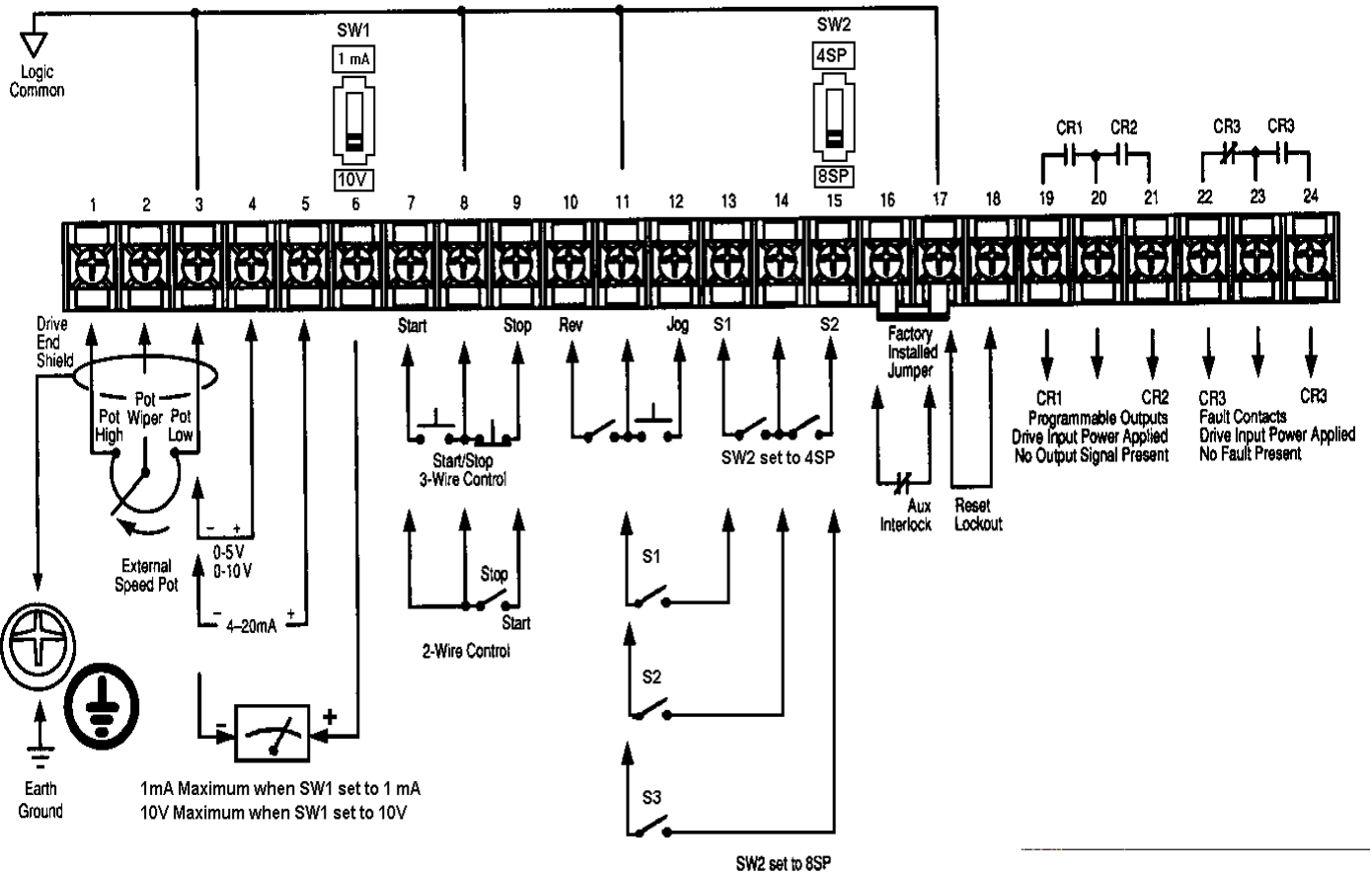

Control and Signal Wiring Terminal Block Interconnection Diagram

Input Signal Terminals	Input Signal	Recommended Wire Size	Recommended Torque
Terminals 1, 2, 3	External Speed Potentiometer	16 AWG (1.5mm ²)	7 In-Lbs (.791 N-m)
Terminals 3, 8, 11 and 17	Logic Common	16 AWG (1.5mm ²)	7 In-Lbs (.791 N-m)
Terminals 4 and 3	0-5 or 0-10V DC	16 AWG (1.5mm ²)	7 In-Lbs (.791 N-m)
Terminals 5 and 3	4-20mA	16 AWG (1.5mm ²)	7 In-Lbs (.791 N-m)
Terminals 7 and 8	Start	16 AWG (1.5mm ²)	7 In-Lbs (.791 N-m)
Terminals 9 and 8	Stop	16 AWG (1.5mm ²)	7 In-Lbs (.791 N-m)
Terminals 10 and 11	Reverse	16 AWG (1.5mm ²)	7 In-Lbs (.791 N-m)
Terminals 12 and 11	Jog	16 AWG (1.5mm ²)	7 In-Lbs (.791 N-m)
Terminals 13 and 14	S1/4SP Position	16 AWG (1.5mm ²)	7 In-Lbs (.791 N-m)
Terminals 14 and 15	S2/4SP Position	16 AWG (1.5mm ²)	7 In-Lbs (.791 N-m)
Terminals 11 and 13	S1/8SP Position	16 AWG (1.5mm ²)	7 In-Lbs (.791 N-m)
Terminals 11 and 14	S2/8SP Position	16 AWG (1.5mm ²)	7 In-Lbs (.791 N-m)
Terminals 11 and 15	S3/8SP Position	16 AWG (1.5mm ²)	7 In-Lbs (.791 N-m)
Terminals 16 and 17	Auxiliary Interlock	16 AWG (1.5mm ²)	7 In-Lbs (.791 N-m)
Terminals 17 and 18	Reset Lockout	16 AWG (1.5mm ²)	7 In-Lbs (.791 N-m)

Output Signal Terminals	Output Signal	Recommended Wire Size	Recommended Torque
Terminal 6 and Logic Common	0-1mA or 0-10V Meter	16AWG(1.5mm ²)	7In-Lbs(.791 N-m)
Terminals 19 and 20	CR1 Programmable Contact	16 AWG (1.5mm ²)	7 In-Lbs (.791 N-m)
Terminals 20 and 21	CR2 Programmable Contact	16 AWG (1.5mm ²)	7 In-Lbs (.791 N-m)
Terminals 22 and 23	CR3 Fault Contact	16 AWG (1.5mm ²)	7 In-Lbs (.791 N-m)
Terminals 23 and 24	CR3 Fault Contact	16 AWG (1.5mm ²)	7 In-Lbs (.791 N-m)