



ALLEN-BRADLEY BULLETIN 1336 MANUAL BYPASS

APPLICATION NOTE #11

January 2, 1997

PURPOSE

The purpose of this document is to provide guidelines for wiring and control schemes for the Bulletin 1336 AC Drive. This document is to be used as a suggestion only. Users must ensure that installations meet applicable codes and are suitable for the existing conditions.

The Bulletin 1336 User Manual should be used as a reference to ensure that proper wire selection, routing, and fusing guidelines are followed.

WHAT THIS NOTE CONTAINS

The Bulletin 1336 is used in many applications that are also suited for "line" operation. Some examples are fans and pumps. To enhance the system capability, the drive can be configured with a bypass circuit.

The Bypass circuit allows the drive to be disconnected for maintenance purposes while the application is run from the line supply. The Bypass circuit can be configured for manual

or automatic transfer from drive to line operation. This note will discuss the Manual Bypass circuit.

INTENDED AUDIENCE

This application note is intended to be used by personnel familiar with the hardware components and programming procedure necessary to operate the Bulletin 1336/1336VT.

WHERE IT IS USED

The diagrams, parameter settings, and auxiliary hardware used in this application note are designed to address specific issues in many different applications. Some changes by the Users may be necessary to apply the concepts of this document to a specific application.

TERMS AND DEFINITIONS

Output Contactor - labeled 2K, is located between the drive and the motor.

Bypass Contactor - labeled 3K, is located between the line supply and the motor.

DESCRIPTION

The typical control circuit for the Drive and Bypass functions include HAND/OFF/AUTO (H/O/A) and DRIVE/BYPASS selector switches. The DRIVE/BYPASS switch selects between drive and line operation. The H/O/A switch functions as follows:

OFF - output contactor and bypass contactor open.
HAND - starts the motor with the DRIVE/BYPASS switch in either position.
AUTO - requires a remote RUN command to start the motor.

The "on-delay" timer (2TR) is used to ensure that the Output contactor (2K) auxiliary contact is closed prior to starting

the drive. The "off-delay" timer (1TR) ensures that the drive is off prior to opening the output contactor.

2TR is further used in the start/stop control circuit for drive operation.

The Output contactor (2K) and Bypass contactor (3K) are interlocked with auxiliary contacts to ensure that only one of them is closed at any given time.

For increased system flexibility a main disconnect switch (1DS) and a separate drive disconnect switch (2DS) are used.

This allows power to be removed during Bypass operation for maintenance purposes. The auxiliary contacts from the drive disconnect switch are used to remove the control power from the Logic Interface board.

A REMOTE/LOCAL selector switch is used to switch between two different frequency references. The Users may choose to

have the H/O/A switch perform this function with an additional contact block. A typical operation with the H/O/A switch is as follows:

HAND - selects a door mounted speed pot (not shown).
AUTO - selects a remote analog speed reference (not shown).

Refer to figure 1 for diagram.

MANUAL BYPASS

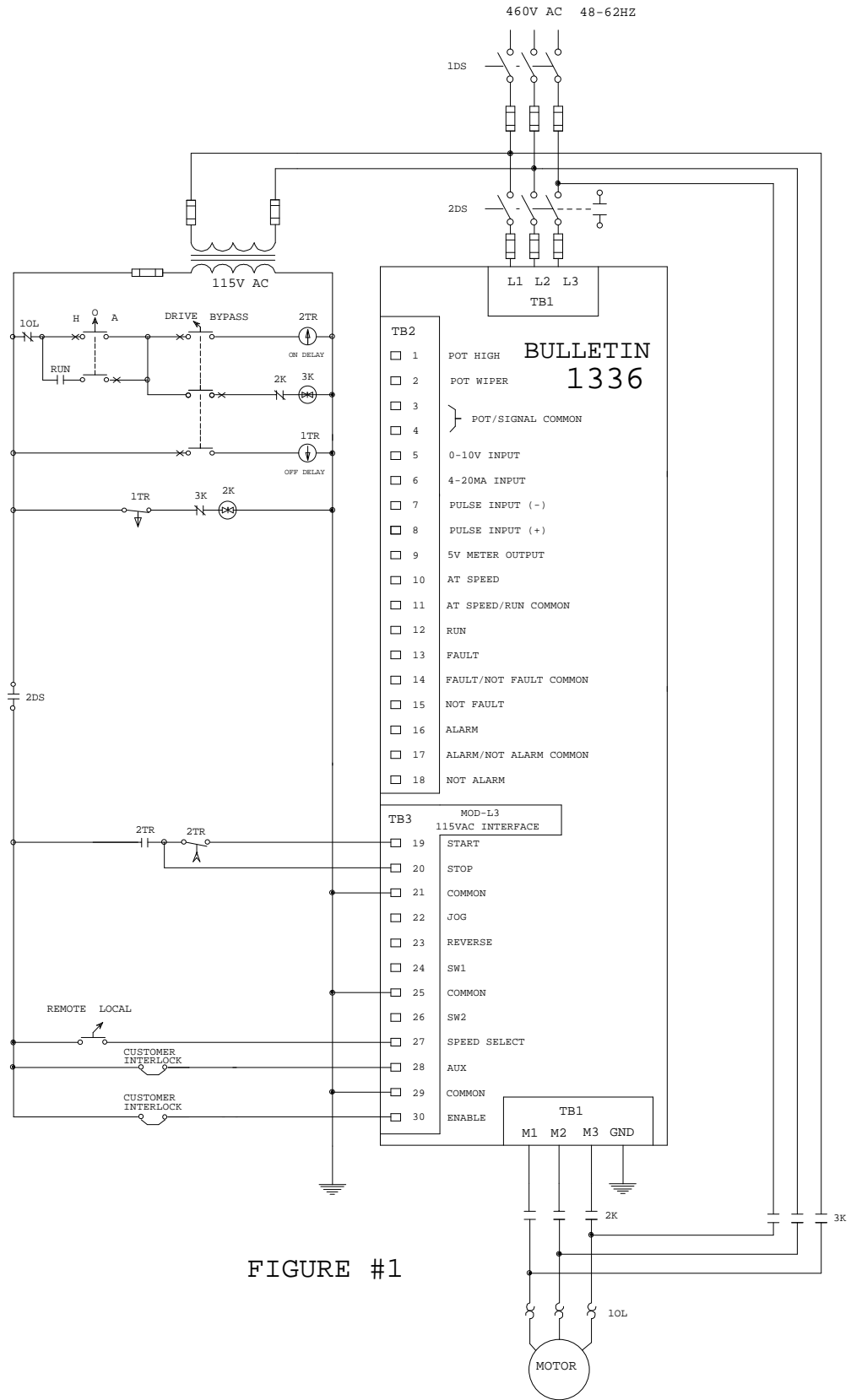

FIGURE #1