



**ALLEN-BRADLEY
BULLETIN 1336
LOGIC INTERFACE BOARD
COMPATIBILITY**

APPLICATION NOTE #15

January 2, 1997

PURPOSE

The purpose of this document is to provide guidelines for wiring and control schemes for the Bulletin 1336 AC Drive. This document is to be used as a suggestion only. Users must

ensure that installations meet applicable codes and are suitable for the existing conditions.

The Bulletin 1336 User Manual should be used as a reference to ensure that proper wire selection, routing, and fusing guidelines are followed.

**WHAT THIS NOTE
USE
CONTAINS**

The Bulletin 1336 Logic Interface cards are designed for use with "hard contacts" from push buttons, selector switches, or relays. However, many installations utilize a PLC for control. These outputs are solid state switches not hard contacts; and have a "leakage" current rating that must be verified to ensure compatibility with the Logic Interface board being used.

**INTENDED
AUDIENCE**

This application note is intended to be used by personnel familiar with the hardware components and programming procedure necessary to operate the Bulletin 1336/1336VT.

**WHERE IT
IS USED**

changes

The diagrams, parameter settings, and auxiliary hardware used in this application note are designed to address specific issues in many different applications. Some

by the Users may be necessary to apply the concepts of this document to a specific application.

**TERMS AND
DEFINITIONS**

1336-MOD-L1 TTL Logic Interface (low = true logic)
1336-MOD-L2 24VDC Logic Interface (high = true logic)
1336-MOD-L3 115Vac Logic Interface (high = true logic)

DESCRIPTION

1336-MOD-L1 This interface board uses a TTL type logic. The drive sources the 5VDC that is present on the control terminals for the various functions. To command a given function, the terminal must be "pulled" low to one of the common terminals, TB3 21,25, or 29. Refer to publication 1336-5.71 for installation data.

Logic reed type contacts or contacts rated for low power circuits should be used with this interface board, such as: Bulletin 700-CPR, 800T-XAR, or 800M-XAR.

ALLEN-BRADLEY programmable controller modules that can be used are the 1771-OYL and 1771-OZL contact output modules.

1336-MOD-L2 The 24VDC interface module requires the Users to supply the voltage to the control terminals. The return, or common, of the 24VDC power supply should be connected to the Logic Interface common at TB3 terminals 21,25, and 29. Refer to publication 1336-5.72 for installation data.

Logic reed type contacts or contacts rated for low power circuits should be used with this interface board, such as: Bulletin 700-CPR, or 800T-XAR. The standard 800M contacts will work reliably.

ALLEN-BRADLEY programmable controller modules that can be used are as follows:

1771-OB	1771-OB D	1771-OB N
1771-OQ	1771-OQ16	1771-OYL
1771-OZL	1746-OB8	1746-OB16

1336-MOD-L3 This Logic interface board requires the Users to supply 115VAC to the control terminals for a given function. The return, or common, of the 115VAC supply should be terminated at the Logic Interface common TB3 21,25, and 29. Refer to publication 1336-5.73 for installation data.

Standard push button and relay contacts can be used with this interface board since there is enough power in the circuit to maintain reliable contact continuity.

The 1771-OW and 1771-OWN contact modules can be used for interfacing to A-B programmable controllers. Although the module specifications state that the minimum contact load is 10ma, the 8ma load of the MOD-L3 is sufficient for reliable operation.

If solid state switches are used, the leakage current rating of the switch must be less than 1ma. For PLC output modules such as 1771-OA, 1771-OAD, and 1771-OD16 with leakage currents of 1-5ma, a 2.5K ohm/10 watt burden resistor must be placed in the circuit. The burden resistor should be

to between the input being used and the common on TB3. Refer figures 1 and 2 for diagram.

1336-MOD-L3 INTERFACE WITH SOLID STATE INPUTS

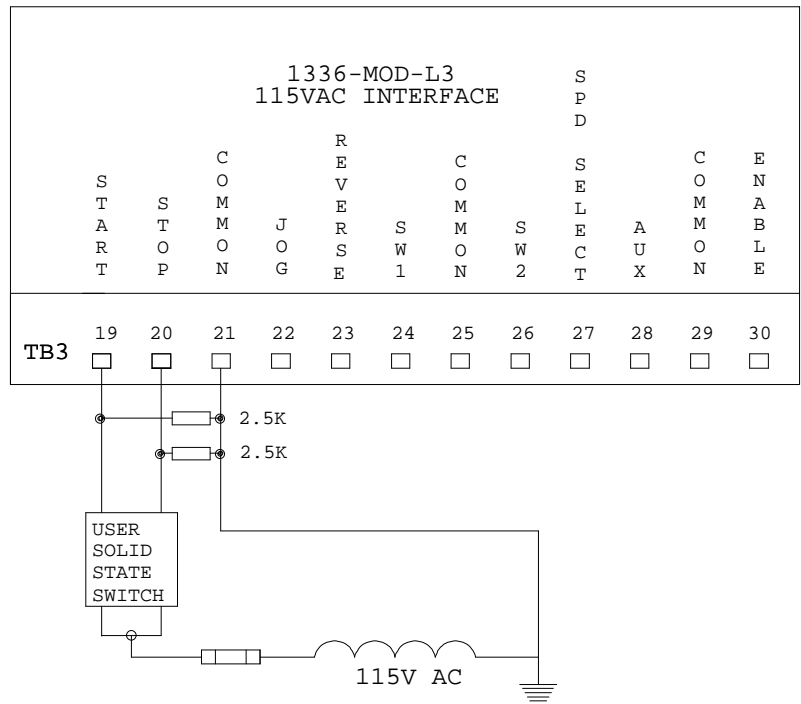

FIGURE #1

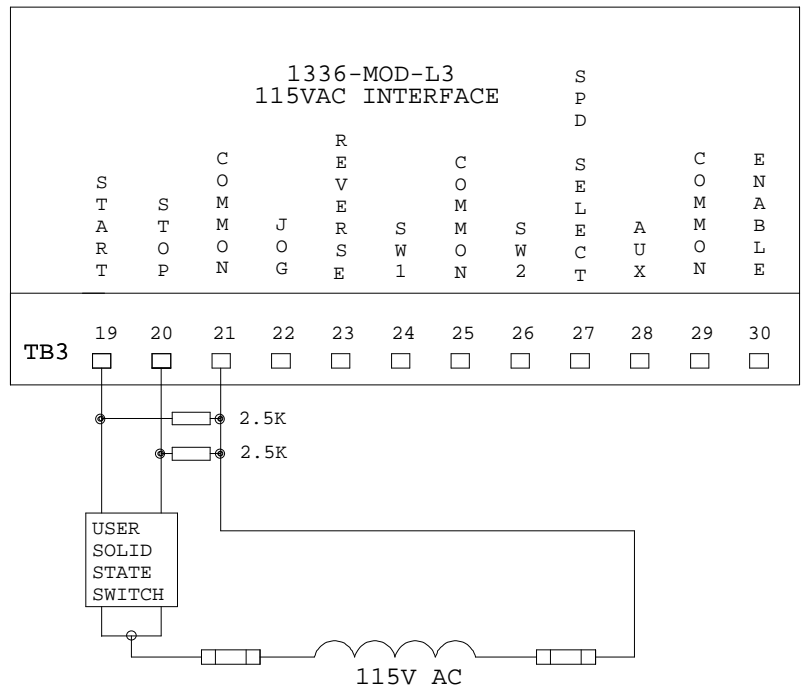

FIGURE #2