

POWER WIRING --- TB 1

Input and output power connections are performed through a ten position terminal block TB1. For maintenance and set up procedures, the drive may be operated without a motor connected.



ATTENTION: Any disconnecting means wired to drive output terminals U, V, and W must be capable of disabling the drive if opened during drive operation. If opened during drive operation, the drive will continue to produce output voltage between U, V, W and the motor. An auxiliary contact must be used to simultaneously disable the drive.

**200-240/380-480/500-600V
0.37-3.7 kW (0.5-5 HP) Terminal Designations**

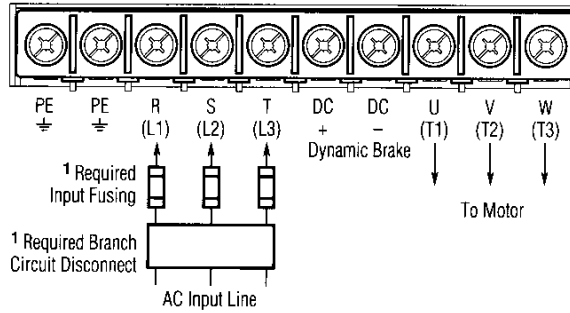

**200-240V, 5.5 kW (7.5 HP) Terminal Designations
380-480/500-600V, 5.5-11 kW (7.5-15 HP) Terminal Designations**

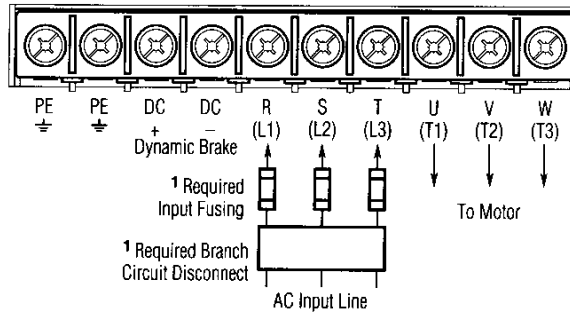

**200-240V, 7.5-11 kW (10-15 HP) Terminal Designations
380-480/500-600V, 15-22 kW (20-30 HP) Terminal Designations**

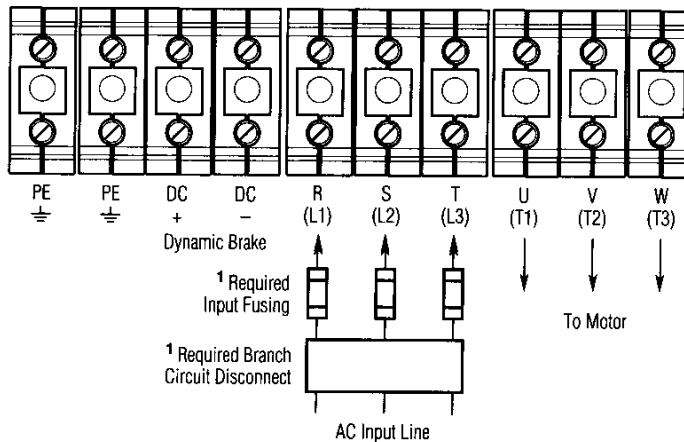

¹ User Supplied.

BULLETIN 1336 PLUS

CONTROL AND SIGNAL WIRING --- TB2

TB2 is located at the bottom of the Main Control Board. 0.37-3.7 kW (0.5-5 HP) drives have eighteen positions, 5.5 kW (7.5 HP) and up have twenty-two positions.

The maximum and minimum wire size accepted by TB2 is 1.5 and 0.20 mm² (14 and 24 AWG). Maximum torque for all terminals is 0.90 N-m (8 lb-in). The recommended control signal wire is:

Belden 8760 (or equivalent) — 0.750 mm² (18 AWG), twisted pair, shielded.

Belden 8770 (or equivalent) — 0.750 mm² (18 AWG), 3 conductor, shielded.

Belden 9460 (or equivalent) — 0.750 mm² (18 AWG), twisted pair, shielded.

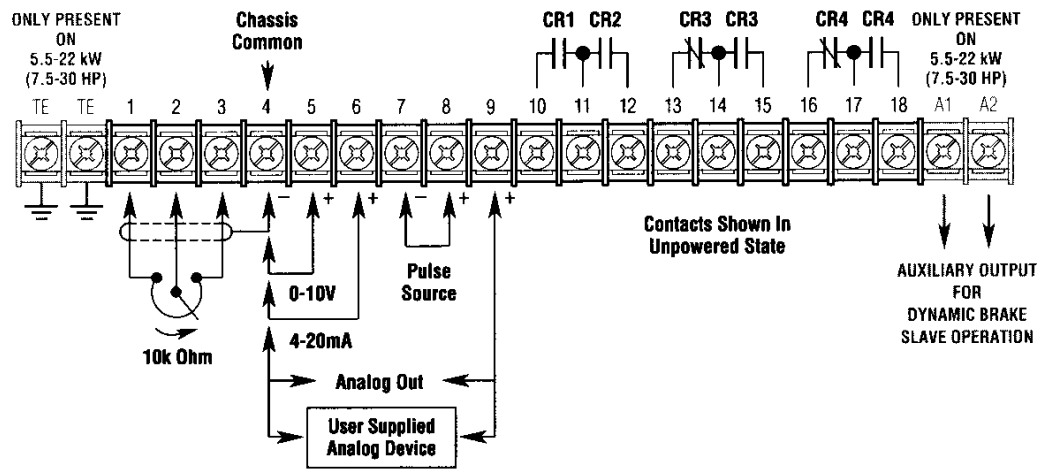

TERMINAL BLOCK TB2 SPECIFICATIONS

Terminal Number(s)	Signal	
TE	Logic Earth Ground	
1, 2, 3	External Speed Pot or Analog Trim Pot	(10k Ohm Pot Required)
4	Signal Common	
5	0-10V DC Input:	Impedance = 100k Ohms
6	4-20 mA Input:	Impedance = 250 Ohms
7, 8	Pulse Input for Frequency Reference	+5V DC — Scale Factor (Encoder PPR) Must Be Set
9	Analog Output:	
	0.37 - 3.7 kW (0.5 - 5 HP)	Jumper JP1 to Select 0-10V DC Output Jumper JP2 to Select 4-20 mA Output
	5.5 - 22 kW (7.5 - 30 HP)	Jumper J5 Selects Output: Pins 1-2 = 4-20 mA Pins 3-4 = 0-10V DC
10, 11	CR1 Programmable Contact	Resistive Rating = 115V AC/30V DC, 5.0A Inductive Rating = 115V AC/30V DC, 2.0A
11, 12	CR2 Run Contact	Resistive Rating = 115V AC/30V DC, 5.0A Inductive Rating = 115V AC/30V DC, 2.0A
13, 14	CR3 Fault Contact	Resistive Rating = 115V AC/30V DC, 5.0A
14, 15	CR3 Fault NOT Contact	Inductive Rating = 115V AC/30V DC, 2.0A
16, 17	CR4 Alarm Contact	Resistive Rating = 115V AC/30V DC, 5.0A
17, 18	CR4 Alarm NOT Contact	Inductive Rating = 115V AC/30V DC, 2.0A
A1, A2	Auxiliary Output	Used Only with Dynamic Brake in Slave Configuration

BULLETIN 1336 PLUS
CONTROL INTERFACE WIRING
 --- TB 3

User control interface inputs are connected through TB3 on the L4/L4E, L5/L5E and L6/L6E Option Board. Each board has nine control inputs. The function of each input must be selected through programming.

A variety of combinations made up of the following inputs are available.

Start	2 Accel/Decel Rates	2 Stop Mode Selects
Stop/Clear Fault	3 Speed Selects	Run Forward
Reverse	Enable	Run Reverse
Digital Potentiometer (MOP)	Auxiliary	Local Control



ATTENTION: The drive is intended to be controlled by control input signals that will start and stop the motor. A device that routinely disconnects then reapplies line power to the drive for the purpose of starting and stopping the motor is not recommended. If this type of stopping is used, a maximum of 3 stops in any 5 minute period with a minimum 1 minute rest between each is imposed. Wait 10 minutes before attempting the next 3 hardwired stop cycles to allow the drive precharge resistors to cool. Refer to codes and standards applicable to your particular system for specific requirements and additional information.



ATTENTION: User speed reference signals are terminated to chassis ground at TB2 terminals 3 & 4. This puts the negative or common side of these signals at earth ground potential. Control schemes should be examined for possible conflict with this grounding scheme.

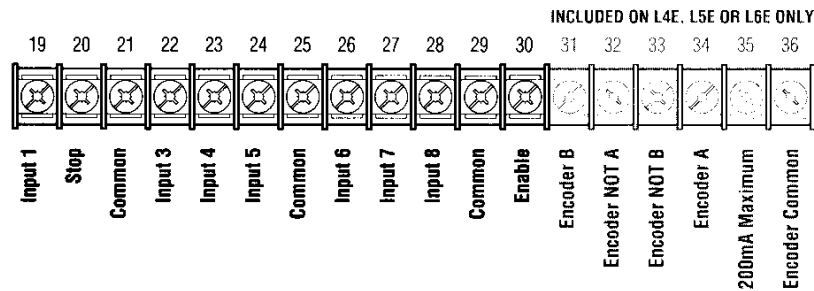

The maximum and minimum wire size accepted by TB3 is 1.5 and 0.20 mm² (14 and 24 AWG). Maximum torque for all terminals is 0.90 N-m (8 lb-in).

TYPICAL TB3 ENCODER CONNECTIONS

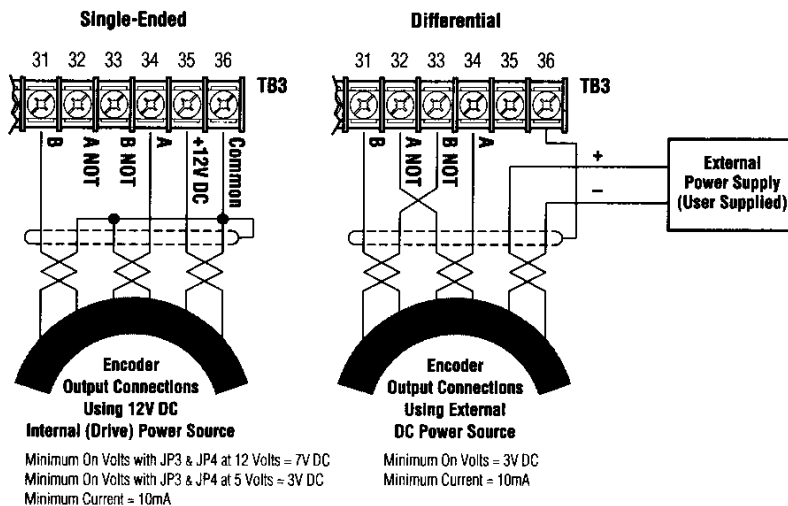

Note: Control Interface Board jumpers JP3 & JP4 must be set for the voltage level of the encoder output.

BULLETIN 1336 PLUS

CONTROL INTERFACE WIRING --- TB 3

Input Mode Selection and Typical TB3 Connections

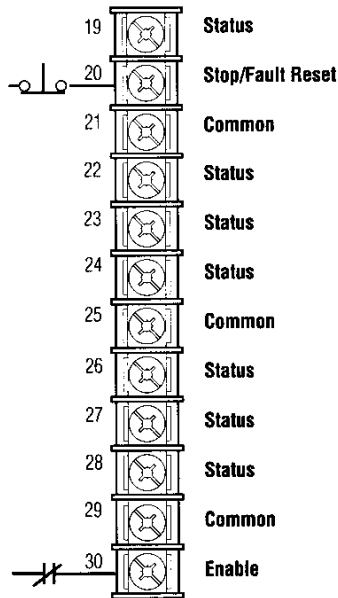
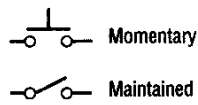

[Input Mode] 1 Factory Default

Note: If status is selected, the inputs can be read at the [Input Status] parameter, but they will have no control function.

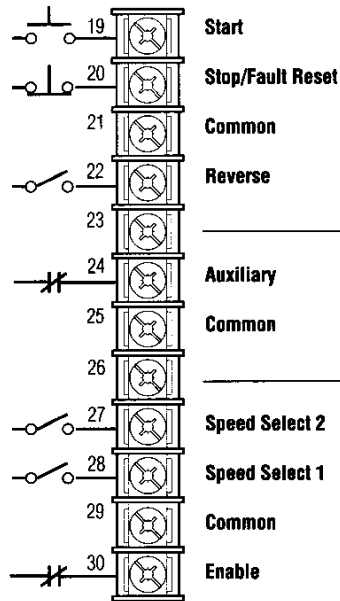

[Input Mode] 2-6 Three-Wire Control with Single-Source Reversing

Note: Drive must be stopped to take Local Control. Control by all other adapters is disabled except **Stop**.

	Mode				
	2	3	4	5	6
Reverse	Jog	Stop Type	2nd Accel	Digital Pot Up	Jog
Auxiliary	Speed Select 3	Speed Select 3	2nd Decel	Digital Pot Dn	Local Control

BULLETIN 1336 PLUS

CONTROL INTERFACE WIRING
-- TB 3

Input Mode Selection and Typical TB3 Connections

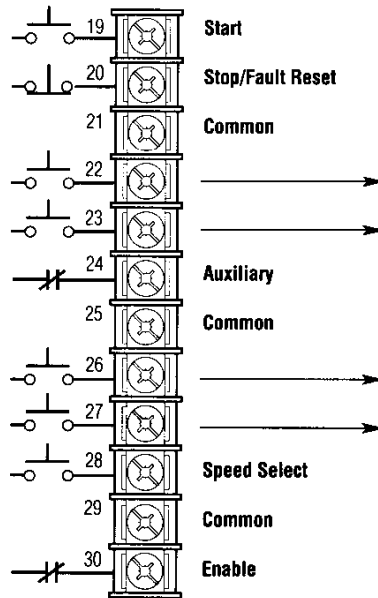
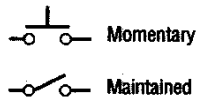

[Input Mode] 7-11 Three-Wire Control with Multi-Source Reversing

		Mode				
		7	8	9	10	11
Reverse	Reverse	Reverse	Digital Pot Up	Reverse	1st Accel	
Forward	Forward	Forward	Digital Pot Dn	Forward	2nd Accel	
Jog	Speed Select 3	Speed Select 3	Digital Pot Up	1st Decel		
Speed Select 2	Speed Select 2	Speed Select 2	Digital Pot Dn	2nd Decel		

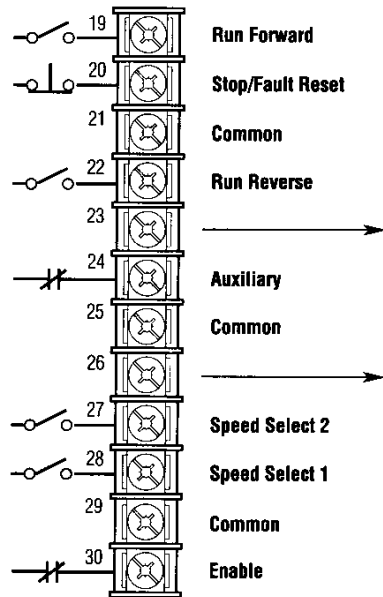

[Input Mode] 12-16 Two-Wire Control, Single-Source Control

Note: Drive must be stopped to take Local Control. Control by all other adapters is disabled except **Stop**.

		Mode				
		12	13	14	15	16
Local Control	Stop Type	2nd Accel	Digital Pot Up	Local Control		
Speed Select 3	Speed Select 3	2nd Decel	Digital Pot Dn	Stop Type		