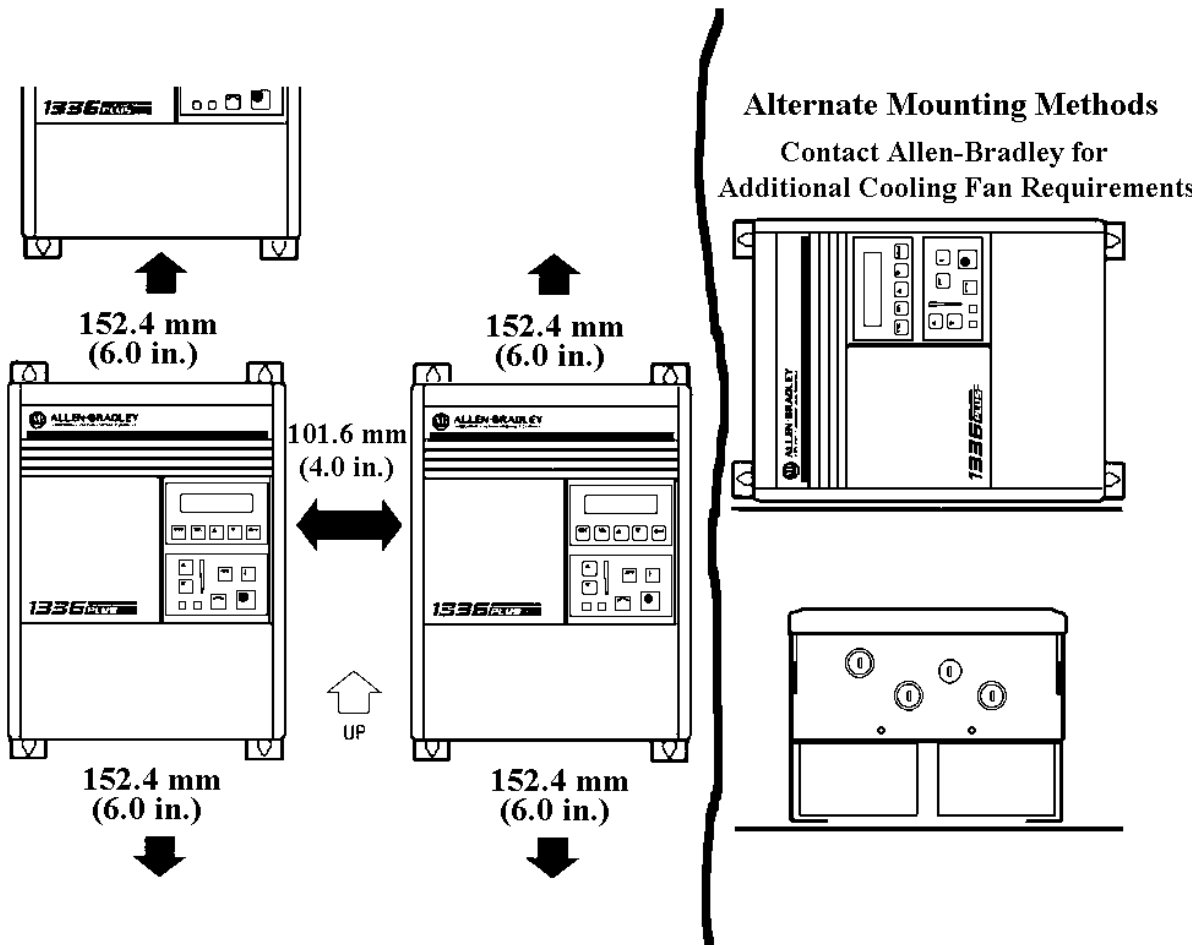


# 1336 PLUS Dimensions and Mounting Requirements

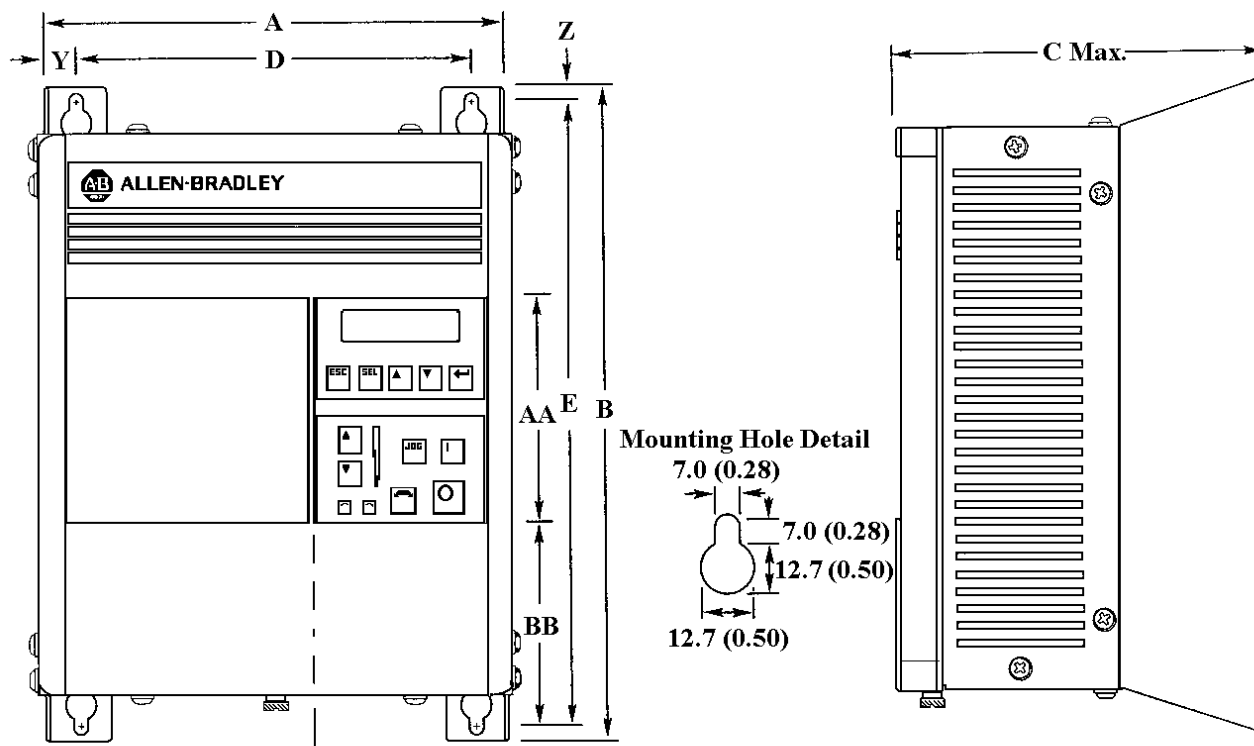
**ATTENTION:** The following information is merely a guide for proper installation. The Allen-Bradley Company cannot assume responsibility for the compliance or the noncompliance to any code, national, local or otherwise for the proper installation of this drive or associated equipment. A hazard of personal injury and/or equipment damage exists if codes are ignored during installation.

## Mounting

**Figure 1**  
**Minimum Mounting Requirements for Proper Heat Dissipation**  
(Dimensions shown are between drives or other devices)

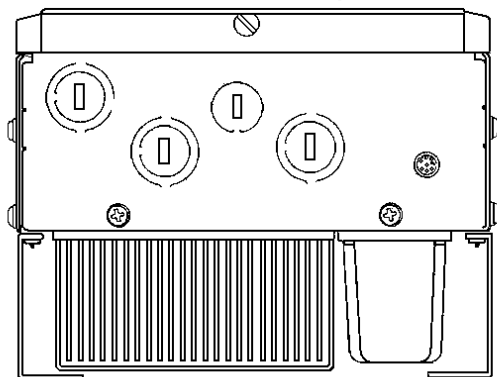


**Figure 2A.**  
**IP 20 (NEMA Type 1) Dimensions - Frames A1, A2, A3**



Mounting Holes (4) - See Detail

Bottom View Will Vary with HP



Three Phase Rating <sup>1,2</sup>			Frame Reference
200-240V	380-480V	500-600V	
0.37-0.75 kW 0.5-1 HP	0.37-1.2 kW 0.5-1.5 HP	—	A1
1.2-1.5 kW 1.5-2 HP	1.5-2.2 kW 2-3 HP	—	A2
2.2-3.7 kW 3-5 HP	3.7 kW 5 HP	—	A3
5.5-11 kW 7.5-15 HP	5.5-22 kW 7.5-30 HP	5.5-15 kW 7.5-20 HP	B
15-22 kW 20-30 HP	30-45 kW 40-60 HP	18.5-45 kW 25-60 HP	C
30-45 kW 40-60 HP	45-112 kW 60-150 HP	56-93 kW 75-125 HP	D
56-75 kW 75-100 HP	112-187 kW 150-250 HP	112-149 kW 150-200 HP	E

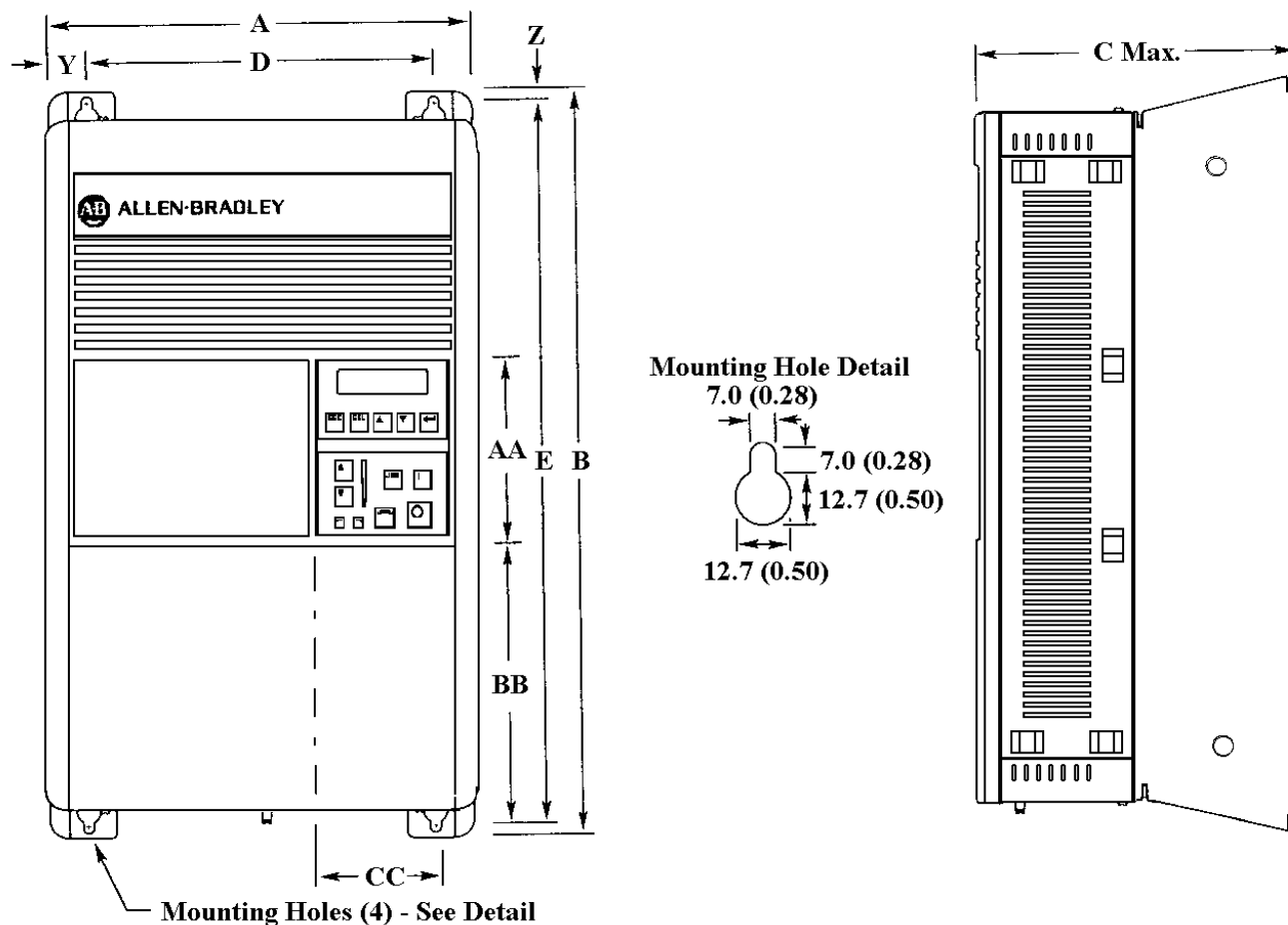
All Dimensions in Millimeters and (Inches)  
 All Weights in Kilograms and (Pounds)

Frame <sup>1,2</sup> Reference	A	B	C Max.	D	E	Y	Z	AA	BB	CC	Knockouts 3 Dual Size, 1-Fixed	Shipping Weights
A1	215.9 (8.50)	290.0 (11.42)	160.0 (6.30)	185.2 (7.29)	275.0 (10.83)	15.35 (0.60)	7.5 (0.30)	130.0 (5.12)	76.2 (3.00)	85.3 (3.36)	22.2/28.6, 22.2 (0.875/1.125, 0.875)	4.31 kg (9.5 lbs.)
A2	215.9 (8.50)	290.0 (11.42)	180.5 (7.10)	185.2 (7.29)	275.0 (10.83)	15.35 (0.60)	7.5 (0.30)	130.0 (5.12)	76.2 (3.00)	85.3 (3.36)	22.2/28.6, 22.2 (0.875/1.125, 0.875)	5.49 kg (12.1 lbs.)
A3	215.9 (8.50)	290.0 (11.42)	207.0 (8.15)	185.2 (7.29)	275.0 (10.83)	15.35 (0.60)	7.5 (0.30)	130.0 (5.12)	76.2 (3.00)	85.3 (3.36)	22.2/28.6, 22.2 (0.875/1.125, 0.875)	6.71 kg (14.8 lbs.)

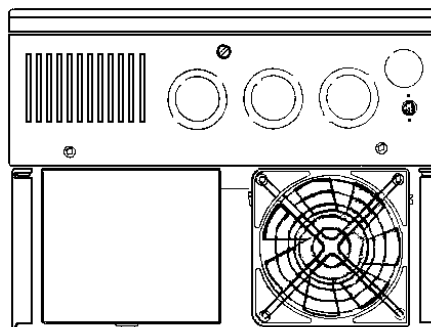
<sup>1</sup> Refer to Chapter 1 (Publication 1336 PLUS 5.0) for catalog numbers and Appendix for derating info.

<sup>2</sup> KW/HP are constant torque (CT) ratings.

**Figure 2B.**  
**IP 20 (NEMA Type 1) Dimensions - Frames B, C, D**



**Bottom View Will Vary with HP**



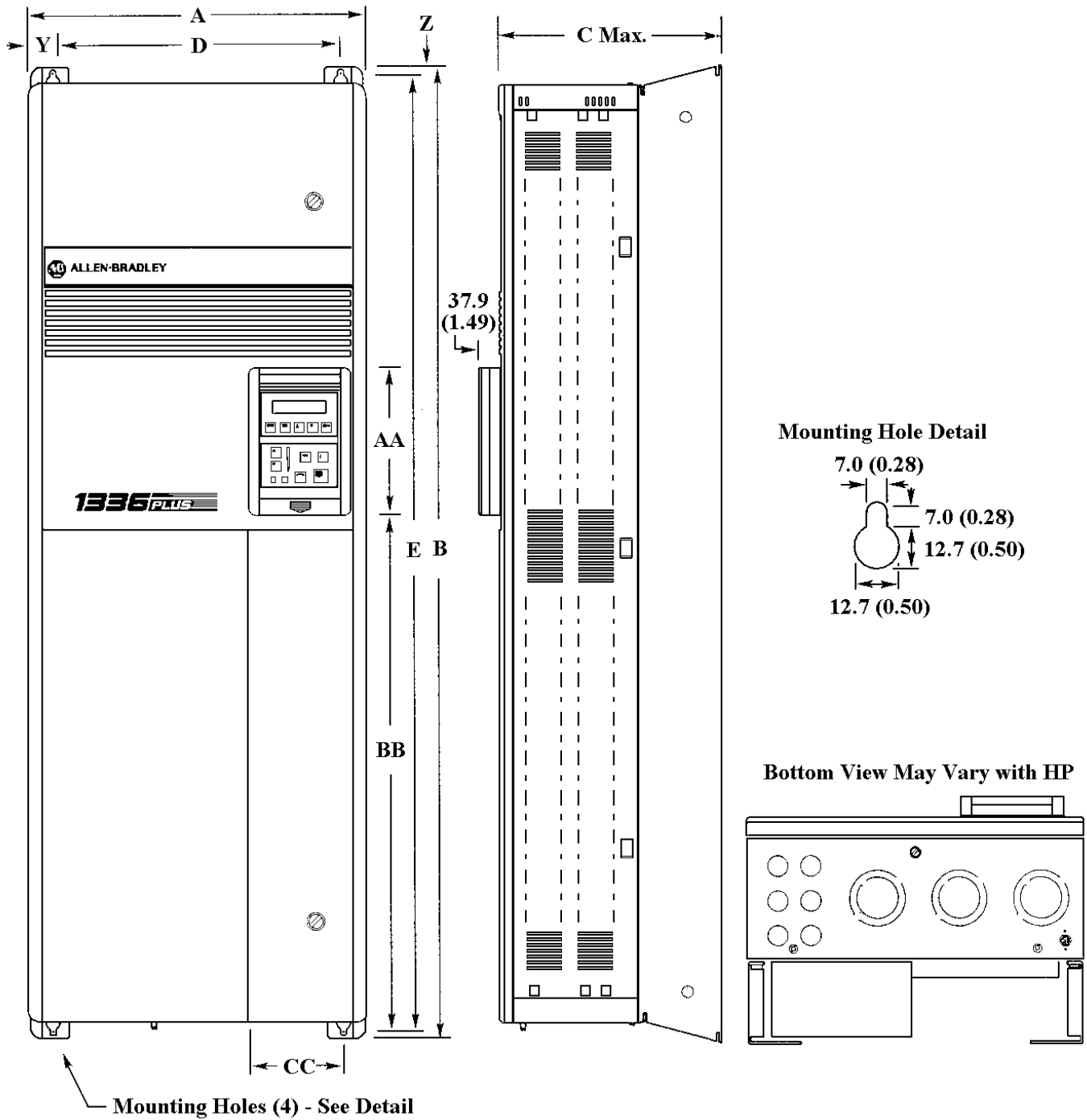
Frame Reference	Knockouts Dual Size and Fixed
B	2 - 28.6/34.9, 1 - 22.2 (2 - 1.125/1.375, 1 - 0.875)
C	2 - 28.6/34.9, 1 - 22.2 (2 - 1.125/1.375, 1 - 0.875)
D	2 - 62.7/76.2, 1 - 34.9/50.0, 3 - 34.9 (2 - 2.469/3.0, 1 - 1.375/1.968, 3 - 1.375)

All Dimensions in Millimeters and (Inches)

All Weights in Kilograms and (Pounds)

Frame Reference	A	B	C Max.	D	E	Y	Z	AA	BB	CC	Shipping Weight
B	276.4 (10.88)	476.3 (18.75)	225.0 (8.86)	212.6 (8.37)	461.0 (18.15)	32.00 (1.26)	7.6 (0.30)	131.1 (5.16)	180.8 (7.12)	71.9 (2.83)	22.7 kg (50 lbs.)
C	301.8 (11.88)	701.0 (27.60)	225.0 (8.86)	238.0 (9.37)	685.8 (27.00)	32.00 (1.26)	7.6 (0.30)	131.1 (5.16)	374.7 (14.75)	71.9 (2.83)	38.6 kg (85 lbs.)
D	381.5 (15.02)	1240.0 (48.82)	270.8 (10.66)	325.9 (12.83)	1216.2 (47.88)	27.94 (1.10)	11.94 (0.47)	131.1 (5.16)	688.6 (27.11)	83.6 (3.29)	108.9 kg (240 lbs.)

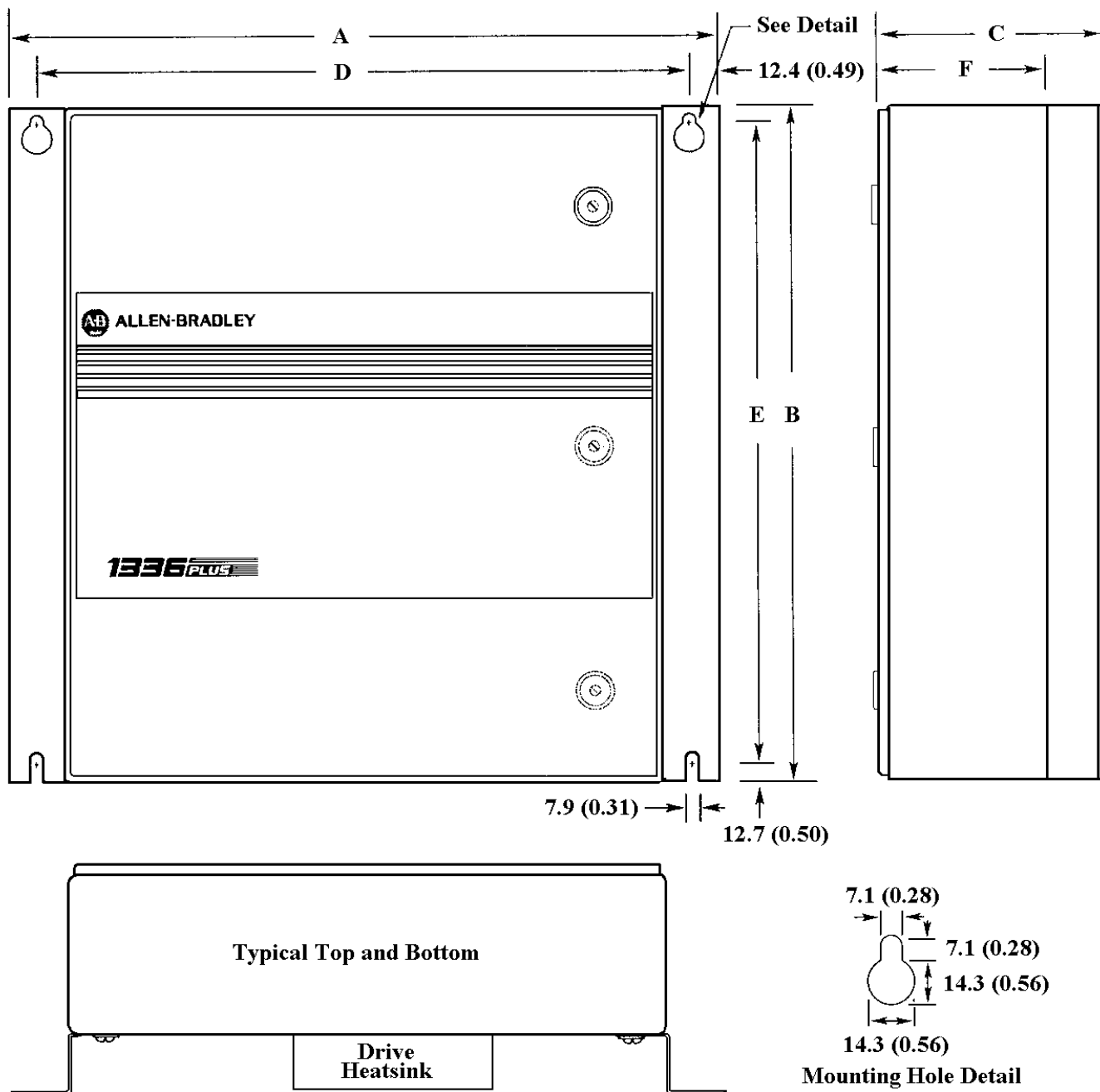
**Figure 2C.**  
**IP 20 (NEMA Type 1) Dimensions - Frame E**



All Dimensions in Millimeters and (Inches)  
 All Weights in Kilograms and (Pounds)

Frame Reference	A	B	C Max.	D	E	Y	Z	AA	BB	CC	Knockouts 3 - Dual Size, 6 - Fixed	Shipping Weight
E	511.0 (20.12)	1498.6 (59.00)	424.4 (16.71)	477.5 (18.80)	1447.8 (57.00)	16.8 (0.66)	40.1 (1.61)	157.5 (6.20)	860.6 (33.88)	81.3 (3.20)	92.1/104.8, 22.2 (3.625/4.125, 0.875)	186 kg (410 lbs.)

**Figure 2D.**  
**IP 65/54 (NEMA Type 4/12)**



All Dimensions in Millimeters and (Inches)  
 All Weights in Kilograms and (Pounds)

Frame Reference	A	B	C	D	E	F	Weights
<b>A1, A2, A3</b>	430.0 (16.93)	525.0 (20.67)	350.0 (13.78)	404.9 (15.94)	500.1 (19.69)	250.0 (9.84)	1
<b>B</b>	655.0 (25.79)	650.0 (25.59)	393.0 (15.47)	629.9 (24.80)	625.1 (24.61)	293.0 (11.54)	1
<b>C</b>	655.0 (25.79)	900.0 (35.43)	393.0 (15.47)	629.9 (24.80)	875.0 (34.45)	293.0 (11.54)	1

<sup>1</sup> Not available at time of Publication.