



ALLEN-BRADLEY BULLETIN 1336 PLUS PROCESS PI REGULATOR

APPLICATION NOTE #1336S - 16

July 1, 1997

PURPOSE

The integral Process PI regulator of the 1336 PLUS can provide PI control of a process without the addition of external PI controllers. The purpose of this document is to provide information and guidelines on the setup and operation of this PI loop.

WHAT THIS NOTE CONTAINS

This note will describe the function, setup and operation of the integral PI controller of the 1336 PLUS.

INTENDED AUDIENCE

This application note is intended to be used by personnel familiar with the hardware components and programming procedures necessary to operate the Bulletin 1336 PLUS.

WHERE IT IS USED

The diagrams, parameter settings, auxiliary hardware and/or installation recommendations in this application note are designed to address specific issues in many different applications. Some changes by the Users may be necessary to apply the concepts of this document to a specific application.

TERMS AND DEFINITIONS

PI - Proportional - Integral
PID - Proportional - Integral - Derivative

The internal PI function of the 1336 PLUS provides closed loop process control with proportional and integral control action. The function is designed to be used in applications that require simple control of a process without external control devices. The PI function allows the Drives microprocessor to follow a single process control loop.

The PI function reads a process variable input to the drive and compares it to a desired setpoint stored in the drive. The algorithm will then adjust the output of the PI regulator, changing drive output frequency to try and make the process variable equal the setpoint.

Proportional control (P) adjusts output based on size of the error (larger error = PROPORTIONALLY larger correction). If the error is doubled, then the output of the proportional control is doubled and, conversely, if the error is cut in half then the output of the proportional output will be cut in half. With proportional control there is always an error, so the feedback and the reference are never equal.

Integral control (I) adjusts the output based on the duration of the error. (The LONGER the error is present, the harder it tries to correct). The integral control by itself is a ramp

output correction. This type of control gives a smoothing effect to the output and will continue to integrate until zero error is achieved. By itself, integral control is slower than many applications require and therefore is combined with proportional control (**PI**).

Derivative Control (D) adjusts the output based on the rate of change of the error and , by itself, tends to be unstable. The faster that the error is changing, the larger change to the output. Derivative control is generally not required and, when it is used, is almost always combined with proportional and integral control (**PID**).

The PI function can perform a combination of proportional and integral control. It does not perform derivative control, however, the accel / decel control of the drive can be considered as providing derivative control.

Process functions will typically be one of two types.

Process Trim takes the output of PI regulator and sums it with a master speed reference to control the process. The example shown in Fig. #1 is a winder / unwinder application using a dancer pot to control a tension loop in the process.

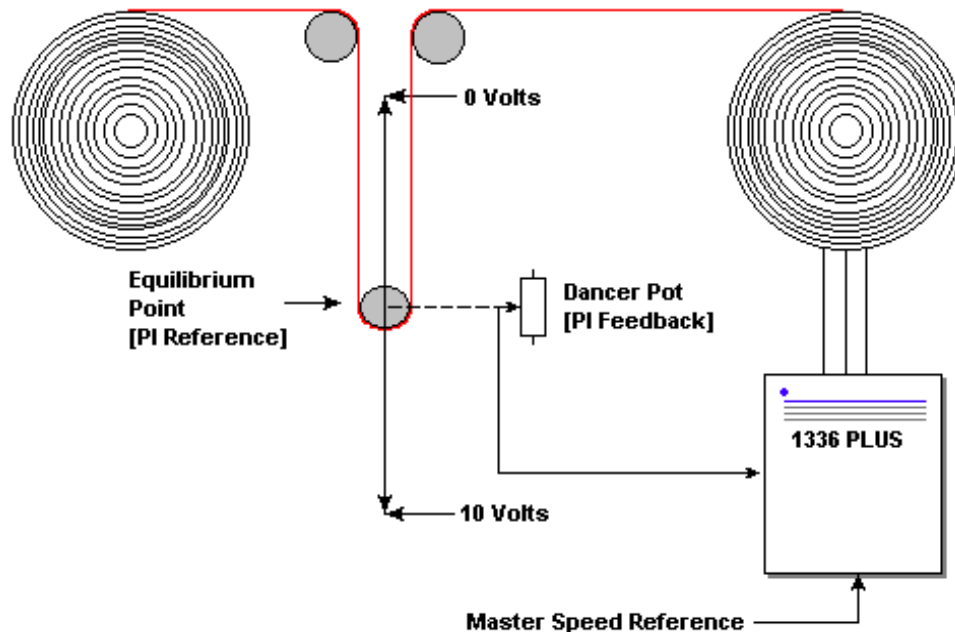

Figure 1

The master speed reference sets the wind / unwind speed and the dancer pot signal is used as a PI Feedback to control the tension in the system. An equilibrium point is programmed as PI Reference, and as the tension increases or decreases during winding, the master speed is trimmed to compensate and maintain tension near the equilibrium point.

Process Control takes the output of PI regulator as the speed command. No master speed reference exists and the PI Output directly controls the drive output. In the example shown in Figure #2, there is no master speed reference. By setting [Freq Select 1] to a value that cannot be used (Adapter # 3 if no adapter 3 is present) no master speed reference will be used.

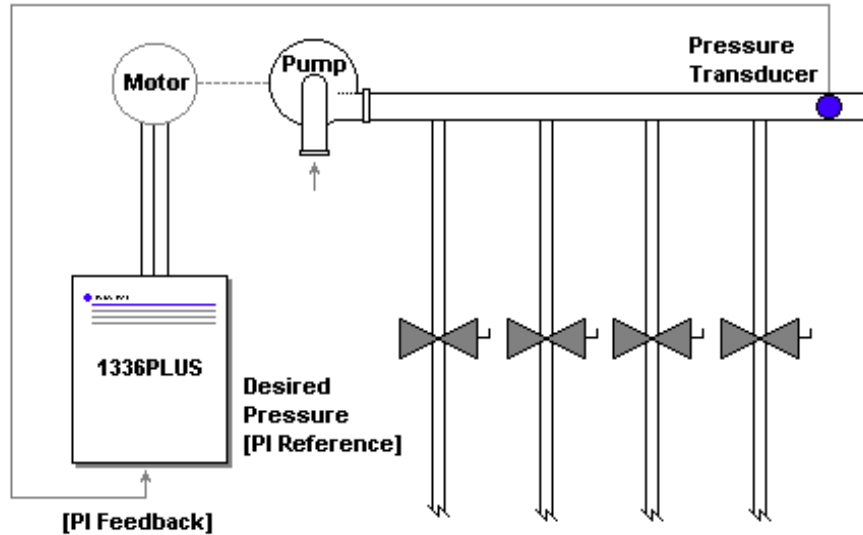

Figure 2

The input from the transducer is the PI Feedback and changes as the pressure changes. The drive output frequency is then increased or decreased as needed to maintain system pressure regardless of flow changes.

Operation and Setup

Selection

To operate the 1336 PLUS in PI regulator Mode, the speed regulation mode of the drive must be changed by selecting "Process PI" through the [Speed Control] parameter.

Configuration

The PI algorithm can then be adapted to a particular process control application by selecting the desired features and providing proper tuning. The features are chosen through the [PI Config] parameter, setting bits to activate each feature.

1. Invert Error

This feature changes the "sign" of the error, creating a decrease in output for increasing error and an increase in output for decreasing error. An example of this might be an HVAC system with thermostat control. In Summer, a rising thermostat reading commands an increase in drive output because cold air is being blown. In Winter, a falling thermostat commands an increase in drive output because warm air is being blown.

2. Reset Integrator

This feature holds the output of the integral function at zero. The term "anti windup" is often applied to similar features. It may be used for integrator preloading during transfer and can be used to hold the integrator at zero during "manual mode". Take the example of a process whose feedback signal is below the reference point, creating error. The drive will increase its output frequency in an attempt to bring the process into control. If, however, the increase in drive output does not zero the error, additional increases in output will be commanded. When the drive reaches programmed Maximum Frequency, it is possible that a significant amount of integral value has been "built up" (windup). This may cause undesirable and sudden operation if the system were switched to manual operation and back. Resetting the integrator eliminates this windup.

NOTE: In the 1336 PLUS, once the drive has reached the programmable Positive and Negative PI limits, the integrator stops integrating and no further "windup" is possible.

3. Zero Clamp

This feature limits the possible drive action to one direction only. Output from the drive will be from Zero to Maximum Frequency Forward or Zero to Maximum Frequency Reverse. This removes the chance of doing a “plugging” type operation as a radical attempt to bring the error to zero.

4. Square Root Feedback

This feature uses the square root of the feedback signal as the PI feedback. This is useful in processes that control pressure, since centrifugal fans and pumps vary pressure with the square of speed.

5. Set Output

This feature allows the PI Output to be preloaded at start for better response with well defined systems. Refer to diagram 3 below.

6. Preload Integrator

This feature allows the PI Output to be stepped to a preload value for better dynamic response when the PI Output is enabled. Refer to diagram 2 below.

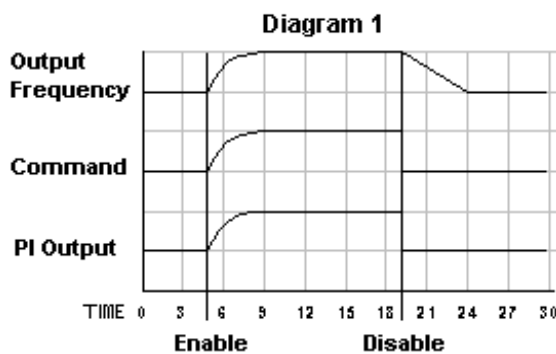

Preload and Set Output “OFF”

ENABLE - PI Output integrates from zero, drive ramps to regulated frequency.

DISABLE - PI Output is forced to zero, drive ramps to unregulated frequency.

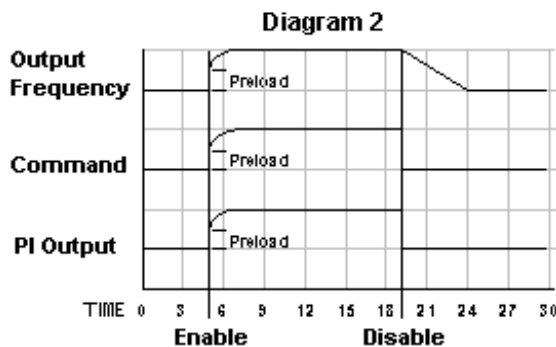

Preload Integrator “ON”

ENABLE - PI Output steps to preload and integrates from there, drive steps to preload and ramps to regulated frequency.

DISABLE - PI Output is forced to zero, drive ramps to unregulated frequency.

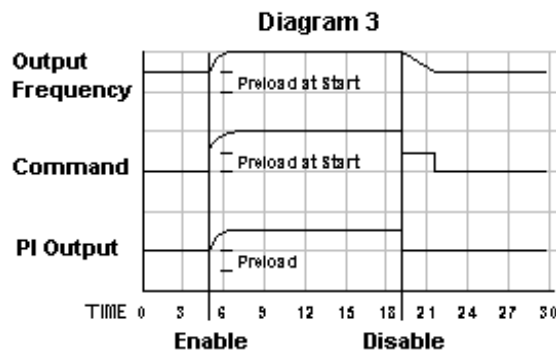

Set Output “ON”

ENABLE - PI Output integrates from preload, drive ramps from preload.

DISABLE - PI Output is held at preload, drive ramps to unregulated frequency (minimum preload).

Drive will step output equal to preload on start.

7. PI Enable

The PI regulator output can be turned on/off via the [PI Config] parameter, bit 4. Access to this on/off control is available by directly changing the bit in the parameter or by a logic input to TB3 when [Input Mode] is set to 22, 23, or 24.

PI Reference is the “set point” or the equilibrium value of the process. It can be programmed for any one of 17 sources .

Choices for adjustable source of setpoint are:

Adapters - 1 of 6 external communications ports (HIM, PLC, COMM Card)

Remote Pot

Analog Input - 0-10V, 4-20 mA

Pulse Input.

MOP Input

Choices for fixed value are Preset Frequencies 1 - 7.

(these become a setpoint reference and are not used as a speed command)

PI Feedback has the same choices as above. The feedback device itself will usually determine the input (0-10V, 4-20 mA) used for PI Feedback. It may, however, be routed through a PLC and transferred to the drive through an adapter. The PI function compares the desired setpoint (PI reference) to feedback (PI Feedback) producing error (PI Error).The Feedback is the actual condition of the process

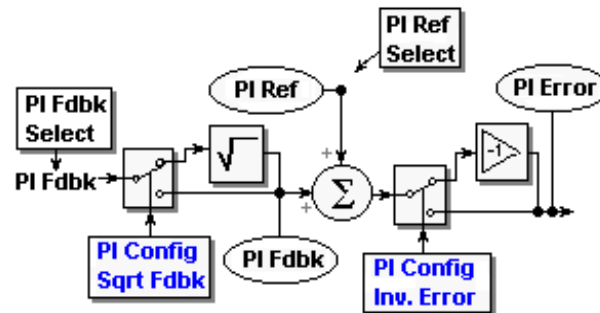

Figure 3

Setting PI Reference and PI Feedback

The setting of the PI Reference is determined by the feedback device, the analog input used, the Minimum and Maximum programmed drive frequencies and the square root function of the PI controller. The PI reference is programmed in Hertz.

Application Example

1. Drive Minimum Frequency = 0 Hz.
2. Drive Maximum Frequency = 60 Hz.
3. Preset 7 chosen as storage for PI Reference
4. Required pressure is 60 PSI
5. Transducer gives 0 - 10 Volt linear signal for 0 - 100 PSI

Parameter Settings

NUMBER	GROUP	PARAMETER	VALUE
77	Process PI	Speed Control	Process PI
213	Process PI	PI Config	00000000
215	Process PI	PI Ref Select	Preset 7
216	Process PI	PI Fdbk Select	0-10 Volt
16	Setup	Minimum Freq	0 Hz.
19	Setup	Maximum Freq.	60 Hz.

Determine the Transducer and Analog Input Gain for the system.

the Transducer gain: $G_t = \frac{10 \text{ Volts}}{100 \text{ PSI}}$

the analog input gain: $G_a = \frac{\text{MaxFreq} - \text{MinFreq}}{10 \text{ Volts}} = \frac{60 - 0}{10} = 6.00 \text{ Hz/Volt}$

Given the information above, the drive setting can be determined as follows:

PI Reference = Required Pressure * G_t * G_a + Minimum Freq

PI Reference = $60 \text{ PSI} * \frac{10 \text{ Volts}}{100 \text{ PSI}} * \frac{6 \text{ Hz}}{1 \text{ Volt}} + \text{Minimum Freq} = 36 \text{ Hz}$

This value is then programmed as the PI Reference (entered into Preset 7).

If the system changed pressure with the square of speed, the formula would change as follows:

Pi Reference = $\sqrt{[60 \text{ PSI} * \frac{10 \text{ Volts}}{100 \text{ PSI}} * \frac{6 \text{ Hz}}{1 \text{ Volt}} + \text{Minimum Freq}] * \text{Maximum Freq}} = 46.48$

This setup would produce the following outputs:

PSI	FDBK Volts	Drive output Hz.	
		without SQRT	with SQRT
0	0	0	0
10	1	6	18.97
20	2	12	26.83
30	3	18	32.86
40	4	24	37.95
50	5	30	42.43
60	6	36	46.48
70	7	42	50.20
80	8	48	53.67
90	9	54	56.92
100	10	60	60

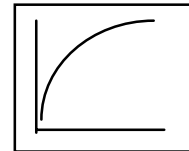
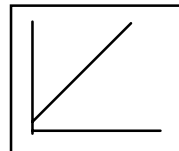

**Non Zero
Minimum Speed**

If the Minimum Frequency of the system was 30 Hz. , the values would change as follows:

the Transducer gain: $G_t = \frac{10 \text{ Volts}}{100 \text{ PSI}}$

the Analog Input gain: $G_a = \frac{\text{MaxFreq} - \text{MinFreq}}{10\text{Volts}} = \frac{60 - 30}{10} = 3.00\text{Hz} / \text{Volt}$

PI Reference = $60\text{PSI} * \frac{10\text{Volts}}{100\text{PSI}} * \frac{3\text{Hz}}{1\text{Volt}} + \text{Minimum Freq} = 48\text{Hz}$

If this system changed pressure with the square of speed, the formula would change as follows:

Pi Reference = $\sqrt{[60\text{PSI} * \frac{10\text{Volts}}{100\text{PSI}} * \frac{3\text{Hz}}{1\text{Volt}} + \text{Minimum Freq}] * \text{Maximum Freq}} = 53.66$

This setup would produce the following outputs:

PSI	FDBK Volts	Drive output Hz.	
		without SQR_RT	with SQR_RT
0	0	30	42.43
10	1	33	44.50
20	2	36	46.48
30	3	39	48.37
40	4	42	50.20
50	5	45	51.96
60	6	48	53.67
70	7	51	55.32
80	8	54	56.92
90	9	57	58.48
100	10	60	60.00

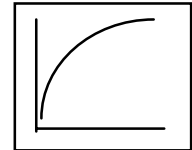
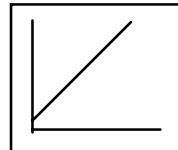

PI Output

The PI Error is then sent to the Proportional and Integral functions, which are summed together.

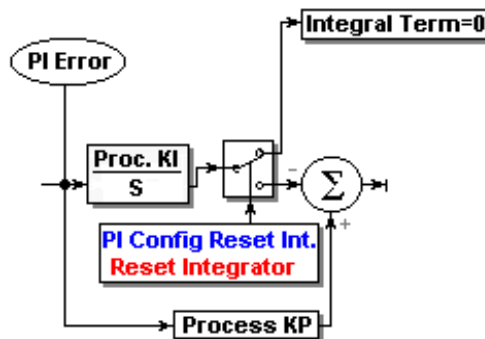

Figure 4

Kp Process

This parameter sets the **proportional gain** for the process control algorithm. Increasing this value will increase system sensitivity based on the size of the PI Error. Tuning of the system usually begins by increasing this value somewhat above the factory default and then moving to the Integral Gain.

Ki Process

This parameter sets the **integral gain** for the process control algorithm. Increasing this value will increase system sensitivity based on the duration of the PI Error. The longer an error exists, the higher the output of the integrator. Once the Kp value is set, increasing this value will bring the system to the desired response level. If this value is set too high, the system will become unstable, usually characterized by "hunting"; the output will overshoot the setpoint, then undershoot the setpoint in an over-reactive attempt to maintain setpoint. If the desired system performance cannot be reached after this adjustment, return to readjust the Kp gain, then repeat the process.

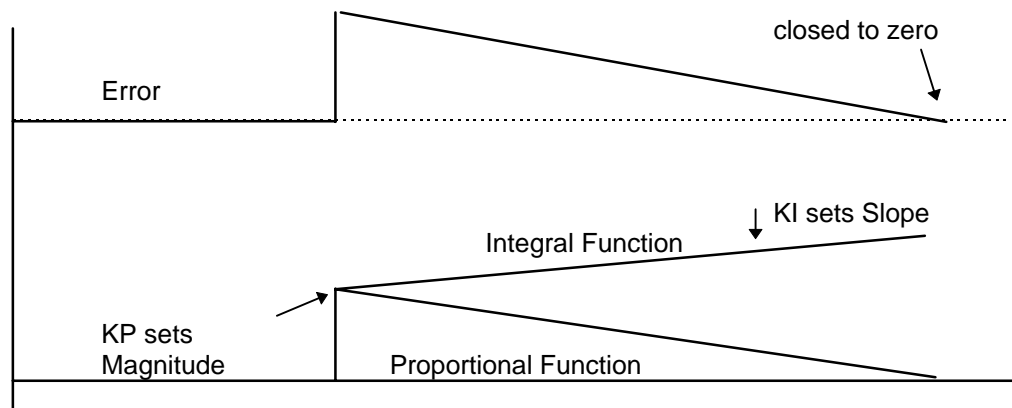

PI Negative Limit & PI Positive Limit

The results of the summing junction are then sent through a set of clamps or limits to produce the PI Output. The limits are programmable between zero and programmed Max. Frequency. There are separate limits for forward (PI Pos Limit) and Reverse (PI Neg Limit).

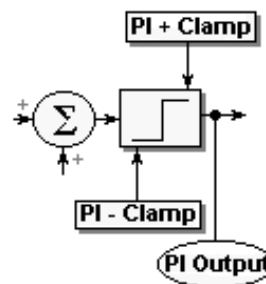

Figure 5

If the application is Process Control, typically these limits would be set to the maximum allowable frequency setting. This allows the PI regulator to control over the entire required speed range.

If the application is Process Trim, large trim corrections may not be desirable and the limits would be programmed for smaller values.

Zero Clamp

The output of the PI regulator is a speed adder to the master speed reference. Once the two are summed, the are passed through the normal Max. Frequency limiting to a feature known as PI zero clamp.

When activated, this feature imposes another limit to make the output frequency mono-directional. The drive output is limited to one direction only so that no direction change is possible. This will prevent a plugging type operation to correct for larger error buildup in the PI loop.

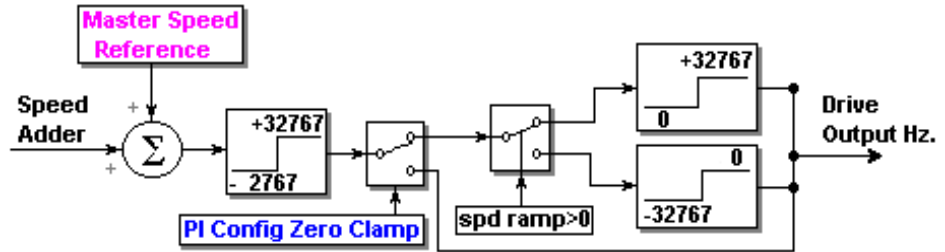

Figure 6

Process PI Block Diagram

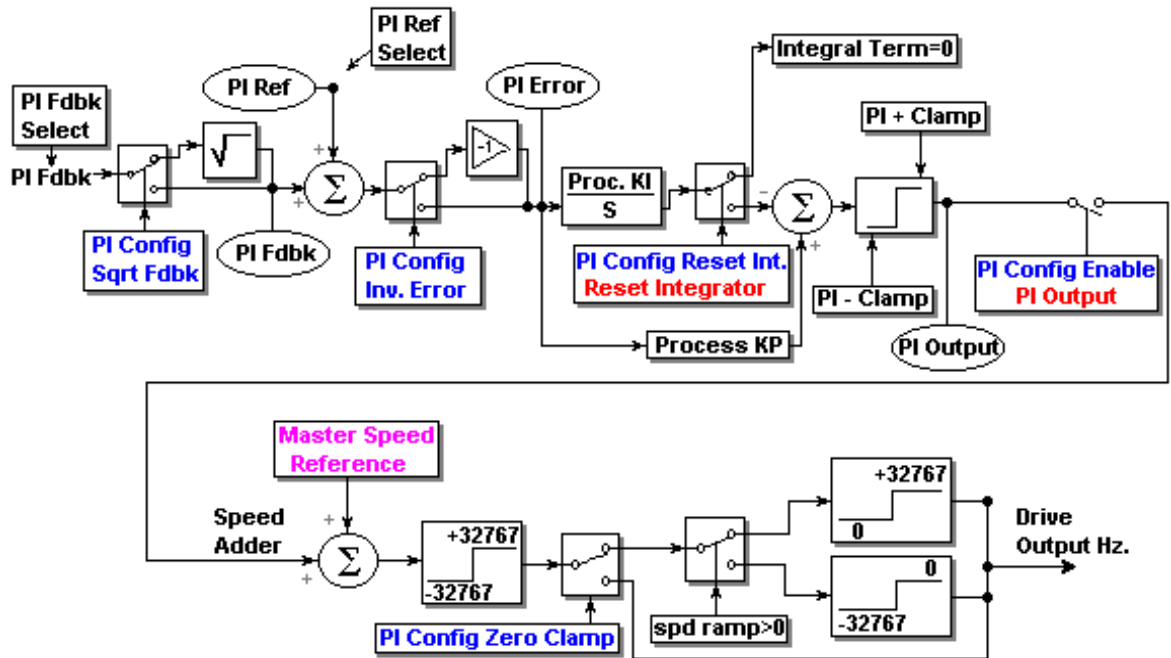
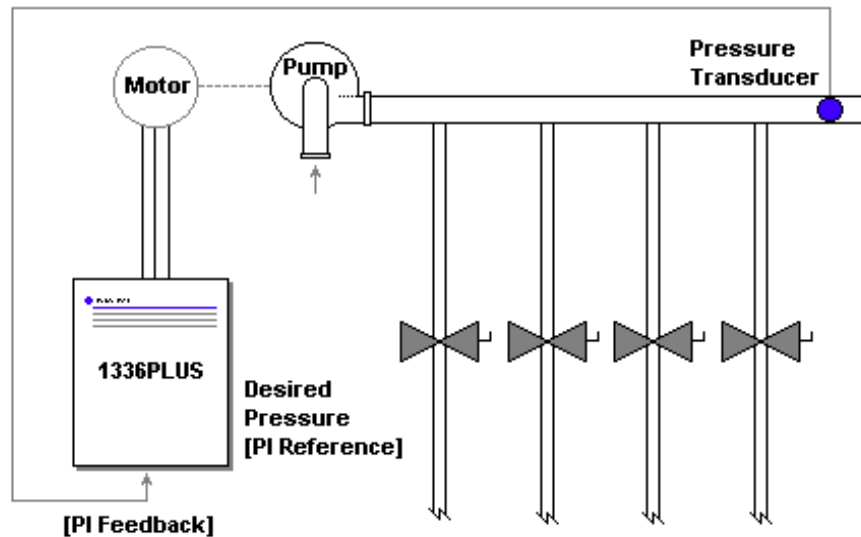

Figure 7

Typical Applications

In the pumping application example below, the reference or setpoint is the required pressure in the system. With the drive turning the pump at a certain speed, the required pressure is maintained in the system. The controlled process will always have zero error.



However, when additional valves in the system are opened, the pressure in the system will drop. The pressure transducer signal to the drive (PI Feedback) changes accordingly. This signal is constantly compared to the PI Reference and a PI Error is produced (the difference between the setpoint and the variable feedback is the error signal; $PI\ Error = PI\ Ref - PI\ Fdbk$). This Error is then used in conjunction with proportional and integral gains to alter the PI output. The drive will then alter its output frequency in an attempt to bring the process back into control (zero error).