



10409 MEECH AVE. CLEVELAND OHIO 44105 AREA CODE 216-641-8310

Pulse Generator Instructions

M785

Description

The Model M785 Pulse Generator is a zero-speed rotary transducer, allowing operation down to zero RPM. The M785 generates a specific number of pulses for each rotation of its shaft. When coupled to a machine, its output is directly proportional to process travel (pulse count) or speed (pulse rate). The output signal is generated by a large, non-breakable disc rotating between an infrared source and four photo receptors. A rugged cast aluminum housing, steel shaft, and heavy-duty sealed bearings provide mechanical ruggedness required for industrial applications.

The M785's second output is electrically independent and totally isolated. For many applications, this feature provides a running spare by simply interchanging output connectors.

Installation

The pulse generator must be driven by a positive drive rather than a friction drive. The following means of coupling are acceptable when properly installed: Direct Coupling, Timing Belt/Pulleys, Chain/Sprockets.

If a direct drive is used, use a flexible coupling and align the shafts as accurately as possible. The pulse generator should not be subjected to any axial thrust. Overhung loads should also be minimized. Installations using timing belts/pulleys should have just enough belt tension to eliminate belt sag. Excessive tension will shorten belt and bearing service life. If a rubber slinger disc is used, position it on the shaft so it will rotate freely.

Caution

Do not force or drive the coupling onto the shaft, or damage to the bearings may result. The coupling should slide easily on the shaft and not be stretched or compressed.

For more details and special considerations in specifying and installing drive components, refer to separate installation instructions, Avtron Rotary Pulse Generators.

Caution

DO NOT force or drive a coupling onto the shaft. This can damage bearings so that a failure will happen at a later time.

DO NOT open an M785. This will void the warranty.

REPAIR of defective units requires returning the unit to the factory, where there is special test equipment. Turn-around time is minimal, and charges are nominal for out-of-warranty units.

DO NOT install M785's (or any other rotating equipment) where liquids will be sprayed or hosed onto them. If necessary, provide a shield.

DO NOT connect grounded oscilloscopes, K761, or any grounded instrument to M785 output.

DO NOT connect oscilloscope or any instrument common to any pulse generator connection other than common.

Various M785 options and how they are shown in the M785 part number are shown below:

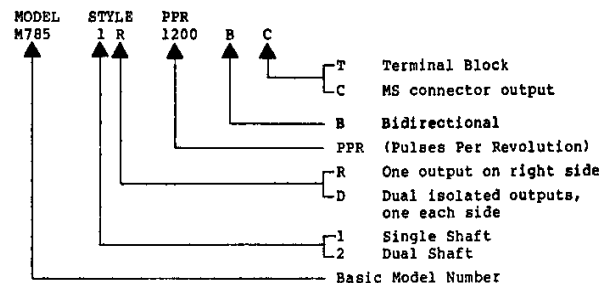

Special Application Notes

For bidirectional operation of the two-phase M785, proper phasing of the two output channels is important. Phase A channel leads phase B for clockwise rotation of the shaft as viewed from the end of the housing with the end plate (anti-drive end on units with single shaft extension).

Interconnection cables specified in the wiring diagrams are based on typical applications. Refer to the system drawing for specific cable requirements where applicable.

Physical properties of cable such as abrasion, temperature, tensile strength, solvents, etc., are dictated by the specific application. General electrical requirements are: stranded copper, 22 thru 16 gage, braid or foil with drain wire, 0.05 MF maximum total mutual or direct capacitance, outer sheath insulator, 1,000 ft. max.

Specifications

| | |
|------------------------------------|---|
| Operating Power (each output) | 12 to 15 VDC at approx. 125 mA |
| Output Signal | Two channels in quadrature (two-phase, bidirectional) |
| Pulses Per Revolution | 600, 1024, 1200 PPR standard - Others available upon request |
| Wave Shape | Square Wave |
| Voltage Output | High: Supply Voltage - 1 Volt (No Load) 120 Ohms Pull-up Low: 1.0 V Max 50 mA Sink |
| Frequency | 50 KHz Max |
| Output Protection | Short Circuit Protection to Common |
| Speed Range | 0 to 3000 RPM |
| Operating Temperature | 0° to 160°F ambient |
| Weight | 15 lbs. (Style 2D) |
| Mechanical | |
| Starting Torque | 2.2 oz. - in. (typ.) |
| Shaft Inertia | 0.1 oz. - in. - sec ² |
| Acceleration (max.) | 5,000 RPM/sec. |

Wiring Diagram

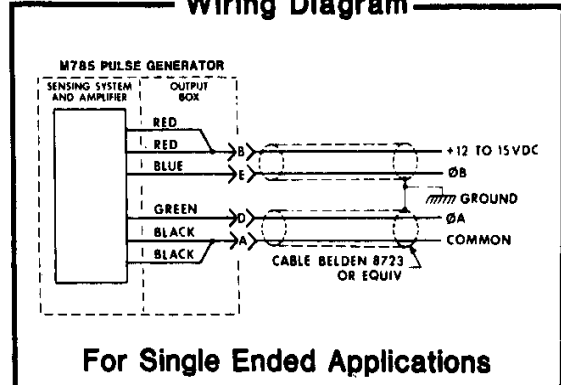

Wiring Diagram

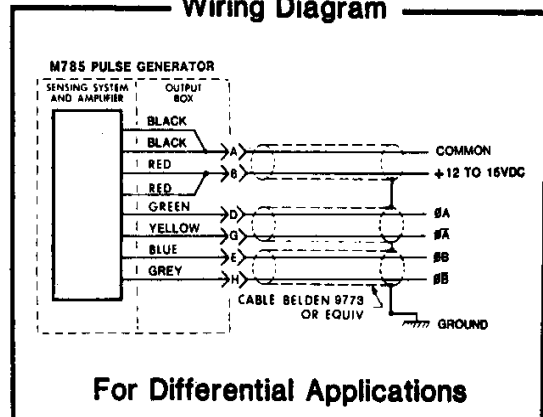

Outline Drawing

