

1 2 3 4 5 6 7 8

A
B
C
D
E
F
G
H

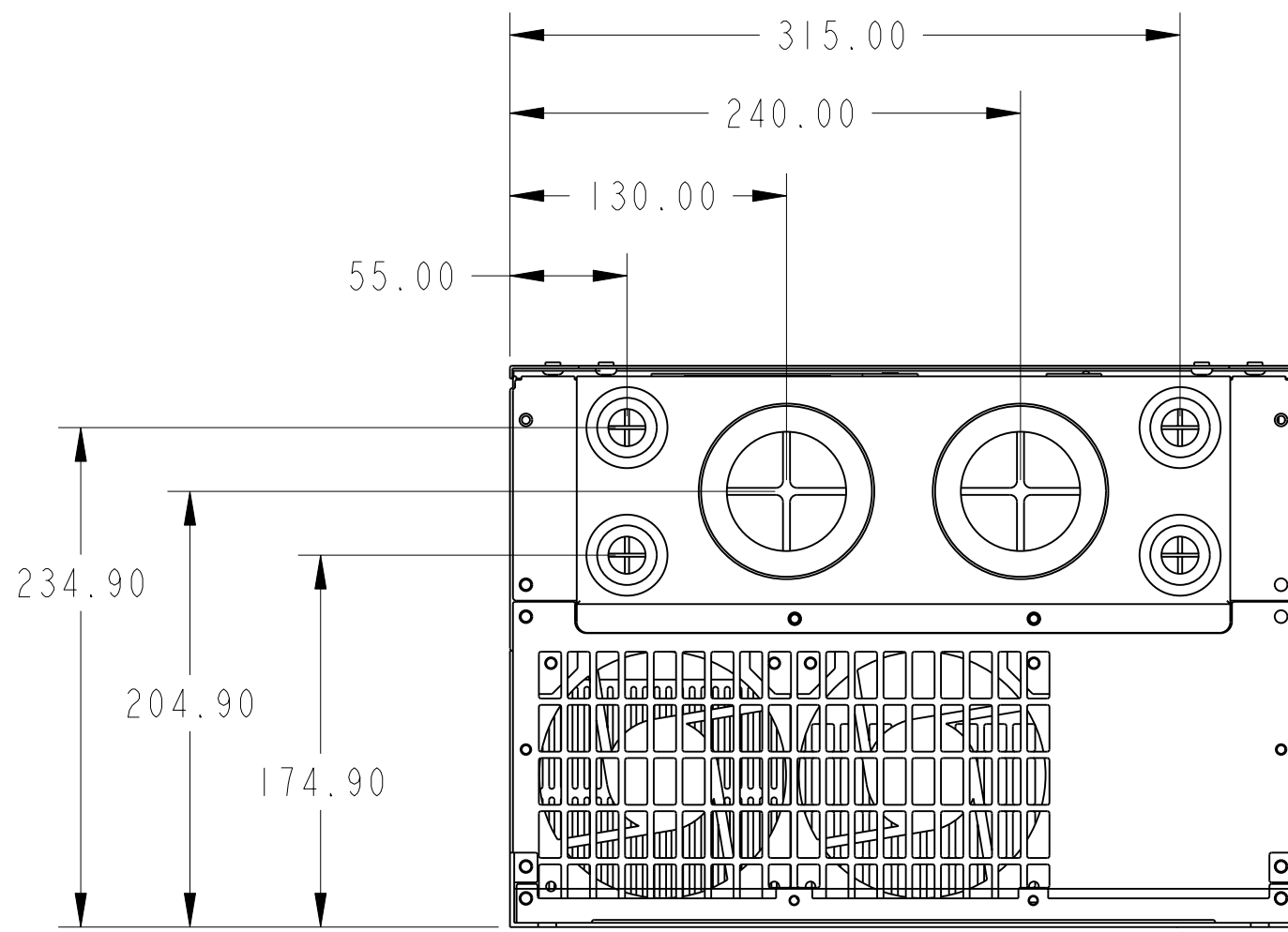
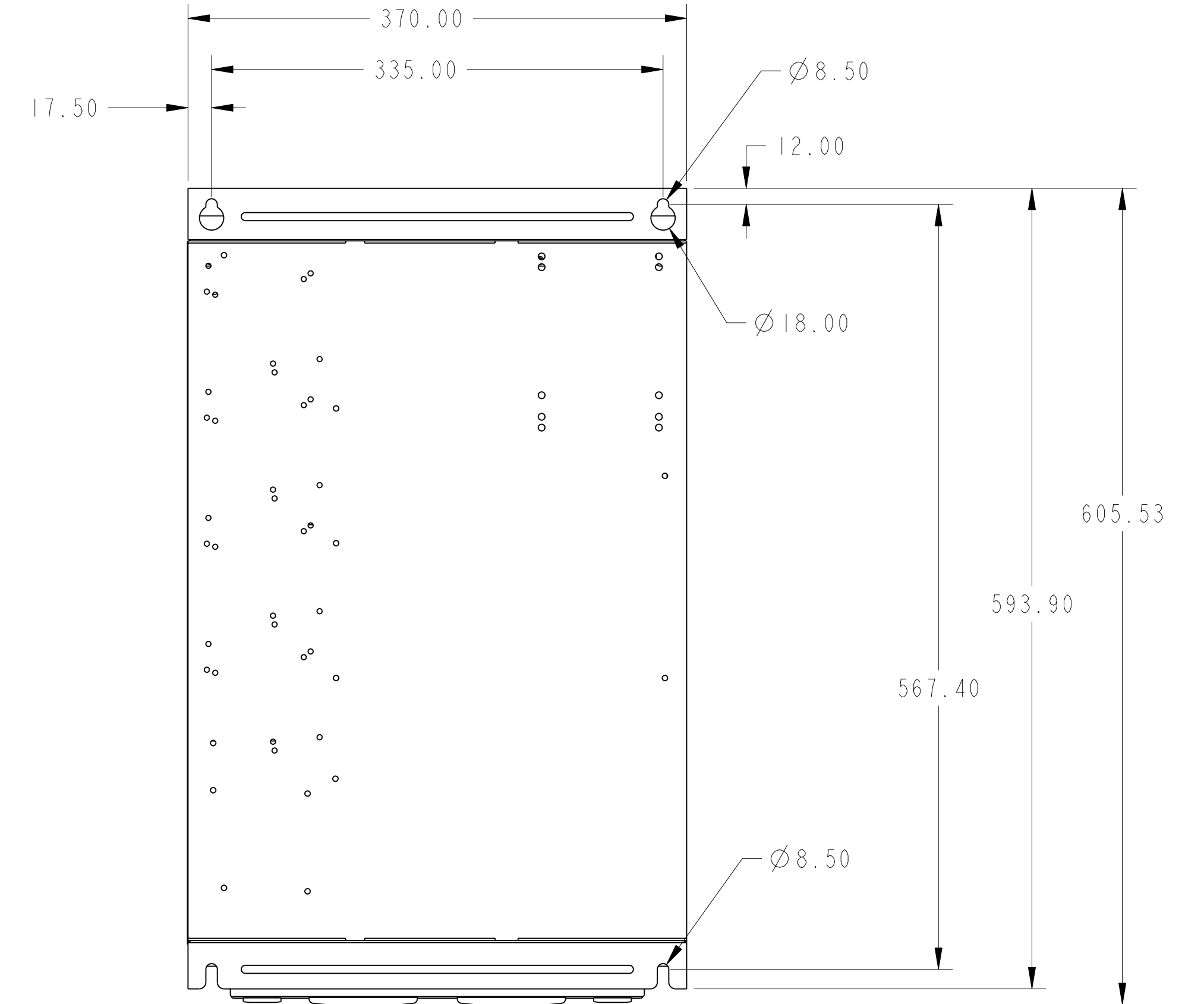
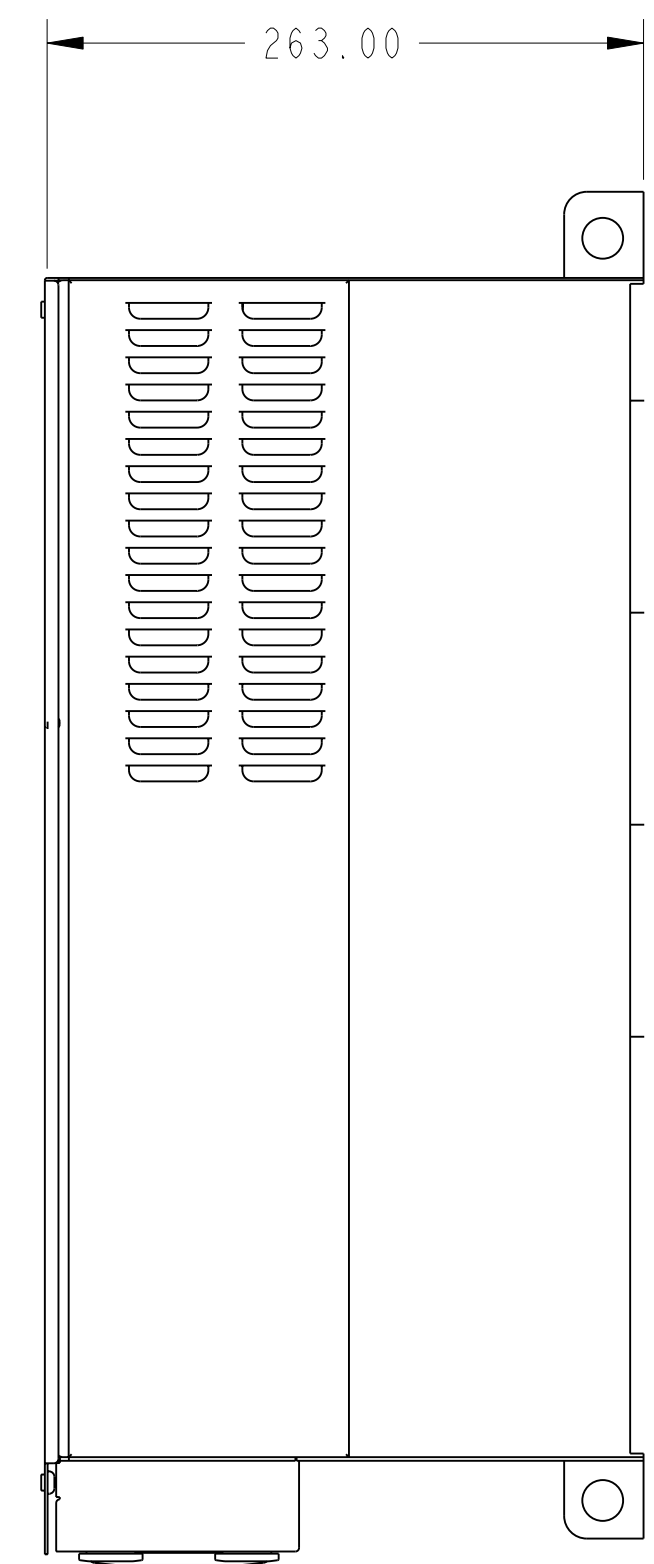
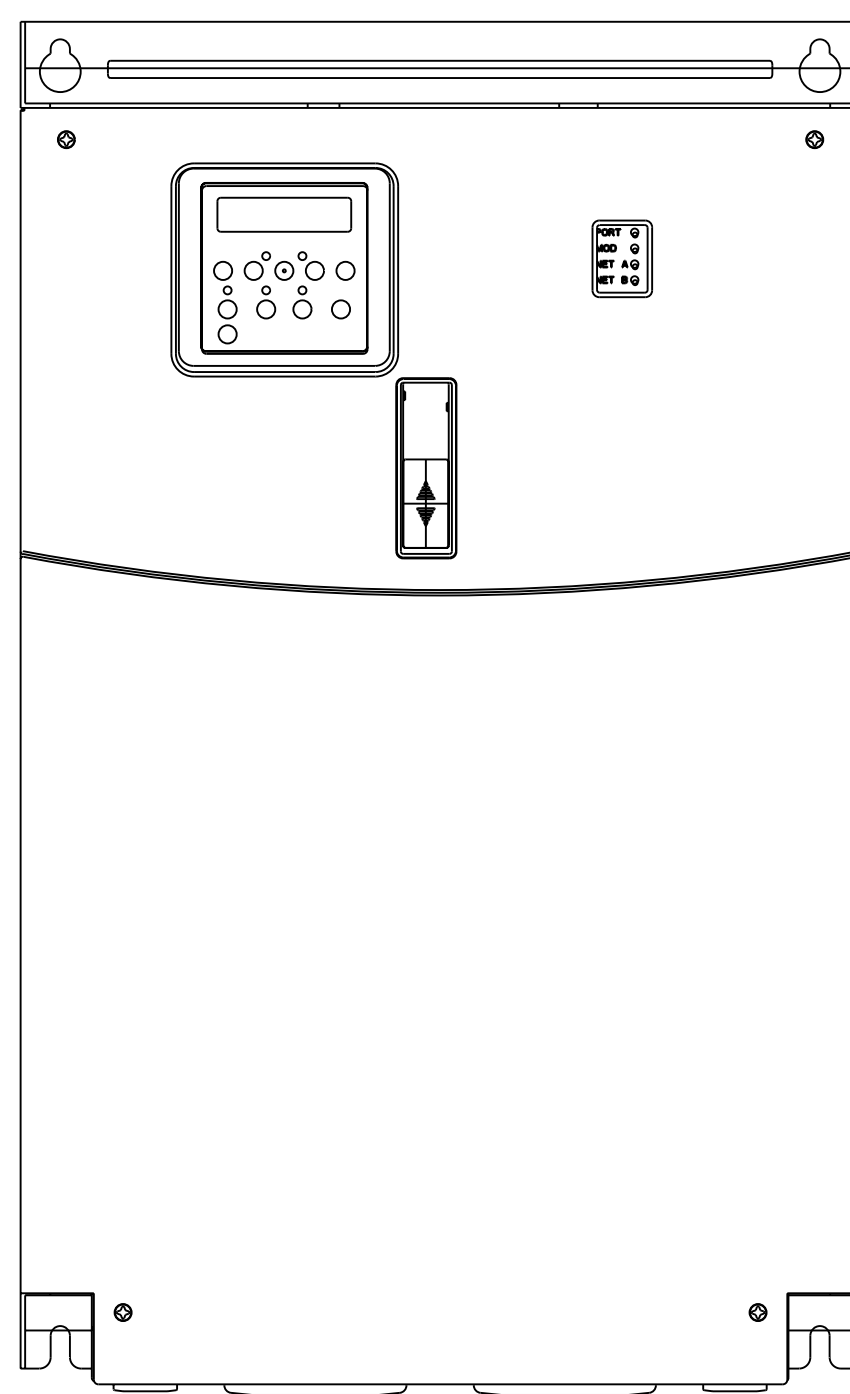
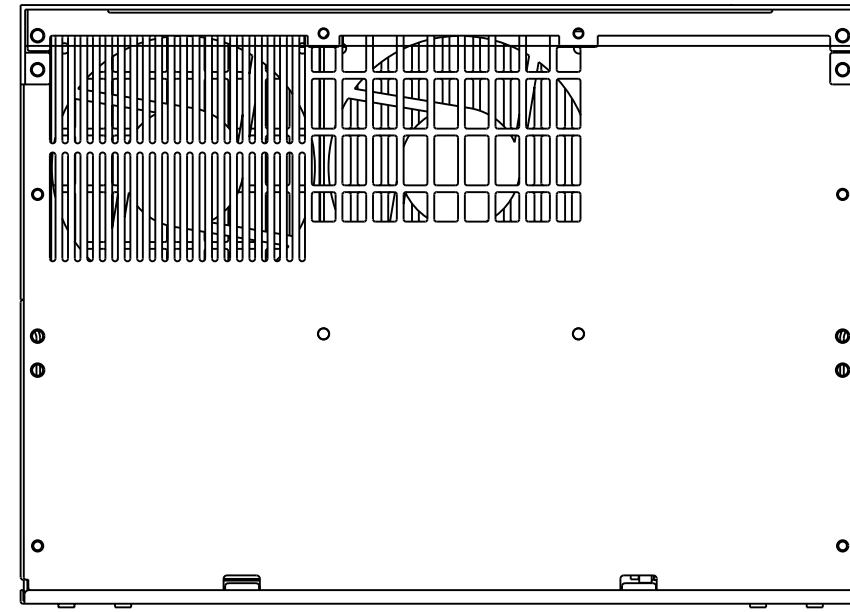

SCALE: 0.30 = 1.00

PARTS MUST CONFORM TO APPLICABLE ROCKWELL AUTOMATION MANUFACTURING STANDARDS
CAD DOCUMENT
 FILE NAME: PF400_EFRAME_OUTLINE

| | | | | |
|------------------------|--|--------------------------------|-----------|---|
| REFERENCES | | PF400, FRAME E OUTLINE DRAWING | | THIS DRAWING IS THE PROPERTY OF ROCKWELL AUTOMATION, INC. OR ITS SUBSIDIARIES AND MAY NOT BE COPIED, USED OR DISCLOSED FOR ANY PURPOSE EXCEPT AS AUTHORIZED IN WRITING BY ROCKWELL AUTOMATION, INC. |
| REVISION AUTHORIZATION | DIMENSIONS APPLY BEFORE SURFACE TREATMENT DIMENSIONS IN MILLIMETERS | Rockwell Automation | | |
| | TOLERANCES UNLESS OTHERWISE SPECIFIED | DR. | SHERBINOW | DATE |
| | .X:± N/A | DATE | 10-07-04 | SHEET 1 OF 1 |
| | .XX:± N/A | CHKD. | DATE | DWG. SIZE |
| | ANGLES:± N/A | APPD. | DATE | D |
| 1 | 10/7/04 | | | PF400 E. OUTLINE |