

1 2 3 4 5 6 7 8

CLASSIFICATION TABLE						
P=PERFORMANCE, F=FIT, A=ASSEMBLY (USE ONLY WITH Ø SYMBOL) X=IDENTIFIES APPLICABLE CLASSIFICATION(S) Ø=REQUIRED BY ENGINEERING AND/OR MANUFACTURING ⊕=STRICT CONFORMANCE TO SPECIFICATION REQUIRED AND IS NOT NEGOTIABLE (MAY BE REQUIRED BY REGULATORY AGENCY)						
CHARACTERISTIC -OR- DIMENSION	COMMENT	DRAWING LOCATION (ZONE)	P	F	A	R

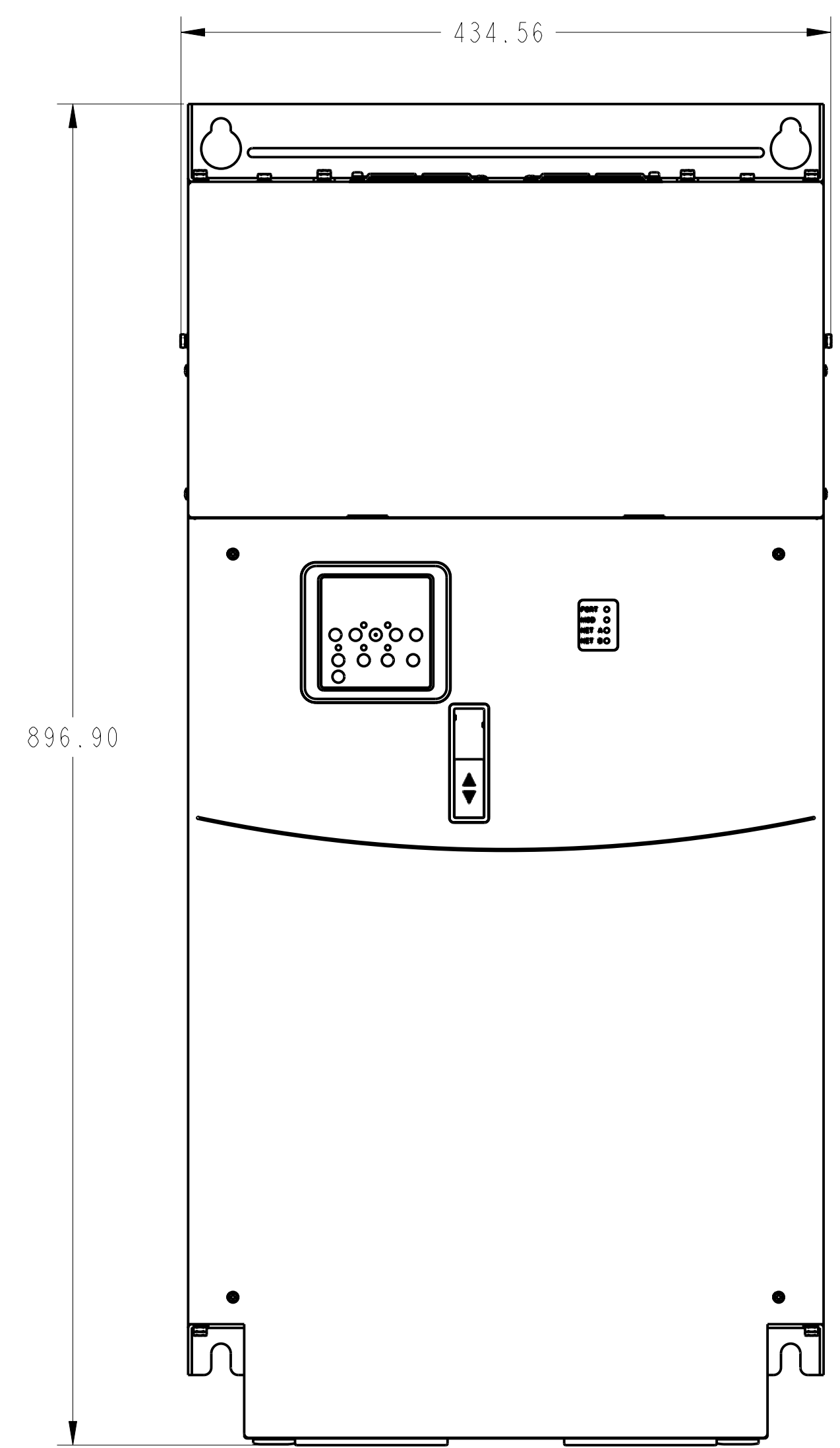

SCALE 0.300

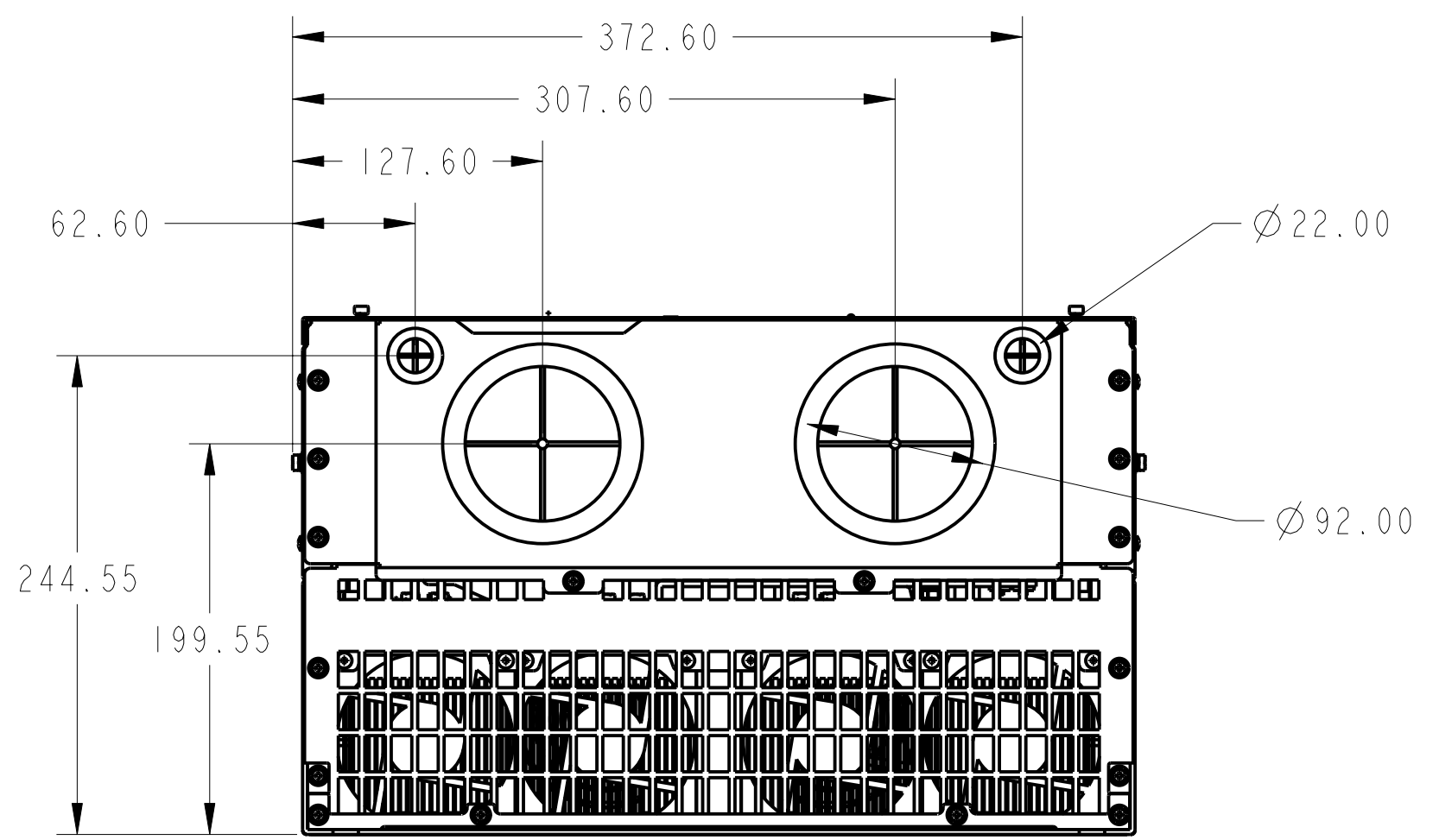
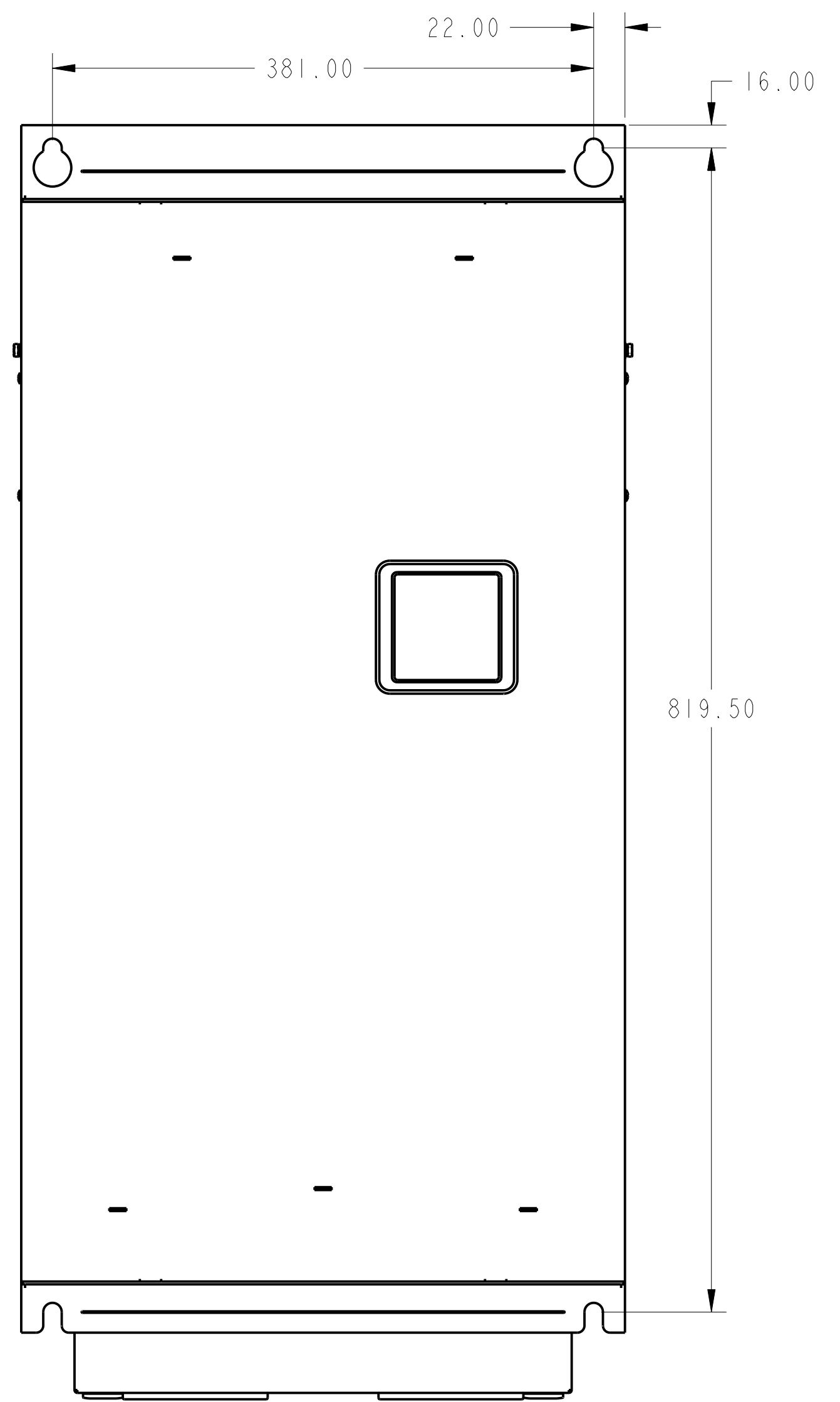
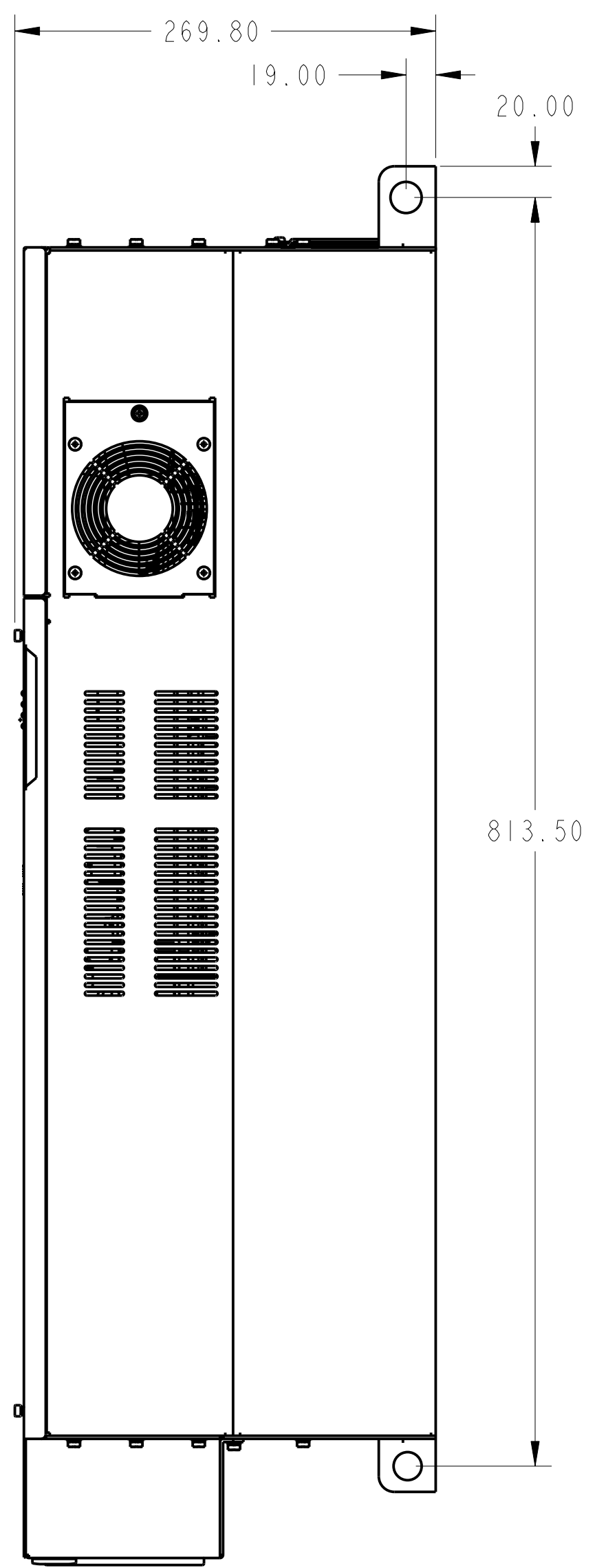

PARTS MUST CONFORM TO APPLICABLE ROCKWELL AUTOMATION MANUFACTURING STANDARDS
CAD DOCUMENT
FILE NAME 1195254

REFERENCES		DIMENSIONS APPLY BEFORE SURFACE TREATMENT		PF400 G OUTLINE		CONFIDENTIAL AND PROPRIETARY INFORMATION	
REVISION	AUTHORIZATION	DIMENSIONS IN MILLIMETERS		THIS DOCUMENT CONTAINS CONFIDENTIAL AND PROPRIETARY INFORMATION OF ROCKWELL AUTOMATION, INC. AND MAY NOT BE USED, COPIED OR DISCLOSED TO OTHERS, EXCEPT WITH THE AUTHORIZED WRITTEN PERMISSION OF ROCKWELL AUTOMATION, INC.			
		TOLERANCES UNLESS OTHERWISE SPECIFIED		Rockwell Automation			
		.X:±		DR.	CDS	DATE	05-23-07
		.XX:±		CHKD.		DATE	
		ANGLES:±		APPD.		DATE	
02	06/06/07						
01	05/24/07						

SHEET 1 OF 1
DWG SIZE 1195254