

Hardware Enable Circuitry (Enhanced Control Only)

By default, the user can program a digital input as an Enable input. The status of this input is interpreted by drive software. If the application requires the drive to be disabled without software interpretation, a hardware enable configuration can be utilized. This is done by removing the enable jumper (ENBL JMP) and wiring the enable input to “Digital In 6” (see below).

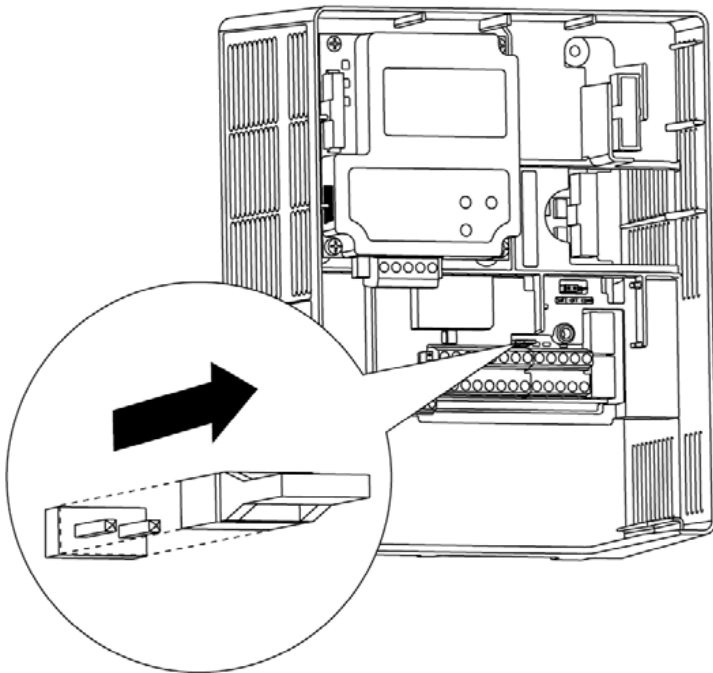

1. Remove drive cover.
2. Locate and remove the Enable Jumper on the Main Control Board (see diagram).
3. Wire Enable to “Digital In 6”
4. Verify that 366 [Digital In6 Sel] is set to option 1 “Enable”.

2 Wire Run FWD/REV, Enable, AUX Fault, Clear Fault User Supplied 24 volt Logic power – Powerflex 70 EC

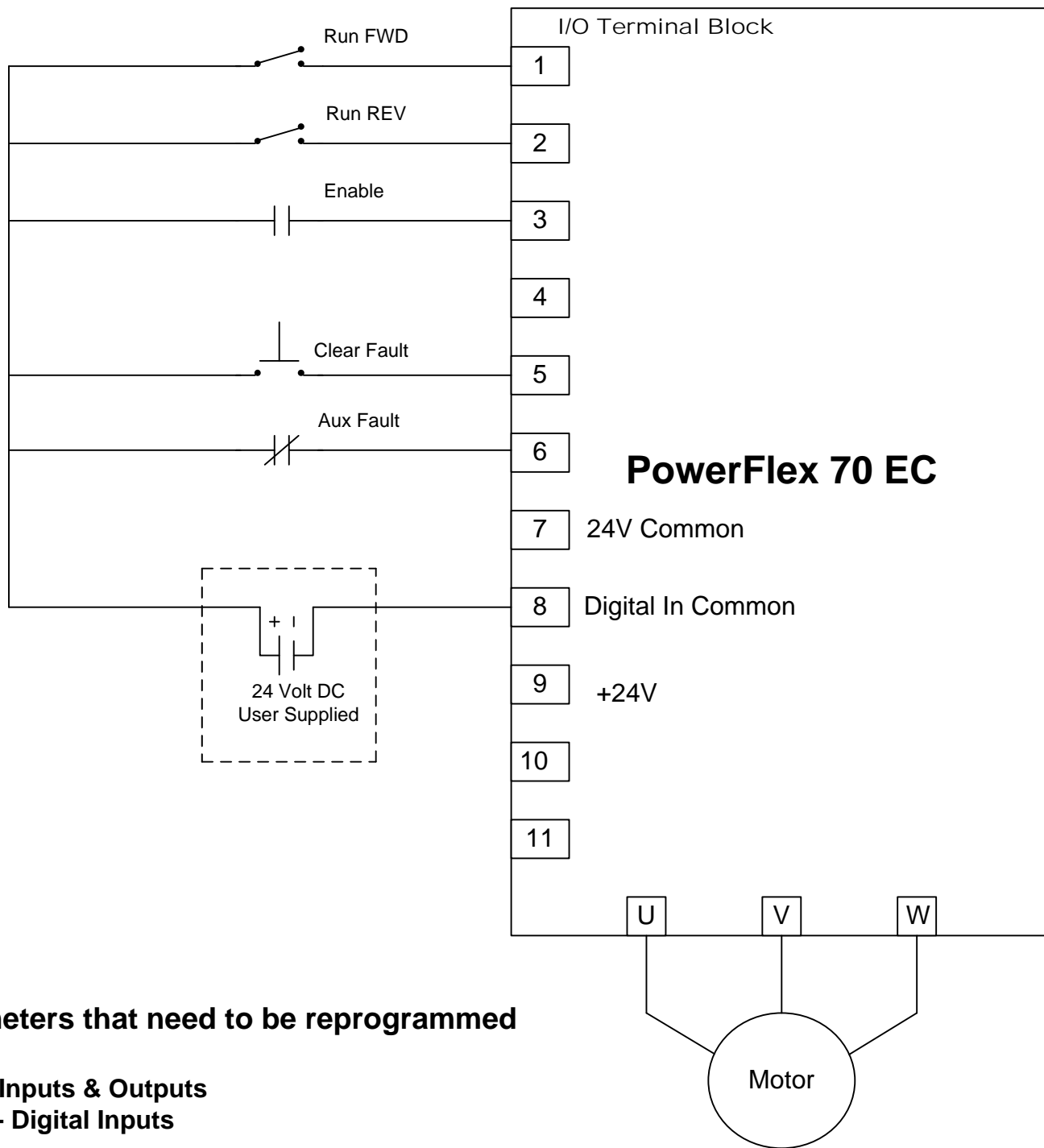

Parameters that need to be reprogrammed

File J / Inputs & Outputs Group - Digital Inputs

- 361 (Digital In1 Sel) = 8
- 362 (Digital In2 Sel) = 9
- 364 (Digital In4 Sel) = 3
- 365 (Digital In5 Sel) = 2
- 366 (Digital In6 Sel) = 1