

# Auto/Manual Application Drive Supply 24 volt Logic power

**Note:**

Auto = Speed reference from DPI Port 1 (**HIM**)

Manual = Speed reference from Speed Pot

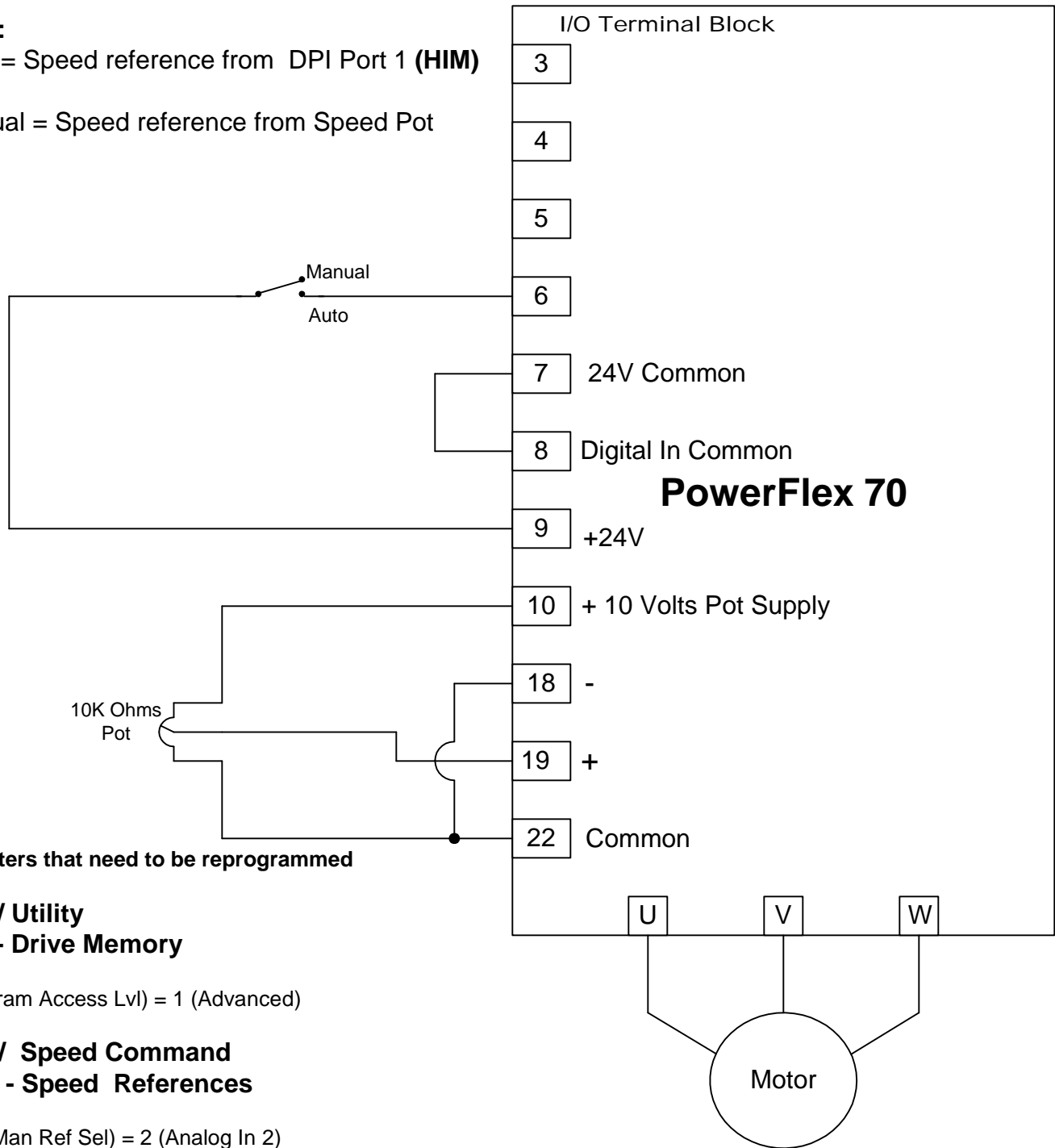

**Parameters that need to be reprogrammed**

**File E / Utility  
Group - Drive Memory**

196 (Param Access Lvl) = 1 (Advanced)

**File C / Speed Command  
Group - Speed References**

96 (TB Man Ref Sel) = 2 (Analog In 2)  
90 (Speed Ref A Sel) = 18 (DPI Port 1)

**File C / Speed Command  
Group - Speed Trim**

117 (Trim In Select) = 20 (DPI Port 3)

**File C / Speed Command  
Group - Process PI**

128 (PI Feedback Sel) = 20 (DPI Port 3)

**File J / Inputs & Outputs  
Group - Digital Inputs**

366 (Digital In6 Sel) = 18 (Auto/Manual)