

# Speed Pot Connections and Programming

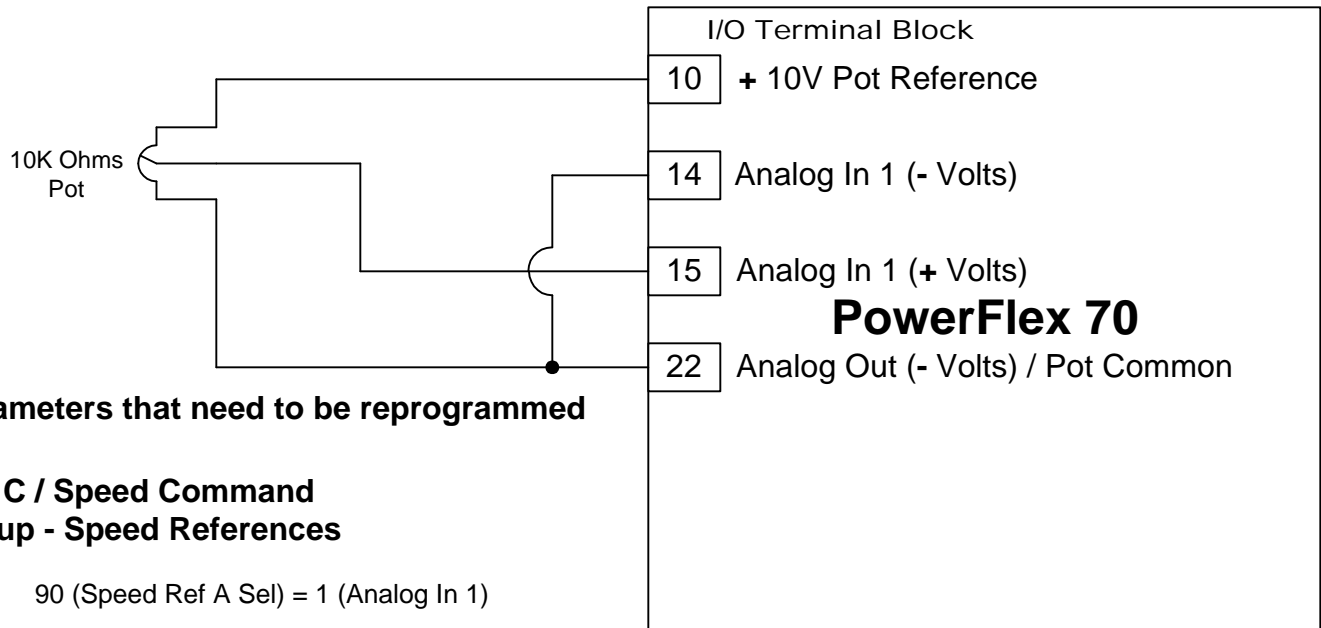

## Parameters that need to be reprogrammed

### File C / Speed Command Group - Speed References

90 (Speed Ref A Sel) = 1 (Analog In 1)

### File J / Inputs & Outputs Group - Analog Inputs

320 (Anlg In Config) = Nibble 1 = XX00

Or

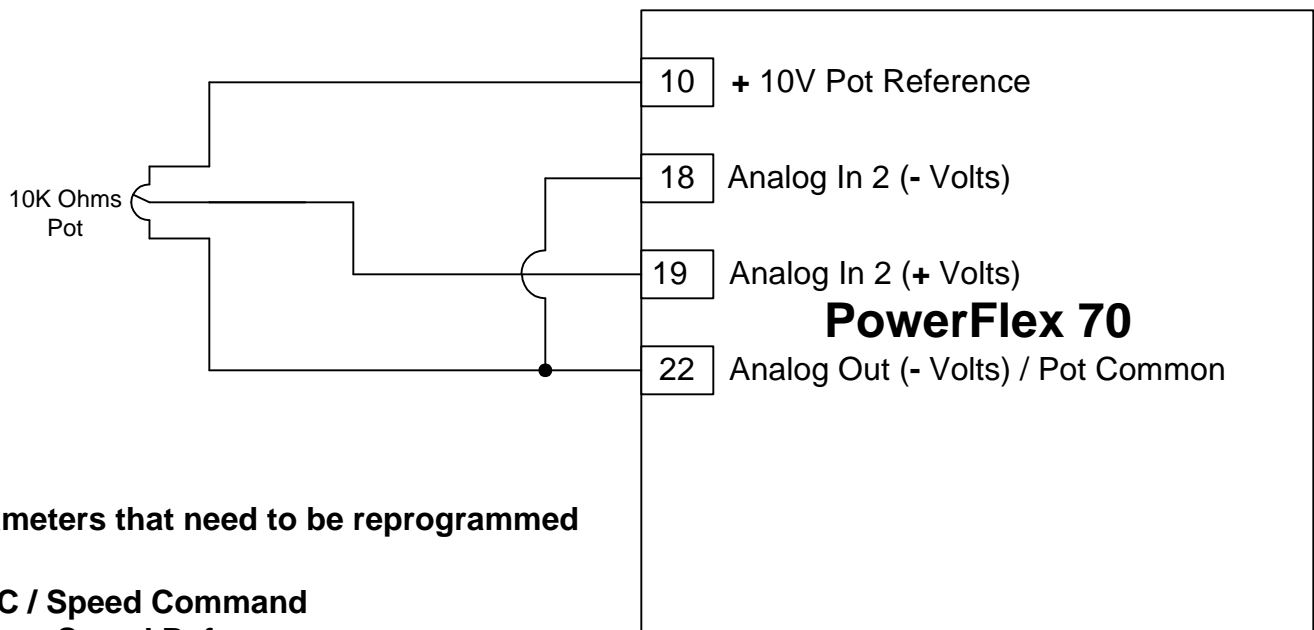

## Parameters that need to be reprogrammed

### File C / Speed Command Group - Speed References

90 (Speed Ref A Sel) = 2 (Analog In 2)

### File J / Inputs & Outputs Group - Analog Inputs

320 (Anlg In Config) = Nibble 1 = XX00