

Speed Trim Application

Speed Command from DPI Port 1 (HIM) with Trim from Pot

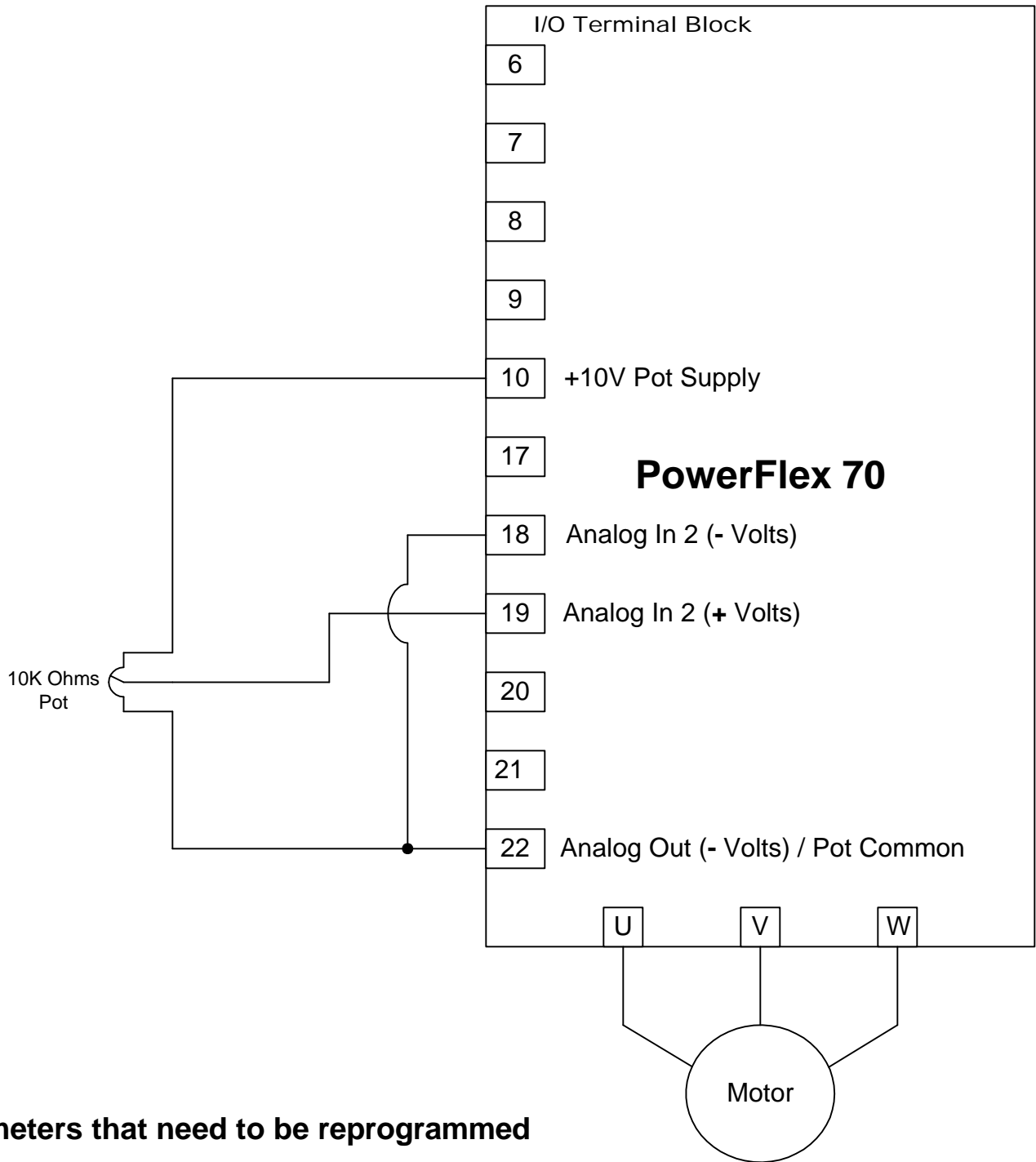

Parameters that need to be reprogrammed

File E / Utility
Goup - Drive Memory

196 (Param Access Lvl) = 1 (Advanced)

File C / Speed Command
Group - Speed References

90 (Speed Ref A Sel) = 18 (DPI Port 1)

File C / Speed Command
Group - Speed Trim

117 (Trim In Select) = 2 (Analog In 2)

118 (Trim Out Sel) = Nibble 1 = XX01

Modify 119 (Trim Hi) and 120 (Trim Lo) For Trim span.