

Selecting 3 Different Speed Command Sources 0 to Volts, Preset 1 = 10 Hertz, Preset 2 = 30 Hertz

Speed Sel 1 = Open
Speed Sel 2 = Open = Speed Source is 0 to 10 Volts

Speed Sel 1 = Closed
Speed Sel 2 = Open = Speed Source is Preset 1

Speed Sel 1 = Open
Speed Sel 2 = Closed = Speed Source is Preset 2

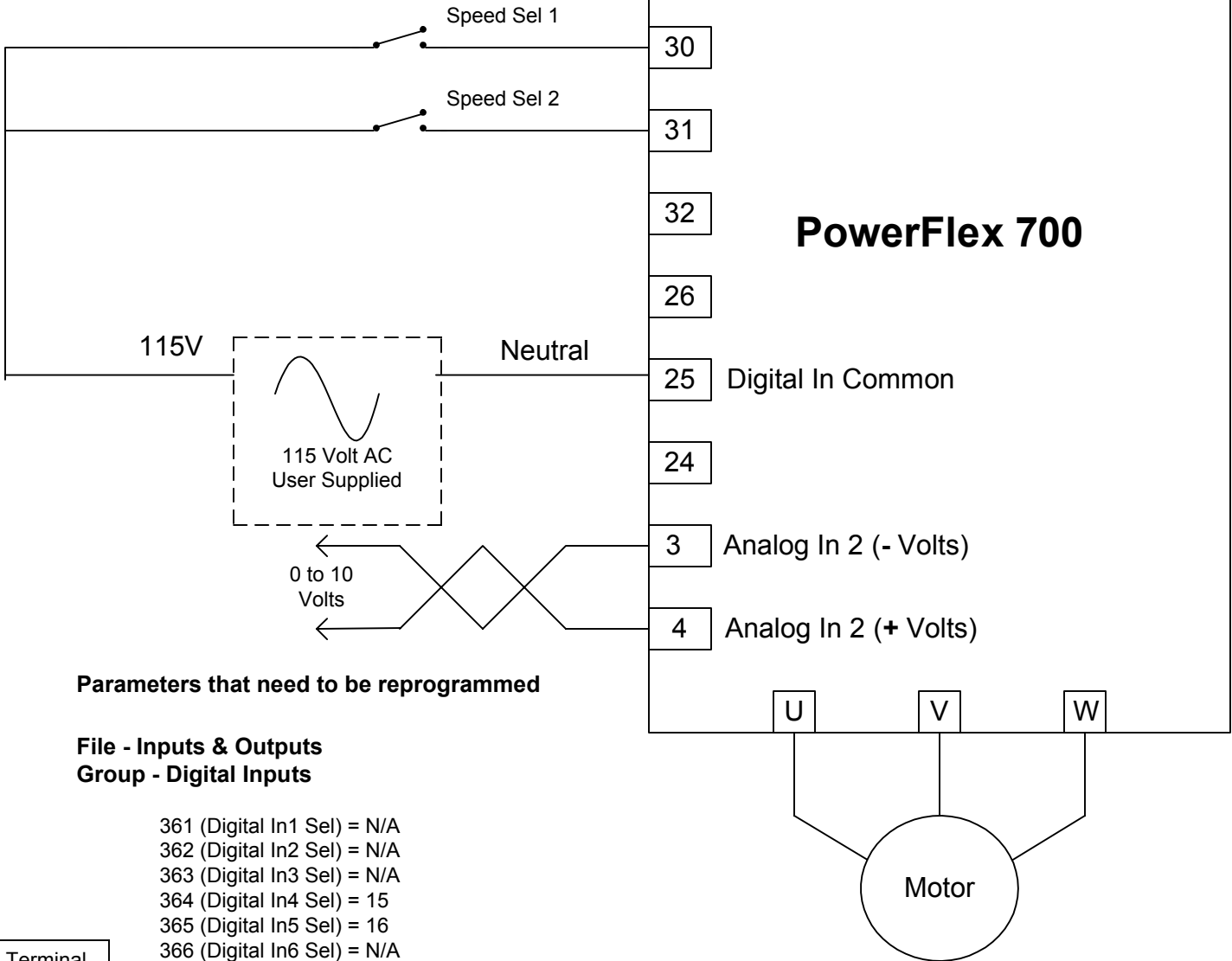

Parameters that need to be reprogrammed

File - Inputs & Outputs Group - Digital Inputs

- 361 (Digital In1 Sel) = N/A
- 362 (Digital In2 Sel) = N/A
- 363 (Digital In3 Sel) = N/A
- 364 (Digital In4 Sel) = 15
- 365 (Digital In5 Sel) = 16
- 366 (Digital In6 Sel) = N/A

Terminal				
6	5	4	Speed Command Source	
0	0	0	Speed Ref A Sel, See Par #090	Default is Analog In 2, 0-10 Volts
0	0	1	Speed Ref B Sel, See Par #093	Default is Preset 1, Par #101
0	1	0	Preset Speed 2, Par #102	
0	1	1	Preset Speed 3, Par #103	
1	0	0	Preset Speed 4, Par #104	
1	0	1	Preset Speed 5, Par #105	
1	1	0	Preset Speed 6, Par #106	
1	1	1	Preset Speed 7, Par #107	

Parameters that need to be reprogrammed

File - Speed Command Group - Speed References

- 90 (Speed Ref A Sel) = 2 (Analog In 2)
- 93 (Speed Ref B Sel) = 11 (Preset Spd 1)

File - Speed Command Group - Discrete Speeds

- 101 (Preset Speed 1) = 10 Hz
- 102 (Preset Speed 2) = 30 Hz