

# 0 to 10 Volts Speed Command

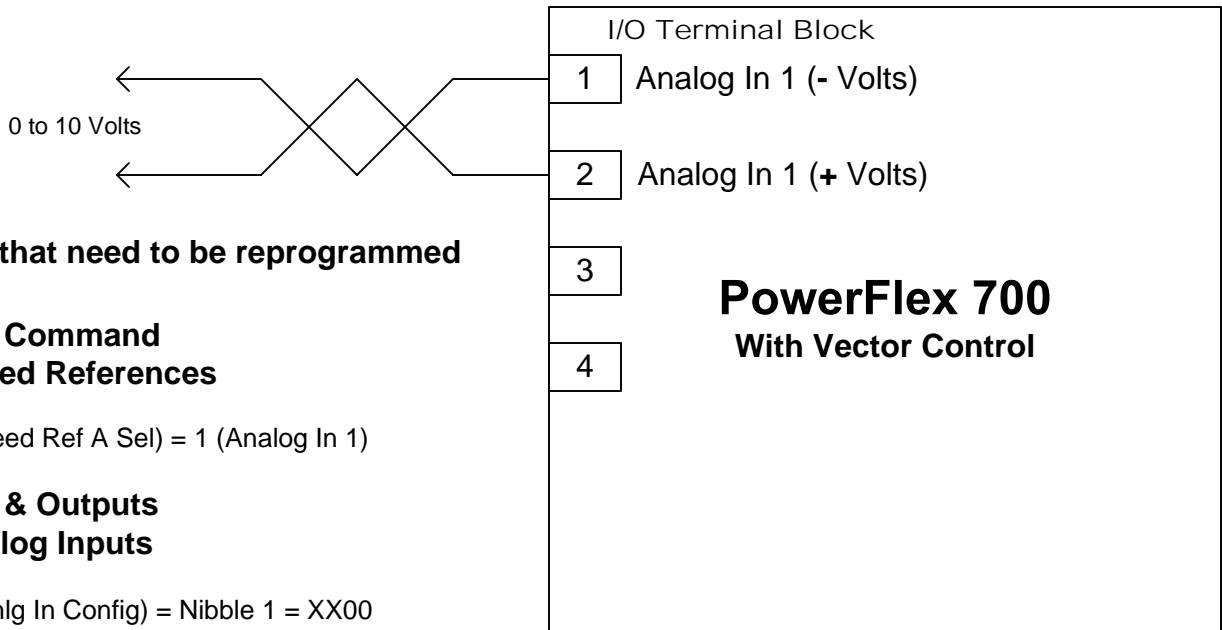

Or

