

2 Wire Run FWD/REV, Enable, AUX Fault, Clear Fault User Supplied 115 AC volt Logic power

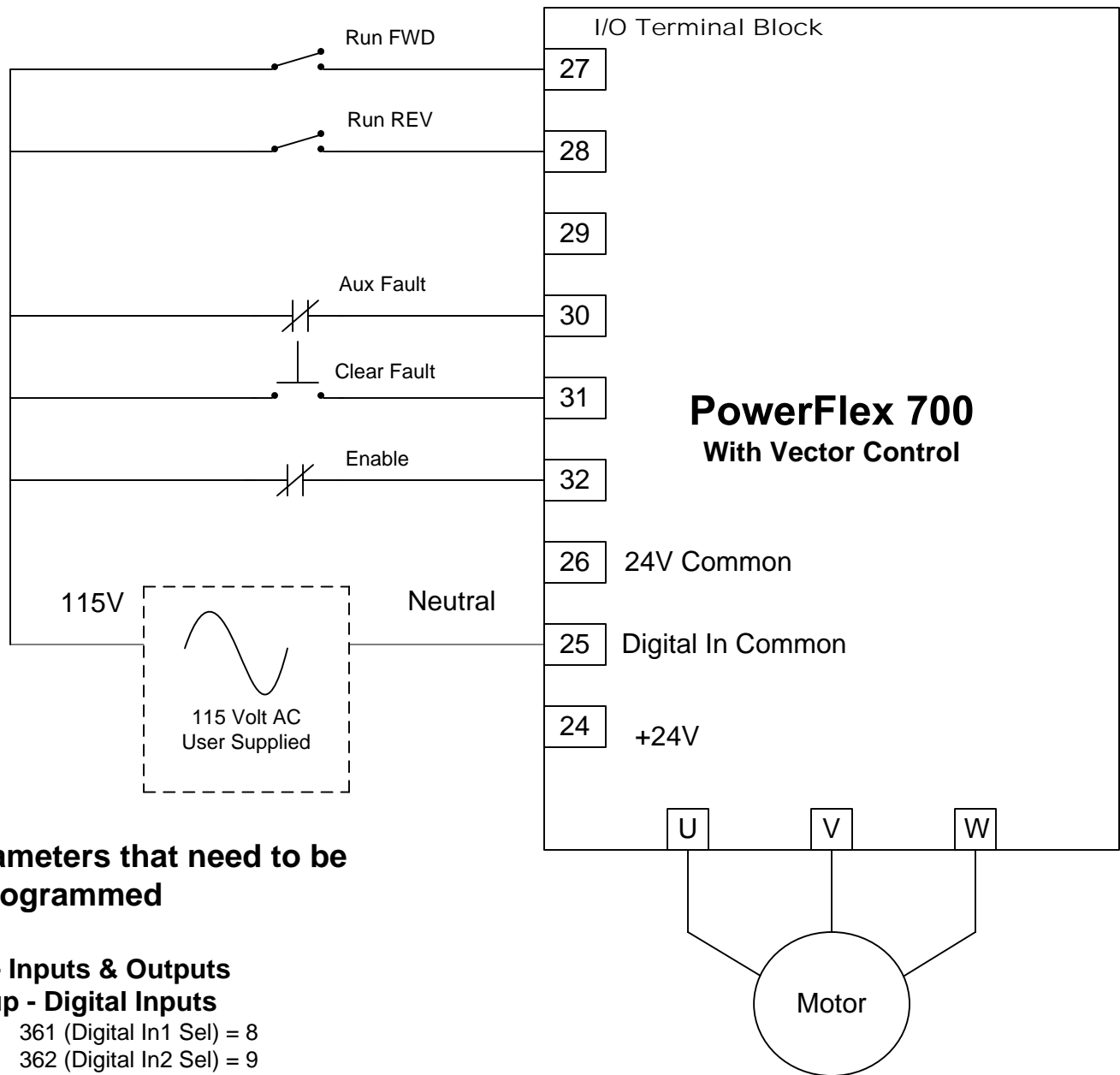

Parameters that need to be reprogrammed

File - Inputs & Outputs Group - Digital Inputs

- 361 (Digital In1 Sel) = 8
- 362 (Digital In2 Sel) = 9
- 363 (Digital In3 Sel) = 0
- 364 (Digital In4 Sel) = 3
- 365 (Digital In5 Sel) = 2
- 366 (Digital In6 Sel) = 1

Hardware Enable Circuitry

By default, the user can program a digital input as an Enable input. The status of this input is *interpreted by drive software*. If the application requires the drive to be disabled *without* software interpretation, a "dedicated" hardware enable configuration can be utilized. This is done by removing a jumper and wiring the enable input to "Digital In 6" (see image of jumper).

1. Remove the I/O Control Cassette & cover.
2. Locate & remove Jumper J10 on the Main Control Board.
3. Re-assemble cassette.
4. Wire Enable to "Digital In 6" (Terminal 32).
5. Verify that [Digital In6 Sel], parameter 366 is set to "1, Enable."

