

4-20mA Speed Command

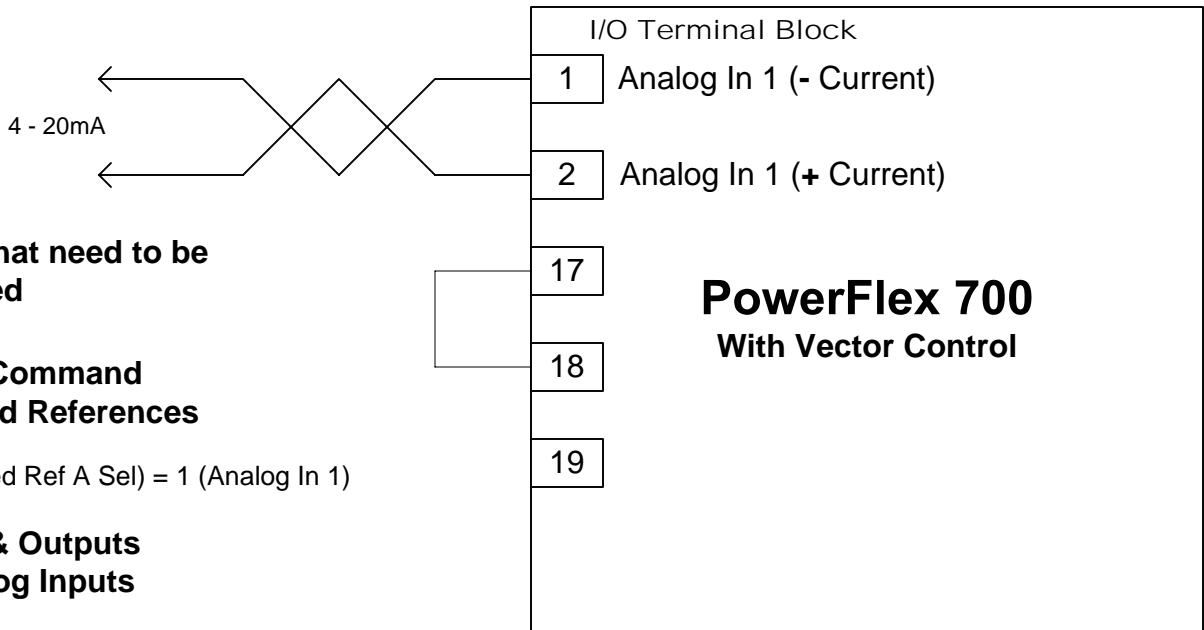

Parameters that need to be reprogrammed

File - Speed Command Group - Speed References

90 (Speed Ref A Sel) = 1 (Analog In 1)

File - Inputs & Outputs Group - Analog Inputs

320 (Anlg In Config) = Nibble 1 = XX01

322 (Analog In 1 Hi) = 20.000mA

323 (Analog In 1 Lo) = 4.000mA

Or

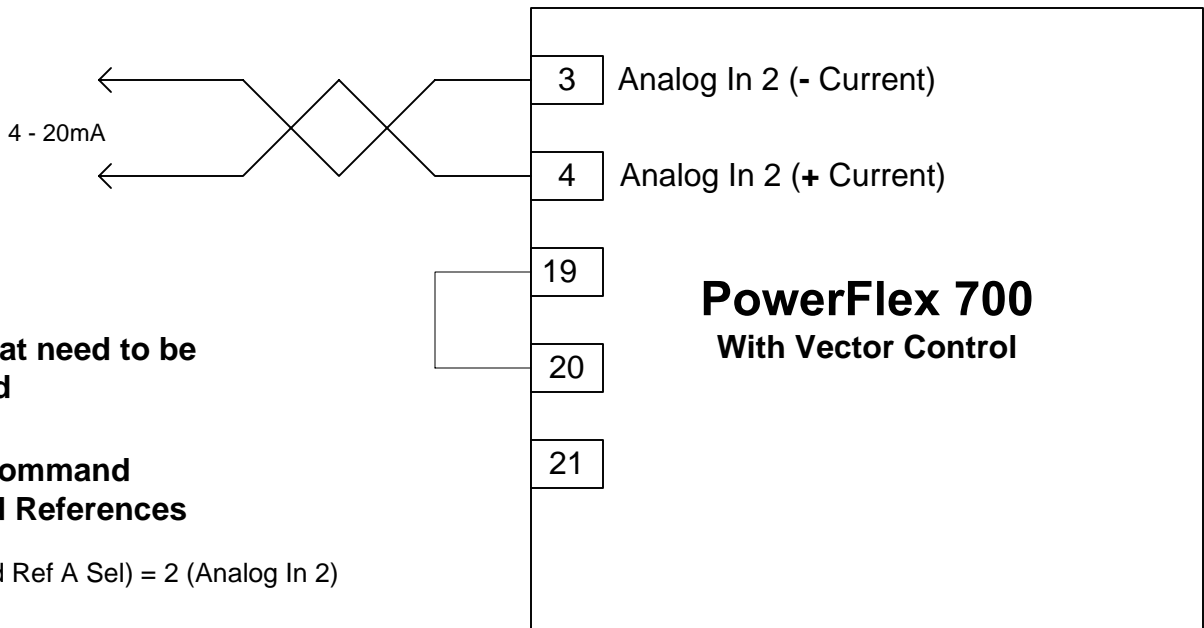

Parameters that need to be reprogrammed

File - Speed Command Group - Speed References

90 (Speed Ref A Sel) = 2 (Analog In 2)

File - Inputs & Outputs Group - Analog Inputs

320 (Anlg In Config) = Nibble 1 = XX10

325 (Analog In 2 Hi) = 20.000mA

326 (Analog In 2 Lo) = 4.000mA