

Auto/Manual Application

User Supplied 115 Volt AC Logic power

Note:

Auto = Speed reference from DPI Port 1 (HIM)

Manual = Speed reference from Speed Pot

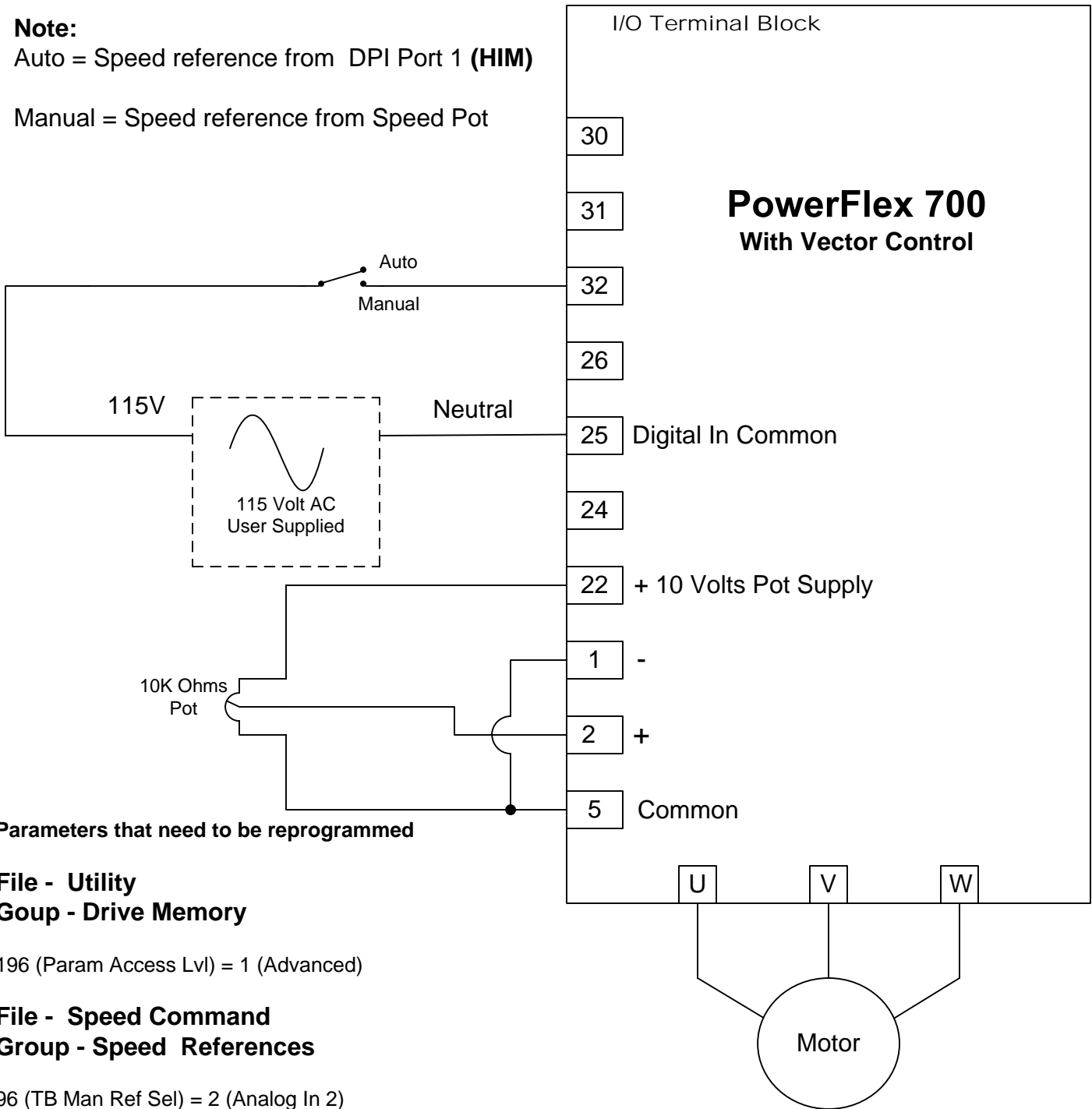

Parameters that need to be reprogrammed

File - Utility
Group - Drive Memory

196 (Param Access Lvl) = 1 (Advanced)

File - Speed Command
Group - Speed References

96 (TB Man Ref Sel) = 2 (Analog In 2)
 90 (Speed Ref A Sel) = 18 (DPI Port 1)

File - Speed Command
Group - Speed Trim

117 (Trim In Select) = 20 (DPI Port 3)

File - Speed Command
Group - Process PI

128 (PI Feedback Sel) = 20 (DPI Port 3)

File - Inputs & Outputs
Group - Digital Inputs

366 (Digital In6 Sel) = 18 (Auto/Manual)