

Speed Pot Connections and Programming

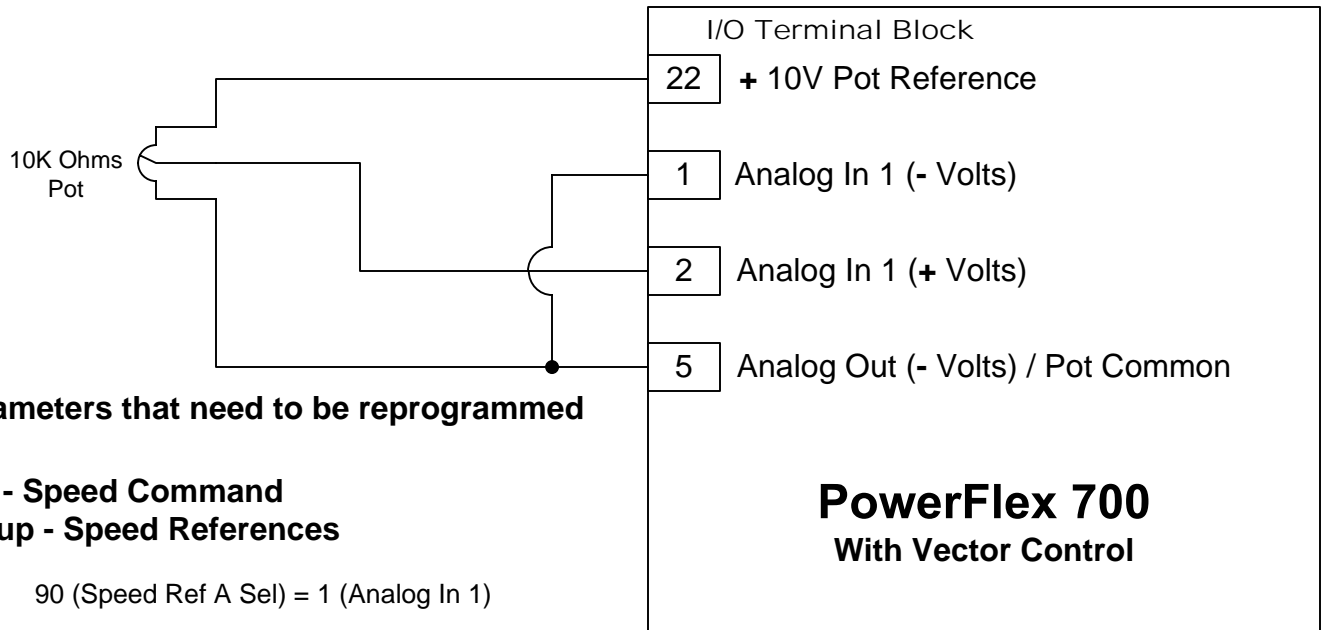

Parameters that need to be reprogrammed

**File - Speed Command
Group - Speed References**

90 (Speed Ref A Sel) = 1 (Analog In 1)

**File - Inputs & Outputs
Group - Analog Inputs**

320 (Anlg In Config) = Nibble 1 = XX00

Or

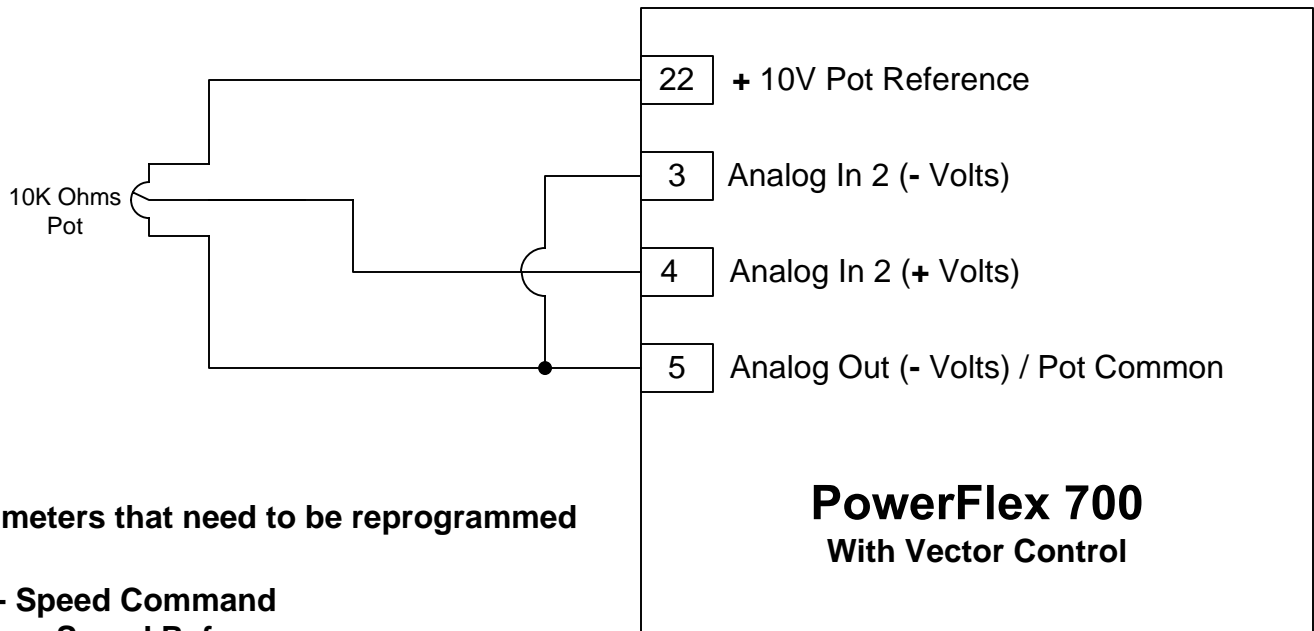

Parameters that need to be reprogrammed

**File - Speed Command
Group - Speed References**

90 (Speed Ref A Sel) = 2 (Analog In 2)

**File - Inputs & Outputs
Group - Analog Inputs**

320 (Anlg In Config) = Nibble 1 = XX00