

Using MOP Speed Control

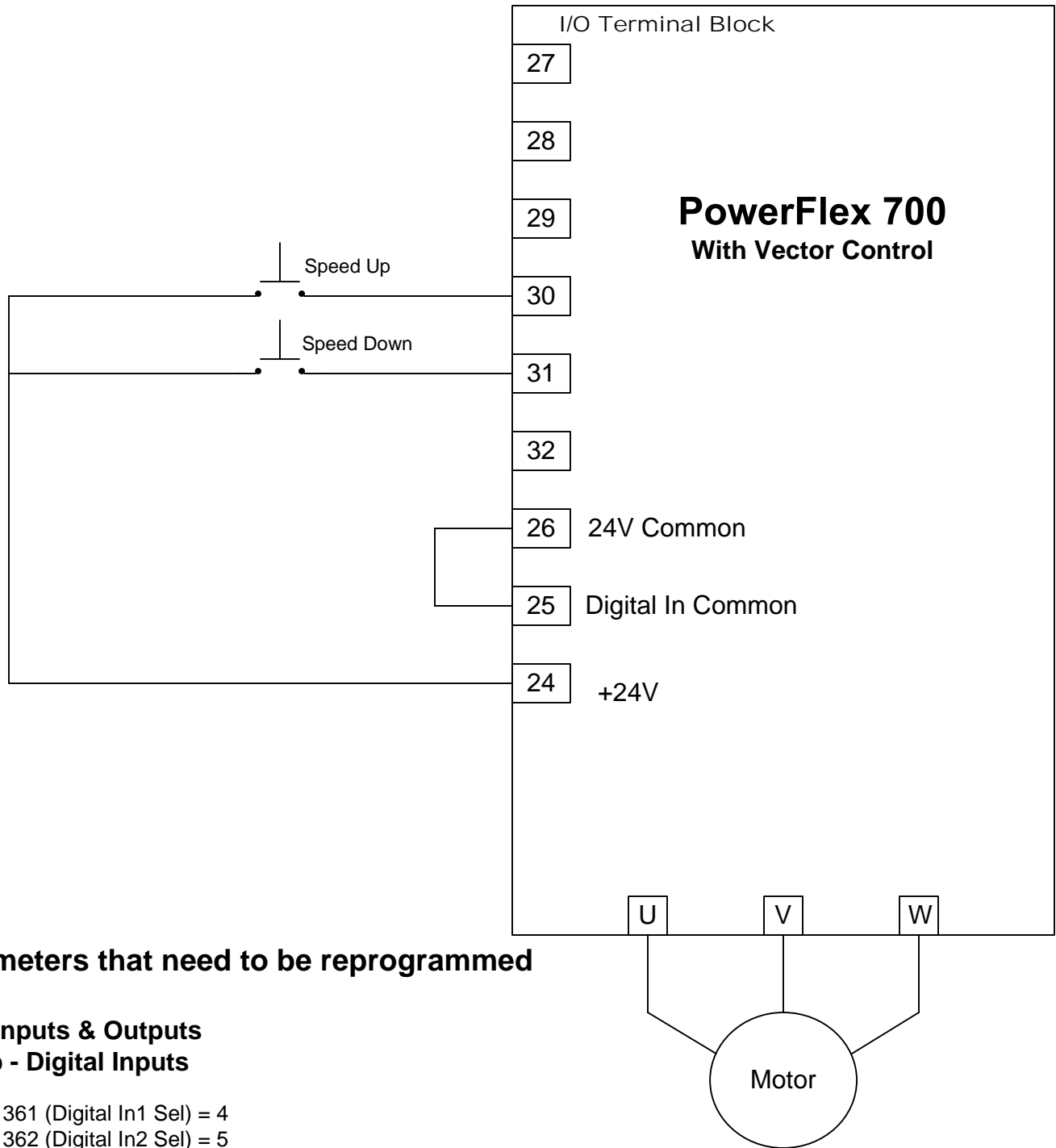

Parameters that need to be reprogrammed

File - Inputs & Outputs

Group - Digital Inputs

- 361 (Digital In1 Sel) = 4
- 362 (Digital In2 Sel) = 5
- 363 (Digital In3 Sel) = 10
- 364 (Digital In4 Sel) = 23
- 365 (Digital In5 Sel) = 24
- 366 (Digital In6 Sel) = 17

File - Speed Command

Group - Speed References

- 90 (Speed Ref A Sel) = 9 (MOP Level)