

# Dynamic Braking Kit

## for FlexPak 3000 and WebPak 3000 Digital DC Drives

### 1.5 HP to 150 HP @ 230 VAC, 3 HP to 600 HP @ 460 VAC

### without NEMA1 Enclosures

Model Numbers 912FKxxxx and 913FKxxxx

Instruction Manual D2-3374-4



**ATTENTION:** Only qualified personnel familiar with the construction and operation of this equipment and the hazards involved should install, operate, and/or service this equipment. Read and understand this instruction manual in its entirety before proceeding. Failure to observe this precaution could result in severe bodily injury or loss of life.

**ATTENTION:** The user is responsible for conforming with all applicable local, national, and international codes. Failure to observe this precaution could result in damage to, or destruction of, the equipment.

## Product Description

This instruction manual describes how to install optional Dynamic Braking (DB) kits that are used with FlexPak™ 3000 (1.5 HP to 150 HP @ 230 VAC, 3 HP to 600 HP @ 460 VAC) and WebPak™ 3000 (1.5 HP to 75 HP @ 230 VAC, 3 HP to 150 HP @ 460 VAC) DC drives. These kits consist of separate parts that must be mounted by the customer. See the following table to verify the kit matches your drive.

| Drive<br>Horsepower | Kit Model Number |           | Drive<br>Horsepower | Kit Model Number |           |
|---------------------|------------------|-----------|---------------------|------------------|-----------|
|                     | 230 VAC          | 460 VAC   |                     | 230 VAC          | 460 VAC   |
| 1.5                 | 912FK0010        | —         | 60                  | 912FK0500        | 913FK0500 |
| 2                   | 912FK0020        | —         | 75                  | 912FK0750        | 913FK0750 |
| 3                   | 912FK0030        | 913FK0030 | 100                 | 912FK1000        | 913FK1000 |
| 5                   | 912FK0050        | 913FK0050 | 125                 | 912FK1250        | 913FK1000 |
| 7.5                 | 912FK0070        | 913FK0070 | 150                 | 912FK1500        | 913FK1500 |
| 10                  | 912FK0100        | 913FK0100 | 200                 | —                | 913FK2000 |
| 15                  | 912FK0150        | 913FK0150 | 250                 | —                | 913FK2500 |
| 20                  | 912FK0200        | 913FK0200 | 300                 | —                | 913FK3000 |
| 25                  | 912FK0250        | 913FK0200 | 400                 | —                | 913FK4000 |
| 30                  | 912FK0300        | 913FK0300 | 500                 | —                | 913FK5000 |
| 40                  | 912FK0400        | 913FK0400 | 600                 | —                | 913FK6000 |
| 50                  | 912FK0500        | 913FK0500 |                     |                  |           |

## 1.5 HP to 150HP @ 230 VAC, 3 HP to 300 HP @ 460 VAC Drives

When the motor is running normally, the drive's normally-closed DB contactor is open and the dynamic braking resistor (dynamic braking grid) is disconnected. See figure 3.

Dynamic braking slows down a rotating DC motor and its load if the motor is disconnected from the drive. It is typically initiated with a coast/DB stop command or a drive fault. When dynamic braking is initiated, the normally-closed DB contactor, shown in figure 3, closes. The DB resistor is then connected across the motor armature; A1 and A2. The motor's rotating armature now acts as a generator. The resulting current causes braking torque in the motor. While the motor is decelerating, its energy is absorbed by the DB resistor. This causes this resistor's temperature to increase. Dynamic braking decelerates the motor even with a drive failure, as long as motor field excitation is maintained. This process is not controlled by software. The following table lists the contents of the 1.5 to 300 HP Dynamic Braking kits.

| Description   | Quantity | Reliance Part Number     |
|---|----------|--------------------------|
| Contactors  | 1        | 705310-1xxA <sup>1</sup> |
| Suppressor  | 1        | 600686-33A               |
| Resistor Assembly:<br>1.5 HP to 150 HP @ 230 VAC and 3 HP to 200 HP @ 460 VAC<br>or<br>250 HP to 300 HP @ 460 VAC | 1        | 800160-20xx <sup>1</sup> |
|   | 1        | 802272-53x <sup>1</sup>  |
| Enclosure:<br>1.5 HP to 150 HP @ 230 VAC and 3 HP to 200 HP @ 460 VAC<br>or<br>250 HP to 300 HP @ 460 VAC         | 1        | 800798-54R               |
|   | 1        | 802272-52S               |

<sup>1</sup>. See table 4 for the specific part number for your kit model number.

## 400 HP to 600 HP @ 460 VAC Drives

The 400 HP to 600 HP @ 460 VAC drives include a DC contactor and therefore only require the resistor assembly (DB resistor). The wiring requirements are also different for these drives.

When the motor is running normally, the drive's normally-open M contacts are closed and the normally-closed M contact is open. See figure 5. Note that when the drive is connected to the motor, the dynamic braking resistor (dynamic braking grid) is disconnected.

Dynamic braking slows down a rotating DC motor and its load if the motor is disconnected from the drive. It is typically initiated with a coast/DB stop command or a drive fault. When dynamic braking is initiated, the normally-open M contacts open, the normally-closed M contact closes. The drive is then disconnected from the motor and the dynamic braking resistor is connected across the armature; A1 and A2. The motor's rotating armature now acts as a generator. The resulting current causes braking torque in the motor. While the motor is decelerating, its energy is absorbed by the DB resistor. This causes this resistor's temperature to increase. Dynamic braking decelerates the motor even with a drive failure, as long as motor field excitation is maintained. This process is not controlled by software. The following table lists the contents of the 400 HP to 600 HP Dynamic Braking kits.

| Description  | Quantity | Reliance Part Number    |
|--|----------|-------------------------|
| Resistor Assembly:<br>400 HP to 600 HP @ 460 VAC     | 1        | 802272-53x <sup>1</sup> |
| Enclosure:<br>400 HP to 600 HP @ 460 VAC             | 1        | 802272-52S              |
| Hardware for Mounting:<br>5/16 -18x3/4 Carriage Bolt | 4        | 601745-2A               |
| 5/16 -18 KEP Nut                                     | 4        | 401599-11F              |
| Grommet  | 1        | 603100-A                |
| #10-32 T T Screw                                     | 4        | 601741-63C              |
| #10 Flat Washer                                      | 4        | 601748-1C               |
| Screw, Hex HD. M10x25mm                              | 2        | 419062-5HLM             |
| Flat Washer, M10                                     | 2        | 419064-1SL              |
| KEP Nut, M10   | 2        | 419063-201SL            |

<sup>1</sup>. See table 4 for the specific part number for your kit model number.

| DB Kit Model Number | Contactors Part Number | Resistor Assembly Part Number | Replacement Resistor Part Number | Number of Resistors in Assembly | Total Ohms |
|---------------------|------------------------|-------------------------------|----------------------------------|---------------------------------|------------|
| 912FK0010           | 705310-141A            | 800160-20P                    | 48267-P                          | 1                               | 20.87      |
| 912FK0020           | 705310-141A            | 800160-20R                    | 48267-J <sup>1</sup>             | 2                               | 11.86      |
| 912FK0030           | 705310-141A            | 800160-20S                    | 48267-H <sup>1</sup>             | 2                               | 9.39       |
| 912FK0050           | 705310-141A            | 800160-20T                    | 48267-F <sup>1</sup>             | 2                               | 6.088      |
| 912FK0070           | 705310-141A            | 800160-20V                    | 48267-D <sup>1</sup>             | 2                               | 3.824      |
| 912FK0100           | 705310-141A            | 800160-20W                    | 48267-C <sup>1</sup>             | 2                               | 3.046      |
| 912FK0150           | 705310-141A            | 800160-20X                    | 48267-A <sup>1</sup>             | 2                               | 1.932      |
| 912FK0200           | 705310-141A            | 800160-20Y                    | 48267-C <sup>2</sup>             | 4                               | 1.523      |
| 912FK0250           | 705310-141A            | 800160-20RB                   | 48267-B <sup>2</sup>             | 4                               | 1.212      |
| 912FK0300           | 705310-141A            | 800160-20RC                   | 48267-A <sup>2</sup>             | 4                               | 0.966      |
| 912FK0400           | 705310-150A            | 800160-20RD                   | 402422-3F <sup>1</sup>           | 2                               | 0.998      |
| 912FK0500           | 705310-150A            | 800160-20RE                   | 402422-3G <sup>1</sup>           | 2                               | 0.780      |
| 912FK0750           | 705310-160A            | 800160-20RF                   | 402422-3K <sup>1</sup>           | 2                               | 0.498      |
| 912FK1000           | 705310-170A            | 800160-20RG                   | 402422-3L <sup>1</sup>           | 2                               | 0.382      |
| 912FK1250           | 705310-180A            | 800160-20RH                   | 402422-3P <sup>1</sup>           | 3                               | 0.372      |
| 912FK1500           | 705310-180A            | 800160-20RJ                   | 402422-3Q <sup>1</sup>           | 3                               | 0.315      |
| 913FK0030           | 705310-141A            | 800160-20SP                   | 48267-N <sup>1</sup>             | 3                               | 49.35      |
| 913FK0050           | 705310-141A            | 800160-20SR                   | 48267-K <sup>1</sup>             | 3                               | 22.34      |
| 913FK0070           | 705310-141A            | 800160-20SS                   | 48267-J <sup>1</sup>             | 3                               | 17.79      |
| 913FK0100           | 705310-141A            | 800160-20ST                   | 48267-H <sup>1</sup>             | 3                               | 14.09      |
| 913FK0150           | 705310-141A            | 800160-20SV                   | 48267-F <sup>1</sup>             | 3                               | 9.132      |
| 913FK0200           | 705310-141A            | 800160-20SW                   | 48267-C <sup>1</sup>             | 4                               | 6.09       |
| 913FK0300           | 705310-141A            | 800160-20SX                   | 48267-B <sup>1</sup>             | 4                               | 4.85       |
| 913FK0400           | 705310-141A            | 800160-20SY                   | 48267-A <sup>1</sup>             | 4                               | 3.864      |
| 913FK0500           | 705310-141A            | 800160-20SB                   | 402422-3D <sup>1</sup>           | 3                               | 3.00       |
| 913FK0750           | 705310-150A            | 800160-20SC                   | 402422-3E <sup>1</sup>           | 3                               | 2.25       |
| 913FK1000           | 705310-150A            | 800160-20SD                   | 402422-3F <sup>1</sup>           | 3                               | 1.497      |
| 913FK1500           | 705310-160A            | 800160-20SE                   | 402422-3J <sup>1</sup>           | 4                               | 1.24       |
| 913FK2000           | 705310-170A            | 800160-20SF                   | 402422-3K <sup>1</sup>           | 4                               | 0.996      |
| 913FK2500           | 705310-180A            | 802272-53R                    | 402422-7Z <sup>1</sup>           | 2                               | 0.714      |
| 913FK3000           | 705310-180A            | 802272-53S                    | 402422-7AD <sup>1</sup>          | 2                               | 0.644      |
| 913FK4000           | —                      | 802272-53T                    | 402422-7AH <sup>1</sup>          | 2                               | 0.470      |
| 913FK5000           | —                      | 802272-53V                    | 402422-7AL <sup>1</sup>          | 2                               | 0.412      |
| 913FK6000           | —                      | 802272-53W                    | 402422-7AN <sup>1</sup>          | 2                               | 0.324      |

1. Series connection

2. Series/parallel connection consisting of two pairs of two resistors connected in series. The pairs of resistors are then connected in parallel.

## Installing the Dynamic Braking Kit for 1.5 HP to 150 HP @ 230 VAC and 3 HP to 300 HP @ 460 VAC Drives



**ATTENTION:** Only qualified personnel familiar with the construction and operation of this equipment and the hazards involved should install, operate, and/or service this equipment. Read and understand this instruction manual in its entirety before proceeding. Failure to observe this precaution could result in severe bodily injury or loss of life.

**ATTENTION:** The drive is at line voltage when connected to incoming AC power. Disconnect, tag and lockout all incoming power to the drive before performing the following procedure. Failure to observe this precaution could result in severe bodily injury or loss of life.

**ATTENTION:** The user is responsible for conforming with all applicable local, national, and international codes. Failure to observe this precaution could result in damage to, or destruction of, the equipment.

- Step 1. Turn off, lock out, and tag power to the drive.
- Step 2. Determine where you will mount the Dynamic Braking kit. Typically, the Dynamic Braking kit mounts on the roof of the drive cabinet or within the drive enclosure. Mount the kit components as required. The supplied enclosure may be mounted over the resistor assembly, if desired. See figures 1 and 2 for contactor and dynamic braking resistor assembly mounting dimensions.



**ATTENTION:** DB resistors may be extremely hot. Install in an enclosure or provide adequate clearance to ensure that nothing can come in direct contact with, or in proximity to, the DB resistors. Failure to observe this precaution can result in severe burns and damage to, or destruction of, the equipment.

- Step 3. Follow the wiring diagram in figure 3 to connect the motor armature, the DB contactor, and the DB resistor assembly to the drive.
- Step 4. Install the supplied suppressor (P/N 600686-33A) across the contactor coil. This suppressor is resistor 2SSR shown across the DB coil in figure 3.
- Step 5. Remove the jumper from the Field/DB terminal block on the drive (terminals 3 to 4). See figure 3. Connect the auxiliary contactor (DB AUX), terminals 13 and 14, to terminals 3 and 4, respectively, on the Field/DB terminal block.
- Step 6. Connect the user-supplied 115 VAC control power to the Dynamic Braking contactor (DBCR) and control circuit (Field/DB terminal block, terminals 1 and 2) as shown in figure 3. The control power continuous and inrush VA requirements are listed at the end of this manual in table 5.
- Step 7. Remove the lockout and tag from the power to the drive.
- Step 8. Turn on power to the drive.

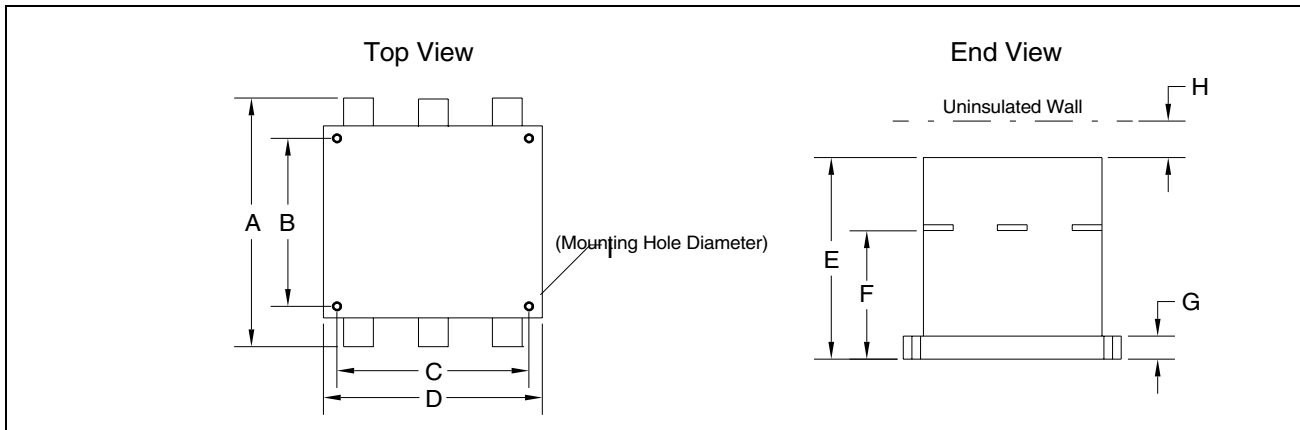

| Contactor Part No.<br>Drive HP Range                                   | Dimension          |                   |                   |                   |                   |                   |                    |                  |                   |
|--|--------------------|-------------------|-------------------|-------------------|-------------------|-------------------|--------------------|------------------|-------------------|
|  | A                  | B                 | C                 | D                 | E                 | F                 | G                  | H                | I                 |
| <b>705310-141A</b><br>1.5 - 30 HP @ 240 VDC<br>3 - 60 HP @ 500 VDC     | 171 mm<br>6.73 in  | 120 mm<br>4.72 in | 110 mm<br>4.33 in | 124 mm<br>4.88 in | 143 mm<br>5.63 in | 91 mm<br>3.74 in  | 19 mm<br>0.75 in   | 40 mm<br>1.57 in | 5.7 mm<br>0.23 in |
| <b>705310-150A</b><br>40 - 60 HP @ 240 VDC<br>75 - 125 HP @ 500 VDC    | 198 mm<br>7.8 in   | 140 mm<br>5.52 in | 120 mm<br>4.73 in | 136 mm<br>5.36 in | 168 mm<br>6.62 in | 103 mm<br>4.1 in  | 10.5 mm<br>0.42 in | 15 mm<br>0.6 in  | 6.8 mm<br>0.27 in |
| <b>705310-160A</b><br>75 HP @ 240 VDC<br>150 HP @ 500 VDC              | 198 mm<br>7.8 in   | 140 mm<br>5.52 in | 120 mm<br>4.73 in | 136 mm<br>5.36 in | 168 mm<br>6.62 in | 103 mm<br>4.1 in  | 10.5 mm<br>0.42 in | 15 mm<br>0.6 in  | 6.8 mm<br>0.27 in |
| <b>705310-170A</b><br>100 HP @ 240 VDC<br>200 HP @ 500 VDC             | 207 mm<br>8.2 in   | 140 mm<br>5.52 in | 160 mm<br>6.3 in  | 182 mm<br>7.17 in | 178 mm<br>7.01 in | 107 mm<br>4.22 in | 19 mm<br>0.75 in   | 30 mm<br>1.2 in  | 6.8 mm<br>0.27 in |
| <b>705310-180A</b><br>125 - 150 HP @ 240 VDC<br>250 - 300 HP @ 500 VDC | 272 mm<br>10.71 in | 200 mm<br>7.88 in | 170 mm<br>6.7 in  | 198 mm<br>7.8 in  | 226 mm<br>8.9 in  | 140 mm<br>5.52 in | 23 mm<br>0.91 in   | 45 mm<br>1.78 in | 6.8 mm<br>0.27 in |

Figure 1 – DC Contactor Dimensions

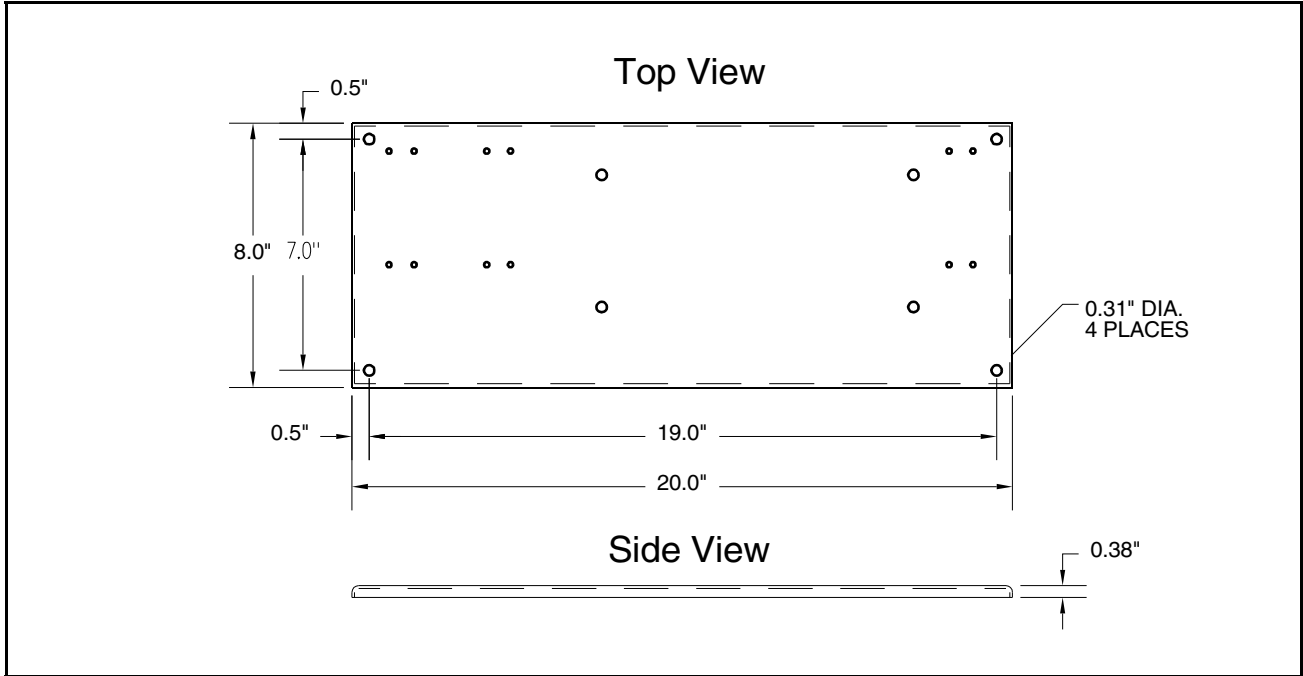

Figure 2 – Resistor Assembly Mounting Dimensions for 1.5 HP to 150 HP @ 230 VAC and 3 HP to 200 HP @ 460 VAC Drives

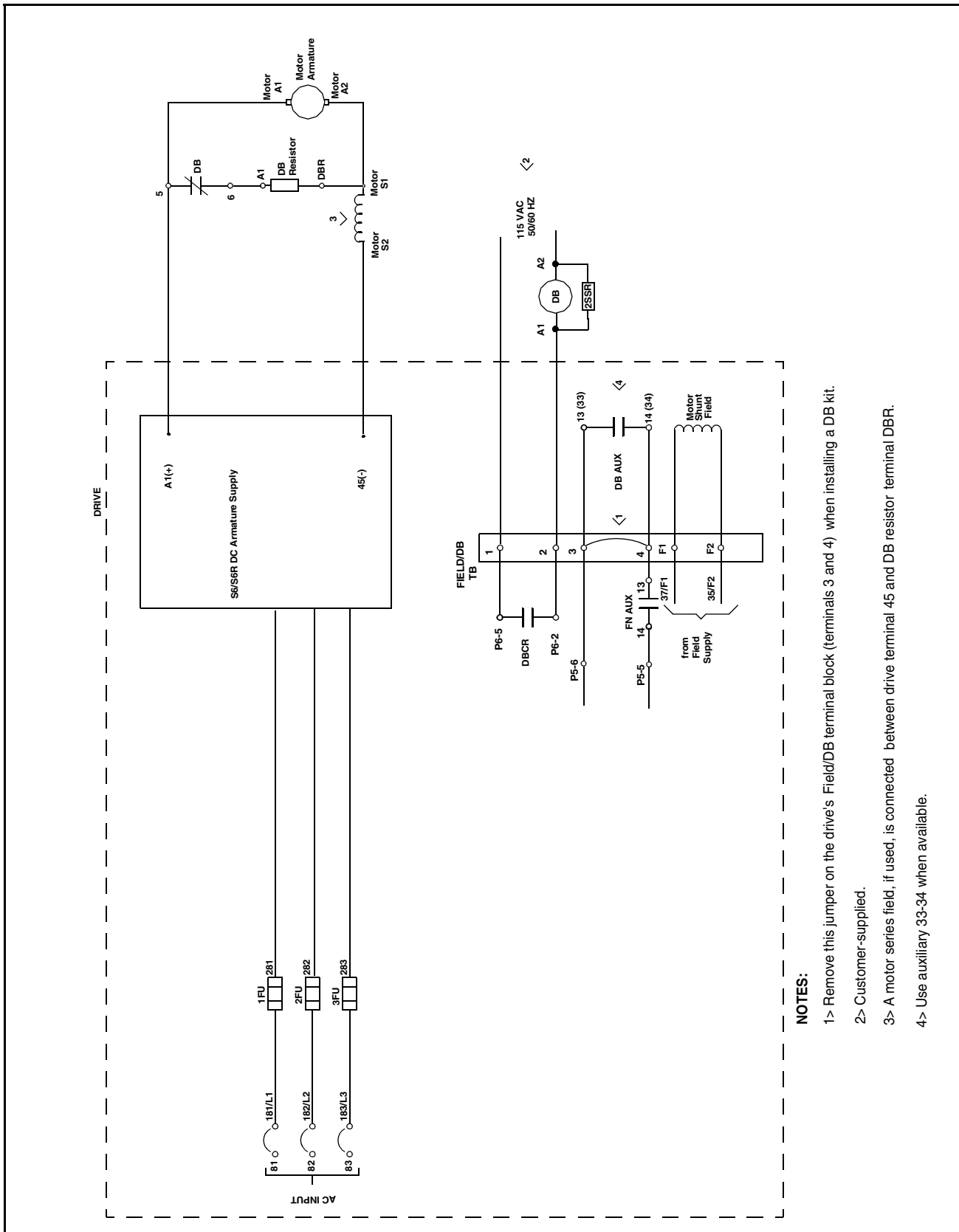

Figure 3 – DB Kit Wiring Diagram for 1.5 HP to 150 HP @ 230 VAC and 3 HP to 300 HP @ 460 VAC Drives

**NOTES:**

- 1> Remove this jumper on the drive's Field/DB terminal block (terminals 3 and 4) when installing a DB kit.
- 2> Customer-supplied.
- 3> A motor series field, if used, is connected between drive terminal 45 and DB resistor terminal DBR.
- 4> Use auxiliary 33-34 when available.

## Installing the DB Kit in 400 HP to 600 HP @ 460 VAC Drives



**ATTENTION:** Only qualified personnel familiar with the construction and operation of this equipment and the hazards involved should install, operate, and/or service this equipment. Read and understand this instruction manual in its entirety before proceeding. Failure to observe this precaution could result in severe bodily injury or loss of life.

**ATTENTION:** The drive is at line voltage when connected to incoming AC power. Disconnect, tag and lockout all incoming power to the drive before performing the following procedure. Failure to observe this precaution could result in severe bodily injury or loss of life.

**ATTENTION:** The user is responsible for conforming with all applicable local, national, and international codes. Failure to observe this precaution could result in damage to, or destruction of, the equipment.

### Mounting the Resistor Assembly

Step 1. Turn off, lock out, and tag power to the drive.

Step 2. Refer to the parts listed in table 3. Determine where you will mount the Dynamic Braking kit. For typical applications, hardware is included for mounting on the roof of the drive cabinet enclosure.



**ATTENTION:** Dynamic braking resistors may be extremely hot. Install in an enclosure or provide adequate clearance to ensure that nothing can come in direct contact with, or in proximity to, the DB resistors. Failure to observe this precaution can result in severe burns and damage to, or destruction of, the equipment.

#### For Cabinet Roof Mounting:

- a. Drill 4 mounting holes and one wire access hole in the cabinet using the dimensions in figure 4.
- b. Install a grommet in the cabinet wire access hole.
- c. Mount the resistor assembly to the roof using 5/16" x 3/4" carriage bolts and nuts.
- d. Route the resistor assembly harness through the holes in the resistor assembly base and cabinet roof.
- e. Remove the top panel from the enclosure and set the screws aside.
- f. Mount the enclosure to the resistor assembly base using 10-32 screws and washers supplied.
- g. Replace the enclosure top panel and reattach screws.

#### Other:

For non-typical applications, mount the kit as required. The kit may be mounted in the bay adjacent to the drive bay. It may be mounted upside down, hanging from the underside of the hood or the enclosure back panel. It may be used with or without the supplied enclosure.

### Wiring the DB Kit

This DB kit can be used with the following drive configurations:

- DB Basic Configuration (shown in figure 5)
- DB with an Inverting Fault Circuit Breaker (shown in figure 7)
- DB with a Motor Series Field, S1 connected to A2 *with* an Inverting Fault Circuit Breaker (figure 8)

- DB with a Motor Series Field, S1 connected to A2 *without* an Inverting Fault Circuit Breaker (figure 8)
- DB with a Motor Series Field, S1 connected to A2/S1 *with* an Inverting Fault Circuit Breaker (figure 9)
- DB with a Motor Series Field, S1 connected to A2/S1 *without* an Inverting Fault Circuit Breaker (figure 9)

Locate and follow the steps for your drive configuration.

**If you are using the Basic Configuration:**

- Step 1. Follow the wiring diagram in figure 5 to connect the motor armature and the Dynamic Braking Resistor assembly to the FlexPak 3000 drive.
- Step 2. Route the resistor assembly harness as required. Use M10 x 25 mm screws, nuts and washers to attach resistor assembly harness to DBR and A2/S1 connections on the drive.
- Step 3. Follow the wiring diagram in figure 5 to verify that the jumper across terminals 3 and 4 on the FIELD/DB terminal block is installed.
- Step 4. Remove the lockout and tag from the power to the drive.
- Step 5. Turn on power to the drive.

**If you are using DB with an Inverting Fault Circuit Breaker:**

- Step 1. Follow the wiring diagram in figure 7 to connect the motor armature and the Dynamic Braking Resistor assembly to the FlexPak 3000 drive.
- Step 2. Remove the Removable Link (see figure 6). It is a bus section below the A2/S1 terminal and is accessed through the top of the drive as shown. At the top, the A2/S1 terminal and Removable Link are fastened with two nuts and bolts, spaced horizontally. Remove them and set them aside along with the A2/S1 terminal for subsequent re-installation. At the bottom, remove the two bolts spaced vertically and set them aside. Take the Removable Link (bus section) out of the drive.
- Step 3. Replace the lower two vertically-spaced bolts and tighten to 23 Nm (200 in-lb).
- Step 4. Replace the A2/S1 terminal fastening it with the upper two horizontally-spaced nuts and bolts previously removed. Tighten to 23 Nm (200 in-lb).
- Step 5. Route the resistor assembly harness as required. Use M10 x 25 mm screws, nuts and washers to attach resistor assembly harness to DBR and A2/S1 connections on the drive. See figure 7.
- Step 6. Connect the Inverting Fault Circuit Breaker kit to the DRV and MOT terminals as shown.
- Step 7. Route the customer-supplied wire (cable) and attach to the connections A2/S1 and MOT (or A2) as shown.
- Step 8. Follow the wiring diagram in figure 5 to verify that the jumper across terminals 3 and 4 on the FIELD/DB terminal block is installed.
- Step 9. Remove the lockout and tag from the power to the drive.
- Step 10. Turn on power to the drive.

**If you are using DB with a Motor Series Field, S1 connected to A2 *with* an Inverting Fault Circuit Breaker:**

- Step 1. Follow the wiring diagram in figure 8 to connect the motor armature and the Dynamic Braking Resistor assembly to the FlexPak 3000 drive.
- Step 2. Remove the Removable Link (see figure 6). It is a bus section below the A2/S1 terminal and is accessed through the top of the drive as shown. At the top, the A2/S1 terminal and Removable Link are fastened with two nuts and bolts, spaced horizontally. Remove them and set them aside along with the A2/S1 terminal for subsequent re-installation. At the bottom, remove the two bolts spaced vertically and set them aside. Take the Removable Link (bus section) out of the drive.
- Step 3. Replace the lower two vertically-spaced bolts and tighten to 23 Nm (200 in-lb).
- Step 4. Replace the A2/S1 terminal fastening it with the upper two horizontally-spaced nuts and bolts previously removed. Tighten to 23 Nm (200 in-lb).
- Step 5. Route the resistor assembly harness as required. Use M10 x 25 mm screws, nuts and washers to attach resistor assembly harness to DBR and A2/S1 connections on the drive. See figure 8.
- Step 6. Connect the Inverting Fault Circuit Breaker kit to the DRV and MOT terminals as shown. Ignore the dashed-line connection.
- Step 7. Route the customer-supplied wire (cable) and attach to the connections A2/S1 and Motor A2 (or Motor S1) as shown.
- Step 8. Connect the Series Field between the terminals Motor S1 and Motor S2.
- Step 9. Follow the wiring diagram in figure 5 to verify that the jumper across terminals 3 and 4 on the FIELD/DB terminal block is installed.
- Step 10. Remove the lockout and tag from the power to the drive.
- Step 11. Turn on power to the drive.

**If you are using DB with a Motor Series Field, S1 connected to A2 *without* an Inverting Fault Circuit Breaker:**

- Step 1. Follow the wiring diagram in figure 8 to connect the motor armature and the Dynamic Braking Resistor assembly to the FlexPak 3000 drive.
- Step 2. Remove the Removable Link (see figure 6). It is a bus section below the A2/S1 terminal and is accessed through the top of the drive as shown. At the top, the A2/S1 terminal and Removable Link are fastened with two nuts and bolts, spaced horizontally. Remove them and set them aside along with the A2/S1 terminal for subsequent re-installation. At the bottom, remove the two bolts spaced vertically and set them aside. Take the Removable Link (bus section) out of the drive.
- Step 3. Replace the lower two vertically-spaced bolts and tighten to 23 Nm (200 in-lb).
- Step 4. Replace the A2/S1 terminal fastening it with the upper two horizontally-spaced nuts and bolts previously removed. Tighten to 23 Nm (200 in-lb).
- Step 5. Route the resistor assembly harness as required. Use M10 x 25 mm screws, nuts and washers to attach resistor assembly harness to DBR and A2/S1 connections on the drive. See figure 8.

- Step 6. Connect the S2 terminal to Motor S1 terminal (see the dashed-line in figure 8). Ignore the Inverting Fault Circuit Breaker illustrated in this figure.
- Step 7. Route the customer-supplied wire (cable) and attach to the connections A2/S1 and Motor A2 (or Motor S1) as shown.
- Step 8. Connect the Series Field between the terminals Motor S1 and Motor S2.
- Step 9. Follow the wiring diagram in figure 5 to verify that the jumper across terminals 3 and 4 on the FIELD/DB terminal block is installed.
- Step 10. Remove the lockout and tag from the power to the drive.
- Step 11. Turn on power to the drive.

**If You are using DB with a Motor Series Field, S1 connected to A2/S1 *with* an Inverting Fault Circuit Breaker:**

- Step 1. Follow the wiring diagram in figure 9 to connect the motor armature and the Dynamic Braking Resistor assembly to the FlexPak 3000 drive.
- Step 2. Remove the Removable Link (see figure 6). It is a bus section below the A2/S1 terminal and is accessed through the top of the drive as shown. At the top, the A2/S1 terminal and Removable Link are fastened with two nuts and bolts, spaced horizontally. Remove them and set them aside along with the A2/S1 terminal for subsequent re-installation. At the bottom, remove the two bolts spaced vertically and likewise set them aside. Take the Removable Link (bus section) out of the drive.
- Step 3. Replace the lower two vertically-spaced bolts and tighten to 23 Nm (200 in-lb).
- Step 4. Replace the A2/S1 terminal fastening it with the upper two horizontally-spaced nuts and bolts previously removed. Tighten to 23 Nm (200 in-lb).
- Step 5. Route the resistor assembly harness as required. Use M10 x 25 mm screws, nuts and washers to attach resistor assembly harness to DBR and A2/S1 connections on the drive. See figure 9.
- Step 6. Connect the Inverting Fault Circuit Breaker kit to the DRV and MOT terminals as shown. Ignore the dashed-line connection.
- Step 7. Route the wire (cable) and attach to the connections A2/S1 and Motor A2 as shown.
- Step 8. Similarly, as shown, route the customer-supplied wire (cable) and attach to the connections A2/S1 and the Motor S1 terminal.
- Step 9. Connect the Series Field between the terminals Motor S1 and Motor S2.
- Step 10. Follow the wiring diagram in figure 5 to verify that the jumper across terminals 3 and 4 on the FIELD/DB terminal block (TB) is installed. Follow the wiring diagram in figure 5 to install the jumper across terminals 3 and 4 on the FIELD/DB terminal block.
- Step 11. Remove the lockout and tag from the power to the drive.
- Step 12. Turn on power to the drive.

**If you are using DB with a Motor Series Field, S1 connected to A2/S1 *without* an Inverting Fault Circuit Breaker:**

- Step 1. Follow the wiring diagram in figure 9 to connect the motor armature and the Dynamic Braking (DB) Resistor assembly to the FlexPak 3000 drive.
- Step 2. Remove the Removable Link (see figure 6). It is a bus section below the A2/S1 terminal and is accessed through the top of the drive as shown. At the top, the A2/S1 terminal and Removable Link are fastened with two nuts and bolts, spaced horizontally. Remove them and set them aside along with the A2/S1 terminal for subsequent re-installation. At the bottom, remove the two bolts spaced vertically and likewise set them aside. Take the Removable Link (bus section) out of the drive.
- Step 3. Replace the lower two vertically-spaced bolts and tighten to 23 Nm (200 in-lb).
- Step 4. Replace the A2/S1 terminal fastening it with the upper two horizontally-spaced nuts and bolts previously removed. Tighten to 23 Nm (200 in-lb).
- Step 5. Route the resistor assembly harness as required. Use M10 x 25 mm screws, nuts and washers to attach resistor assembly harness to DBR and A2/S1 connections on the drive. See figure 9.
- Step 6. Connect the S2 terminal to Motor S1 terminal; see the dashed-line in figure 9. Ignore the Inverting Fault Circuit Breaker illustrated in this figure.
- Step 7. Route the wire (cable) and attach to the connections A2/S1 and Motor A2 as shown.
- Step 8. Similarly, as shown, route the customer-supplied wire (cable) and attach to the connections A2/S1 and the Motor S1 terminal.
- Step 9. Connect the Series Field between the terminals Motor S1 and Motor S2.
- Step 10. Follow the wiring diagram in figure 5 to verify that the jumper across terminals 3 and 4 on the FIELD/DB terminal block is installed. Follow the wiring diagram in figure 5 to install the jumper across terminals 3 and 4 on the FIELD/DB terminal block.
- Step 11. Remove the lockout and tag from the power to the drive.
- Step 12. Turn on power to the drive.

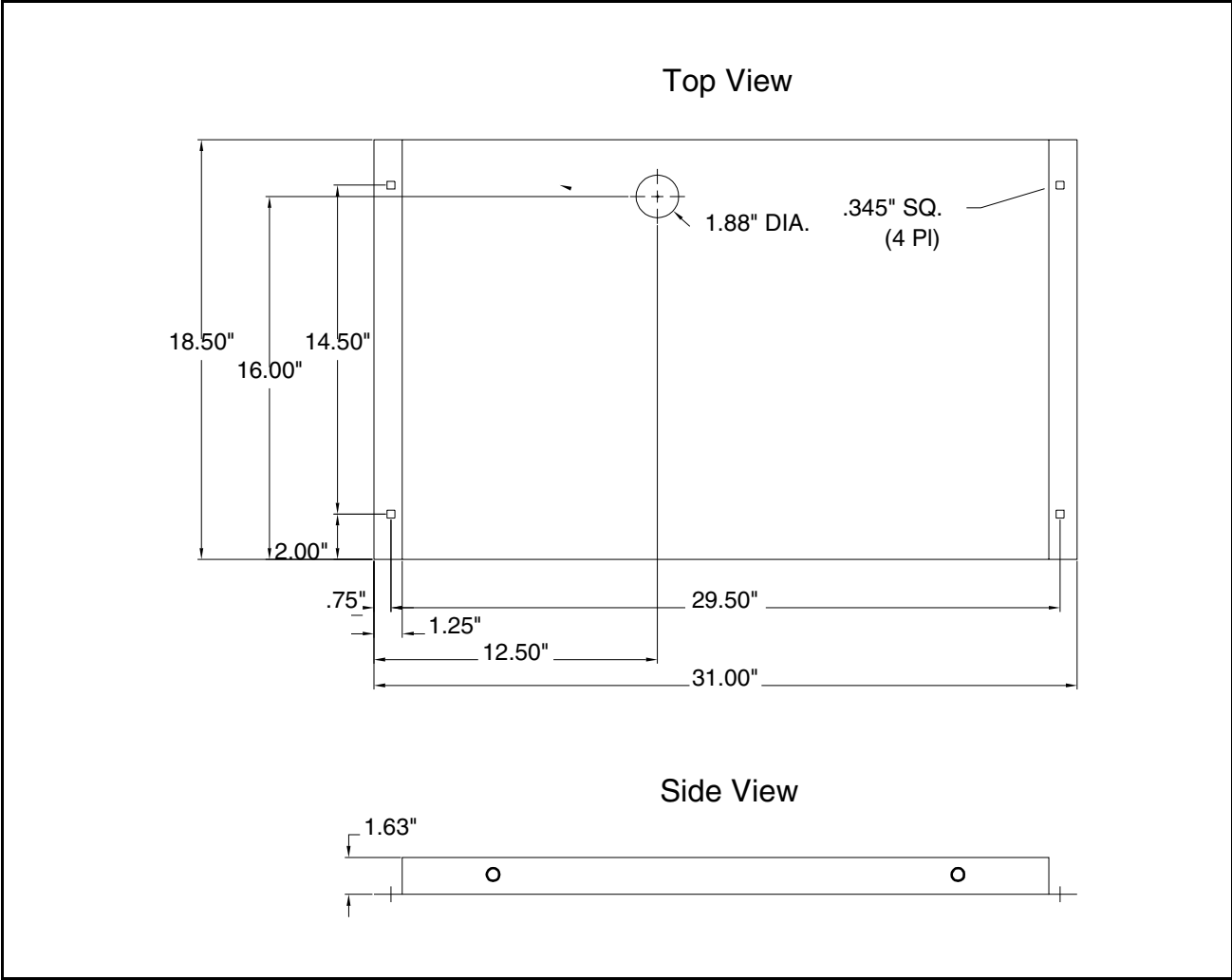
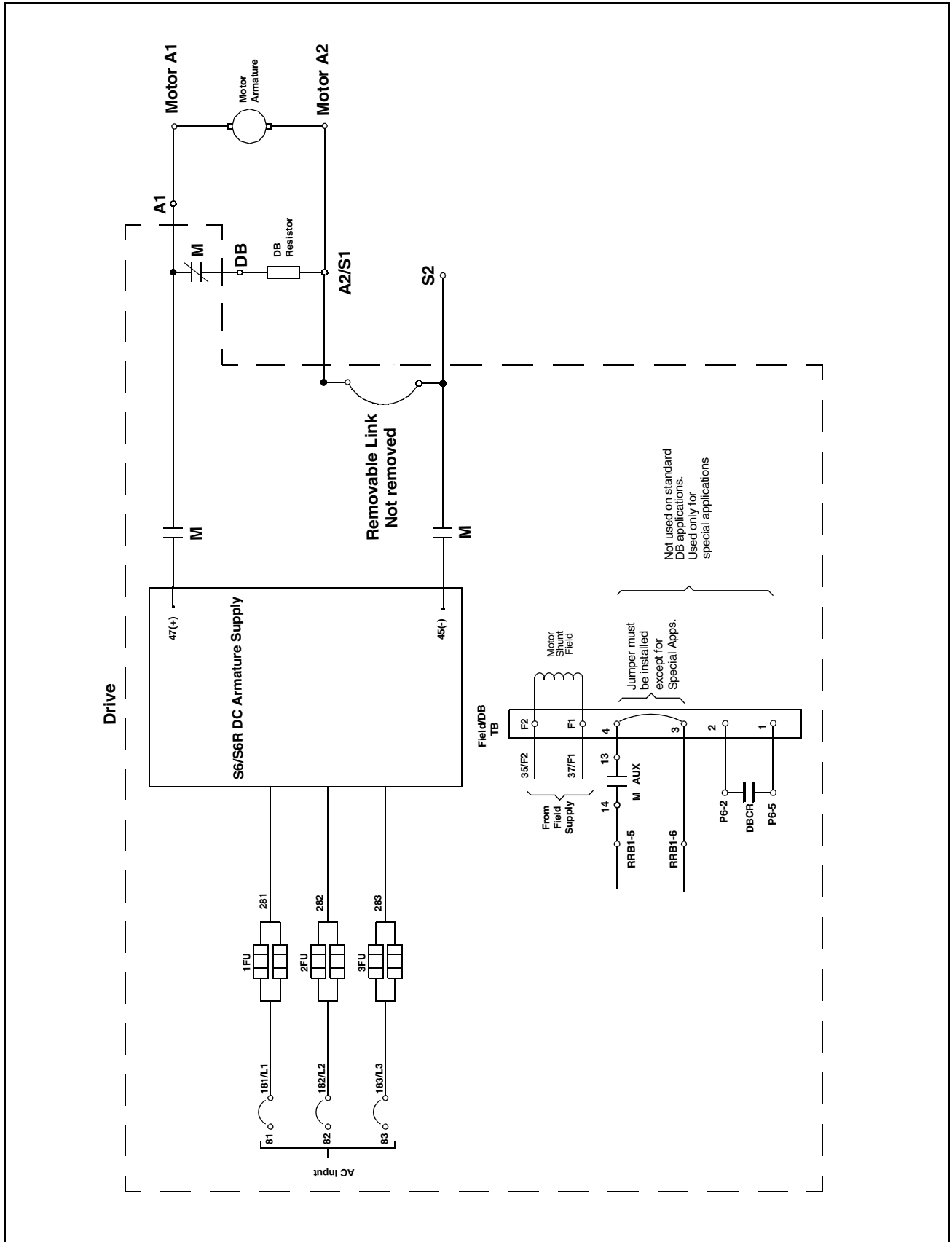

Figure 4 – Resistor Assembly Mounting Dimensions for 250 HP to 600 HP @ 460 VAC Drives



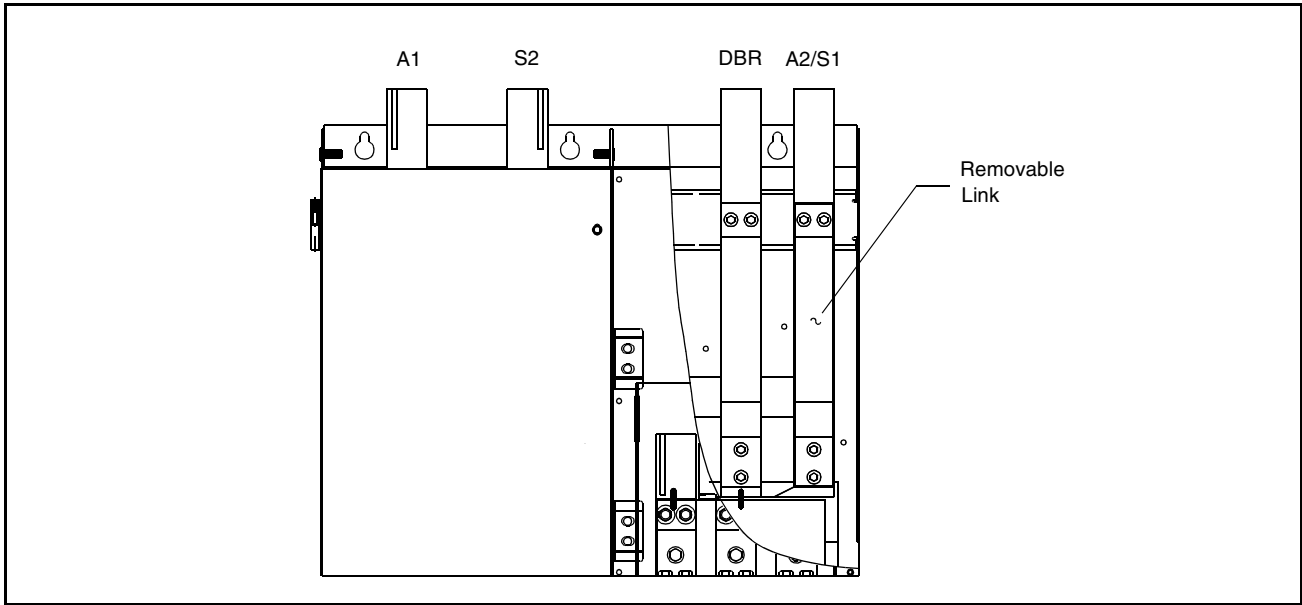

Figure 6 – Removable Link Accessed Through the Top of the Drive

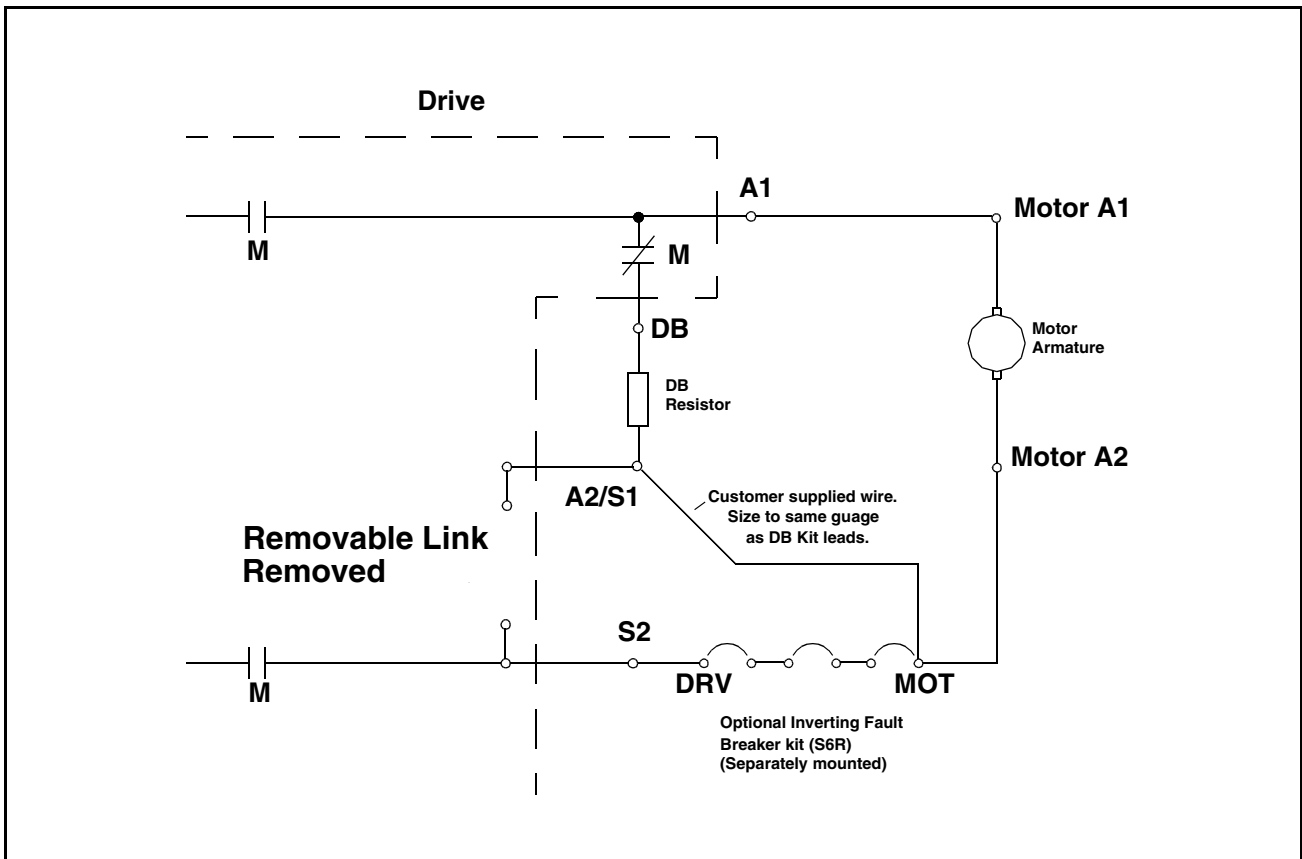

Figure 7 – DB with Inverting Fault Circuit Breaker

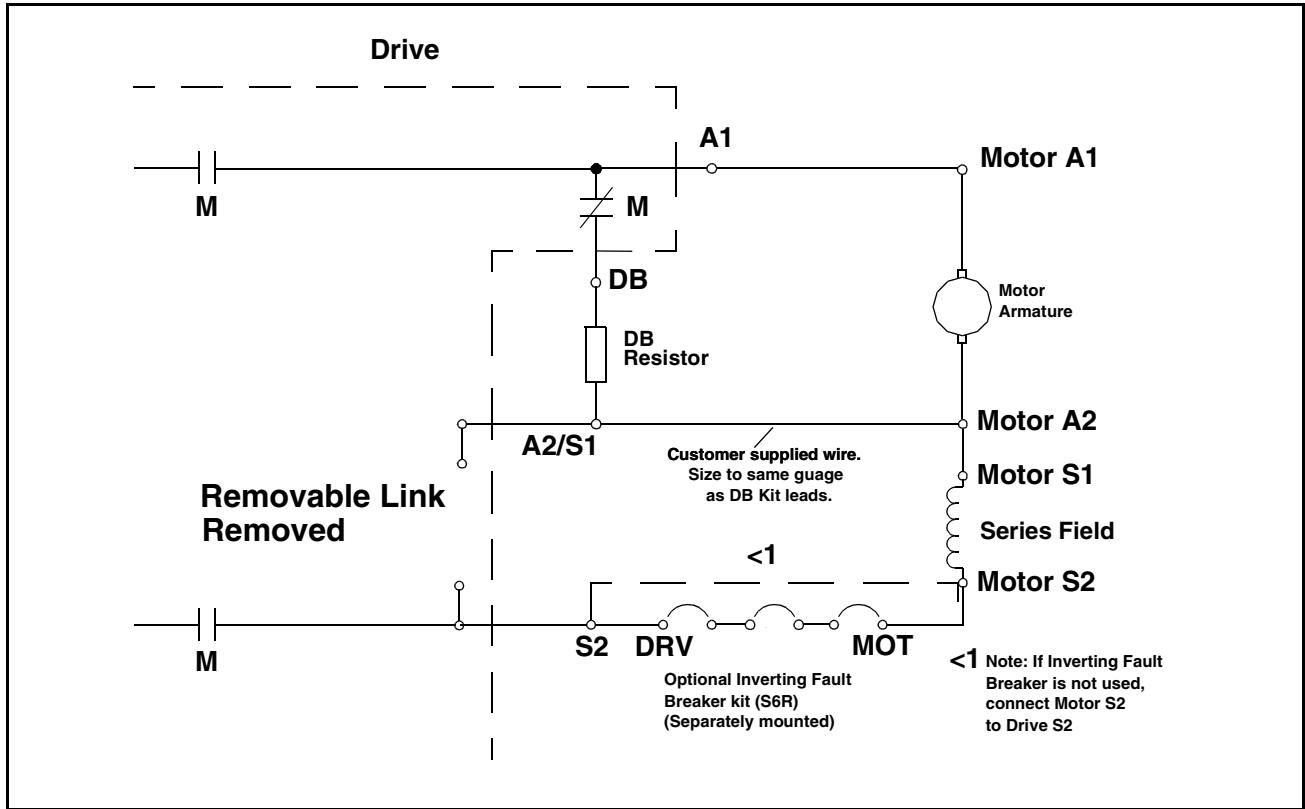

Figure 8 – DB with Series Field and Inverting Fault Circuit Breaker (S1 to A2)

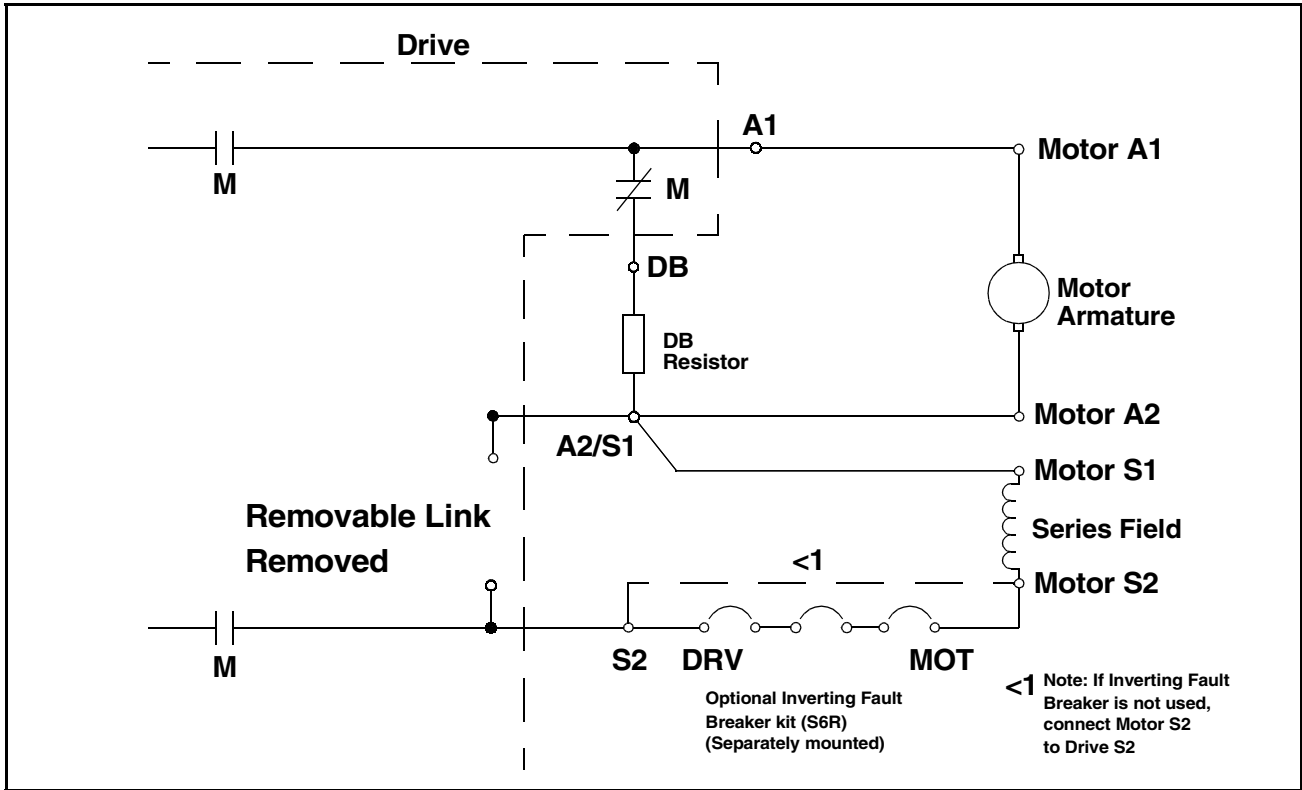

Figure 9 – DB with Series Field and Inverting Fault Circuit Breaker (S1 to A2/S2)

## Technical Specifications

| Contactor       | Drive Horsepower / Voltage Rating | Motor Armature Amps / VDC | VA Inrush | VA Hold  |
|-----------------|-----------------------------------|---------------------------|-----------|----------|
| 705310-141A     | 1.5 HP @ 230 VAC                  | 7 A / 240 VDC             | VA = 490  | VA = 35  |
|                 | 2 HP @ 230 VAC                    | 9 A / 240 VDC             |           |          |
|                 | 3 HP @ 230 VAC                    | 12 A / 240 VDC            |           |          |
|                 | 3 HP @ 460 VAC                    | 6 A / 500 VDC             |           |          |
|                 | 5 HP @ 460 VAC                    | 10 A / 500 VDC            |           |          |
|                 | 7.5 HP @ 460 VAC                  | 14 A / 500 VDC            |           |          |
|                 | 5 HP @ 230 VAC                    | 20 A / 240 VDC            |           |          |
|                 | 7.5 HP @ 230 VAC                  | 29 A / 240 VDC            |           |          |
|                 | 10 HP @ 460 VAC                   | 19 A / 240 VDC            |           |          |
|                 | 15 HP @ 460 VAC                   | 27 A / 240 VDC            |           |          |
|                 | 10 HP @ 230 VAC                   | 38 A / 240 VDC            |           |          |
|                 | 15 HP @ 230 VAC                   | 55 A / 240 VDC            |           |          |
|                 | 20 HP @ 230 VAC                   | 73 A / 240 VDC            |           |          |
|                 | 25 HP @ 230 VAC                   | 93 A / 240 VDC            |           |          |
|                 | 30 HP @ 230 VAC                   | 110 A / 240 VDC           |           |          |
|                 | 20 HP @ 460 VAC                   | 35 A / 500 VDC            |           |          |
|                 | 25 HP @ 460 VAC                   | 45 A / 500 VDC            |           |          |
|                 | 30 HP @ 460 VAC                   | 52 A / 500 VDC            |           |          |
|                 | 40 HP @ 460 VAC                   | 73 A / 500 VDC            |           |          |
|                 | 50 HP @ 460 VAC                   | 86 A / 500 VDC            |           |          |
| 60 HP @ 460 VAC | 100 A / 500 VDC                   |                           |           |          |
| 705310-150A     | 40 HP @ 230 VAC                   | 146 A / 240 VDC           | VA = 900  | VA = 55  |
|                 | 50 HP @ 230 VAC                   | 180 A / 240 VDC           |           |          |
|                 | 60 HP @ 230 VAC                   | 218 A / 240 VDC           |           |          |
|                 | 75 HP @ 460 VAC                   | 129 A / 500 VDC           |           |          |
|                 | 100 HP @ 460 VAC                  | 167 A / 500 VDC           |           |          |
|                 | 125 HP @ 460 VAC                  | 207 A / 500 VDC           |           |          |
| 705310-160A     | 75 HP @ 230 VAC                   | 265 A / 240 VDC           | VA = 900  | VA = 55  |
|                 | 150 HP @ 460 VAC                  | 250 A / 500 VDC           |           |          |
| 705310-170A     | 100 HP @ 230 VAC                  | 360 A / 240 VDC           | VA = 1200 | VA = 70  |
|                 | 200 HP @ 460 VAC                  | 330 A / 500 VDC           |           |          |
| 705310-180A     | 125 HP @ 230 VAC                  | 434 A / 240 VDC           | VA = 2900 | VA = 105 |
|                 | 150 HP @ 230 VAC                  | 521 A / 240 VDC           |           |          |
|                 | 250 HP @ 460 VAC                  | 412 A / 500 VDC           |           |          |
|                 | 300 HP @ 460 VAC                  | 495 A / 500 VDC           |           |          |

[www.rockwellautomation.com](http://www.rockwellautomation.com)

---

**Motors, Drives and Power Transmission Solutions**

Americas: Rockwell Automation, 6040 Ponders Court, Greenville, SC 29615-4617 USA, Tel: (1) 864.297.4800, Fax: (1) 864.281.2433

Europe/Middle East/Africa: Rockwell Automation, Herman-Heinrich-Gossen-Strasse 3, 50858 Köln, Germany, Tel: 49 (0) 2234 379410, Fax: 49 (0) 2234 3794164

Asia Pacific: Rockwell Automation, 55 Newton Road, #11-01/02 Revenue House, Singapore 307987, Tel: (65) 6356 9077, Fax: (65) 6356 9011