

250 Amp and 400 Amp AC Line Disconnect Kits for FlexPak 3000 and WebPak 3000 Digital DC Drives

40 to 75 HP @ 230 VAC, 75 to 150 HP @ 460 VAC, 265 A @ 380 / 415 VAC

M/N 901FK1102, 901FK1112, 901FK1202, 901FK1212

Instruction Manual D2-3395-1



ATTENTION: Only qualified personnel familiar with the construction and operation of this equipment and the hazards involved should install, adjust, operate, and/or service this equipment. Read and understand this manual in its entirety before proceeding. Failure to observe this precaution could result in severe bodily injury or loss of life.

ATTENTION: The user is responsible for conforming with all applicable local, national, and international codes. Failure to observe this precaution could result in damage to, or destruction of, the equipment.

Product Description

This instruction manual describes optional AC input line disconnect kits that can be installed on FlexPak™ 3000 and WebPak™ 3000 Digital DC drives (40 to 75 HP @ 230 VAC, 75 to 150 HP @ 460 VAC, 265 A @ 380 / 415 VAC). Each kit includes a molded-case switch and mounting hardware. Kits used with NEMA 1 enclosures also include a mounting bracket to provide through-the-door operation of the switch and a locking bracket to allow a locking device to be used.

The kits provide a positive disconnect of all AC input leads for the FlexPak 3000 and WebPak 3000 drives. The 40-60 / 75-125 HP @ 230 / 460 VAC disconnect is rated for 250 amps at 600 VAC. The 75 / 150 HP @ 230 / 460 VAC disconnect is rated for 400 amps at 600 VAC. To comply with NEC codes, do not use either disconnect for more than 85% of its rated amps.

A yellow test button on the front of the switch (at the lower right or lower left) can be used to check the switch's mechanical operation and for quick disconnect. When pressed, the test button immediately trips the switch open. The test button is not accessible when the switch is mounted in a NEMA 1 enclosure.

Verifying the Kit Model Number Matches the Drive

The disconnect kits are rated for use with Reliance™ FlexPak 3000 and WebPak 3000 drives as shown in table 1. To ensure a kit is properly rated for your application, use it only with Reliance FlexPak 3000 and WebPak 3000 drives and only as listed in the table.

Kit Model Number	Current Rating @ 40° C	Corresponding Drive Horsepower/Voltage Rating	Mounting
901FK1102	250 Amp	40-60 / 75-125 HP @ 230 / 460 VAC	Chassis
901FK1112	250 Amp	40-60 / 75 -125 HP @ 230 / 460 VAC	NEMA 1
901FK1202	400 Amp	75 / 150 HP @ 230 / 460 VAC, 265 A @380 / 415 VAC	Chassis
901FK1212	400 Amp	75 / 150 HP @ 230 / 460 VAC, 265 A @380 / 415 VAC	NEMA 1

Checking the Contents of the Kit

Tables 2 and 3 list the contents of the AC Line Disconnect kits.

Models 901FK1102 (Chassis) and 901FK1112 (NEMA 1)				
Item Number	Description	Quantity		Reliance Part Number
		901FK1102	901FK1112	
1	250 A Disconnect Switch	1	1	65242-200ZSX
2	Disconnect Switch Panel	1	1	802274-218R
3	Lift Bracket	–	1	610274-55S
4	Locking Bracket	–	2	610274-40A
6A	Bus Bar - Center	1	–	610274-264A
		–	1	610274-262A
6B	Bus Bar - Left & Right	2	–	610274-266A
		–	2	610274-263A
7	M6 x 10 Self-tapping Screw	3	9	419062-100PJG
8	M5 x 80 SHCS	4	–	419062-10AHY
	M5 x 90 SHCS	–	4	419062-10AHZ
9	M5 Lockwasher	4	4	419064-100SH
13	¼-20 x .75 Machine Screw	3	3	601742-8H
14	¼" Lockwasher	3	3	601748-3J
15	¼" Flat Washer	3	3	601748-1E
16	Label	1	1	410266-17B
17	Insulator	1	1	77800-100RG

Models 901FK1202 (Chassis) and 901FK1212 (NEMA 1)				
Item Number	Description	Quantity		Reliance Part Number
		901FK1202	901FK1212	
1	400 A Disconnect Switch	1	1	65242-300FSX
2	Disconnect Switch Panel	1	1	802274-218R
3	Lift Bracket	–	1	610274-54S
4A	Left Lock Bracket	–	1	610274-57A
4B	Right Lock Bracket	–	1	610274-58A
5	Spacer	–	4	610274-56A
6	Bus Bar	3	–	610274-261A
		–	6	610274-260A
7	M6 x 10 Self-tapping Screw	3	9	419062-100PJG
8	M6 x 90 SHCS	4	–	419062-10AJY
	M6 x 120 SHCS	–	4	419062-10AJZ
9	M6 Lockwasher	4	4	419064-100SJ
13	3/8-16 x .75 Hex Head Cap Screw	3	3	601741-4A
14	3/8" Lockwasher	3	3	601748-3L
15	3/8" Flat Washer	3	3	601748-1G
16	Label	1	–	410267-3A
		–	1	610274-67A
17	Insulator	1	1	77800-100RH

Installation

	<p>ATTENTION: Do not install modification kits with power applied to the drive. Disconnect, tag, and lock out incoming power before attempting such installation. Failure to observe this precaution could result in severe bodily injury or loss of life.</p>
---	---

Refer to the appropriate figure while performing the installation:

- For M/N 901FK1102, see figures 1 and 2.
- For M/N 901FK1112, see figures 1 and 3.
- For M/N 901FK1202, see figures 1 and 4.
- For M/N 901FK1212, see figures 1 and 5.

Note: On the figures, the number in the circle refers to the [Item Number] in the installation procedure.

INSTALLATION NOTE: This procedure assumes that the drive is wired and operational, and that incoming power is connected to the drive at inline fuse terminals 181, 182, and 183. Kit installation consists of disconnecting terminals 181, 182, and 183 from incoming power and connecting them to the load side of the AC line disconnect. You then connect incoming power to the line side of the AC line disconnect. Finally, you will label the line side of the AC line disconnect as terminals 81, 82, and 83.

Step 1. Turn off, lock out, and tag power to the drive. For chassis mounted kits, proceed to step 3. For NEMA 1 kits, continue to step 2.

- Step 2. **NEMA 1 kits only:** Remove the drive's plastic cover, and then remove the disconnect hole plug from the cover.
- Step 3. Refer to figure 1, View A for steps 3 through 6. Flip down the plastic line fuse cover. It is held in place over the fuses by a hook and loop fastener.
- Step 4. Disconnect the incoming power lines from the drive. Save the M10 fasteners.
- Step 5. Remove the plastic auxiliary chassis cover by removing the two M5 screws on the right side of the motor terminal panel and removing the two M6 screws on the right side of the auxiliary chassis. Discard the plastic cover.
- Step 6. Refer to the appropriate Side View and Detail A in figures 2 through 5. Install the bus bars [Item 6] on terminals 181, 182, and 183, using the M10 fasteners removed in step 4. Note: *On M/N 901FK1212 only, two stacked bus bars are used on each terminal.*
- Step 7. Refer to figure 1, View B. Install the disconnect switch panel [Item 2] in the front of the auxiliary chassis enclosure, using the M5 fasteners removed in step 5. Tighten these fasteners first. Then attach the panel to the auxiliary chassis using the three (3) M6 screws [Item 7].

For chassis mounted kits, proceed to step 9. For NEMA 1 kits, continue to step 8.

- Step 8. **NEMA 1 kits only:** Refer to the appropriate End View in figures 2 through 5. Install the lift bracket [Item 3] on the disconnect switch panel [Item 2] using six (6) M6 self-tapping screws [Item 7]. When mounted properly, the mounting holes on the lift bracket are directly over the mounting holes on the disconnect switch panel.
- Step 9. Mount the disconnect switch.
- M/N 901FK1112**
- Refer to figure 3. Place the insulator [Item 17] under the disconnect switch. Mount the disconnect switch and the lock plates [Items 1 and 4] to the lift plate [Item 3] with M5 fasteners [Items 8 and 9].
 - Apply the label [Item 16] to the top front of the lift plate as shown in figure 1, View B and figure 3.
 - Refer to figure 3. Use 1/4" fasteners [Items 13, 14, and 15] to connect the bus bars installed on terminals 181, 182, and 183 in step 6 to the disconnect switch's load terminals.

M/N 901FK1212

- Remove the top and bottom terminal covers from the disconnect switch and discard them.
- Refer to the figure 5. Place the insulator [Item 17] under the disconnect switch. Mount the disconnect switch, the label, the lock plates and the insulator blocks [Items 1, 16, 4A, 4B, and 5] to the lift plate [Item 3] with M6 fasteners [Items 8 and 9]. Note that there is a right lock plate and a left lock plate.
- Refer to figure 5. Use 3/8" fasteners [Items 13, 14, and 15] to connect the bus bars installed on terminals 181, 182, and 183 in step 6 to the disconnect switch's load terminals.

M/N 901FK1102 or M/N 901FK1202:

- Refer to figure 2 or figure 4. Place the insulator [Item 17] under the disconnect switch. Mount the disconnect switch [Item 1] to the disconnect switch panel [Item 2] with the M5 or M6 fasteners supplied [Items 8 and 9]. Note that for M/N 901FK1202, the lug covers must be removed in order to access the mounting holes.

- b. Apply the label [Item 16] at the top front of the disconnect, as shown in figure 1, View B.
- c. Refer to figure 2 or figure 4. Connect the bus bars installed on terminals 181, 182, and 183 in step 6 to the disconnect switch's load terminals. Use 1/4" fasteners for the 250 A disconnect or 3/8" fasteners for the 400 A disconnect [Items 13, 14, and 15].

Step 10. Torque the fasteners on the bus bars to the values listed in table 4.

Fastener Size	Maximum Torque
1/4"	7.46 Nm (66 in-lb)
3/8"	26.66 Nm (236 in-lb)
M10	22.59 Nm (200 in-lb)

Step 11. Connect the power lines to the line side of the disconnect, and torque to the recommended values listed on the standard lug data on the face of the disconnect. For M/N 901FK1202, replace the lug covers that were removed in step 9a.

Step 12. Flip the line fuse cover up and press it against the hook and loop fastener to hold it in position over the fuses. For chassis-mounted kits, proceed to step 14. For NEMA 1 kits, continue to step 13.

Step 13. **NEMA 1 kits only:** Reinstall the drive's plastic cover with the disconnect lock plates [Item 4] protruding through the hole in the cover.

Step 14. Set the line disconnect to the "ON" position. To set the disconnect, the manual switch must first be clicked into position 0 (down) and then moved to position 1 (up).

Step 15. Remove the lockout and tag from the power to the drive.

Step 16. Turn on power to the drive.

Step 17. Test the installation by setting the line disconnect to "OFF" (position 0) and measuring the voltage at terminals 181, 182, and 183. All three terminals should be at approximately zero volts (0 VAC). After verifying correct installation, set the line disconnect to "ON."

Kit installation is now complete.

Motor Terminal Panel

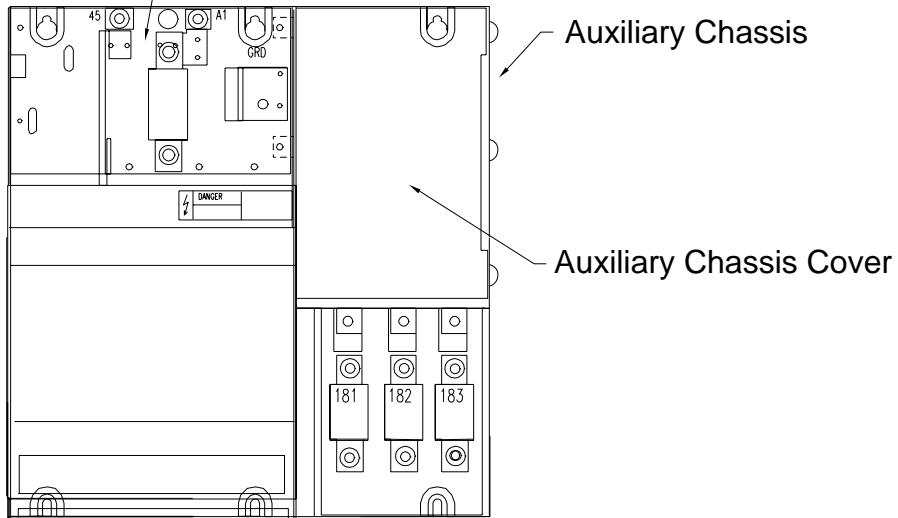

Auxiliary Chassis

Auxiliary Chassis Cover

View A

AC Line Disconnect Panel

M5 Screws

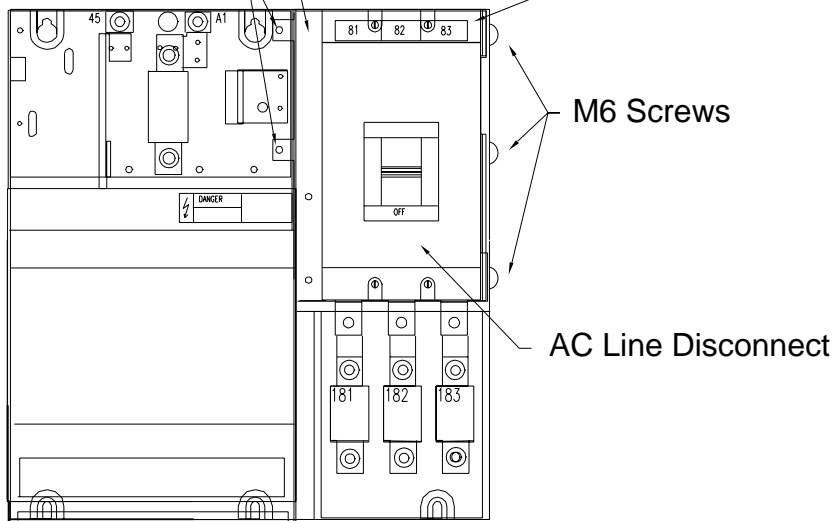

Label

M6 Screws

AC Line Disconnect

View B

Figure 1 – AC Line Disconnect Mounting Location

Figure 2 – 250 Amp Chassis-Mount Kit (M/N 901FK1102)

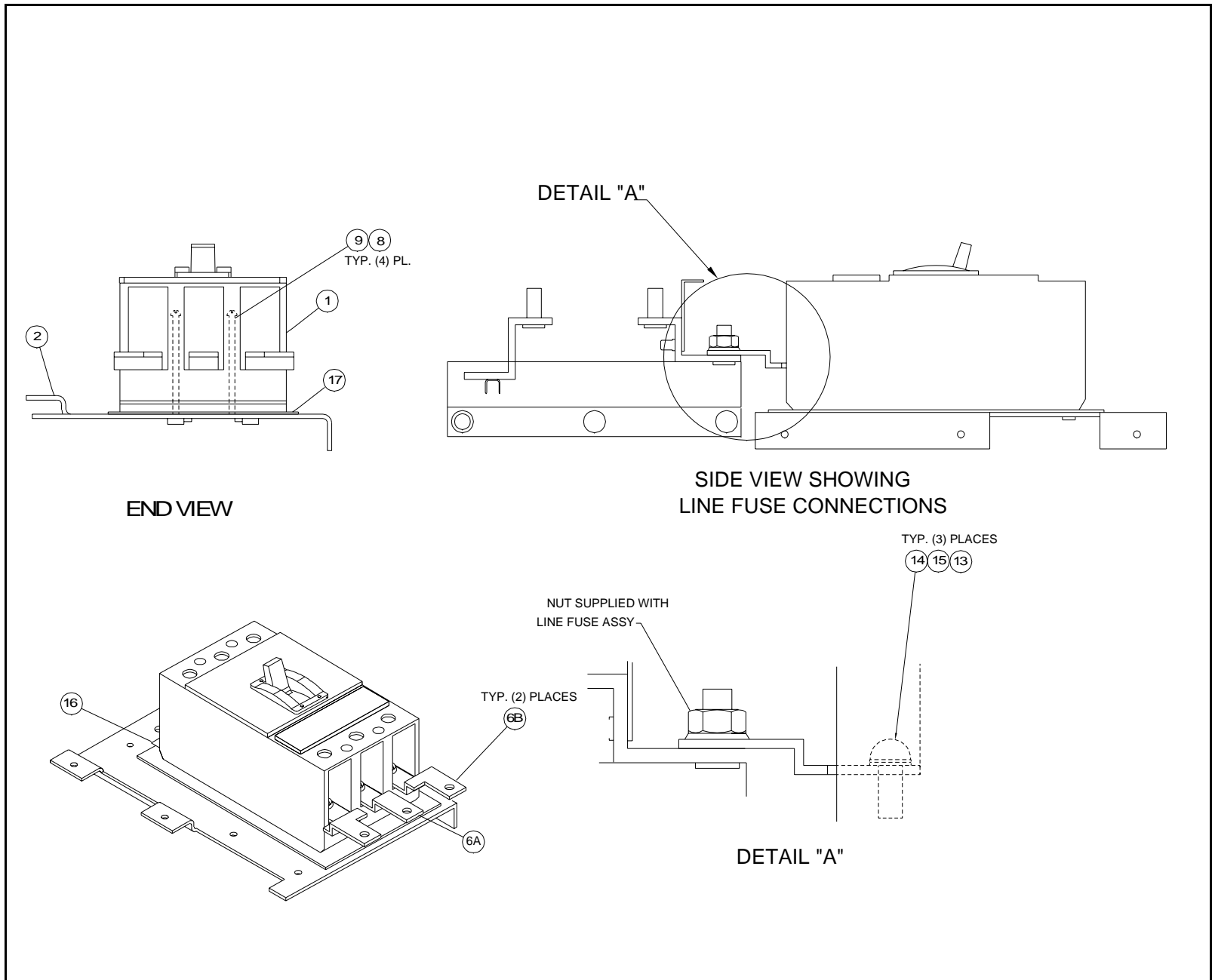

Figure 3 – 250 Amp NEMA 1 Kit (M/N 901FK1112)

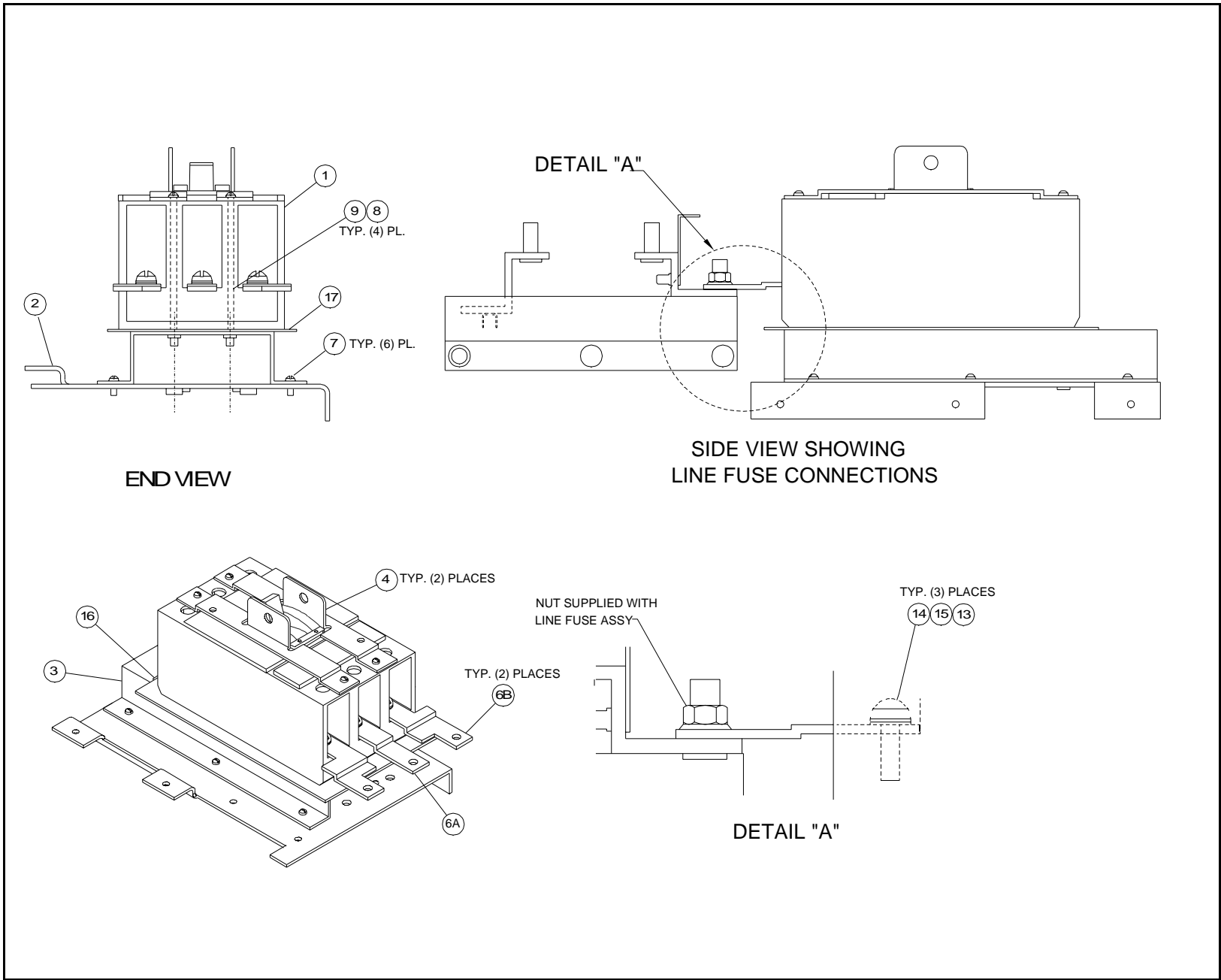
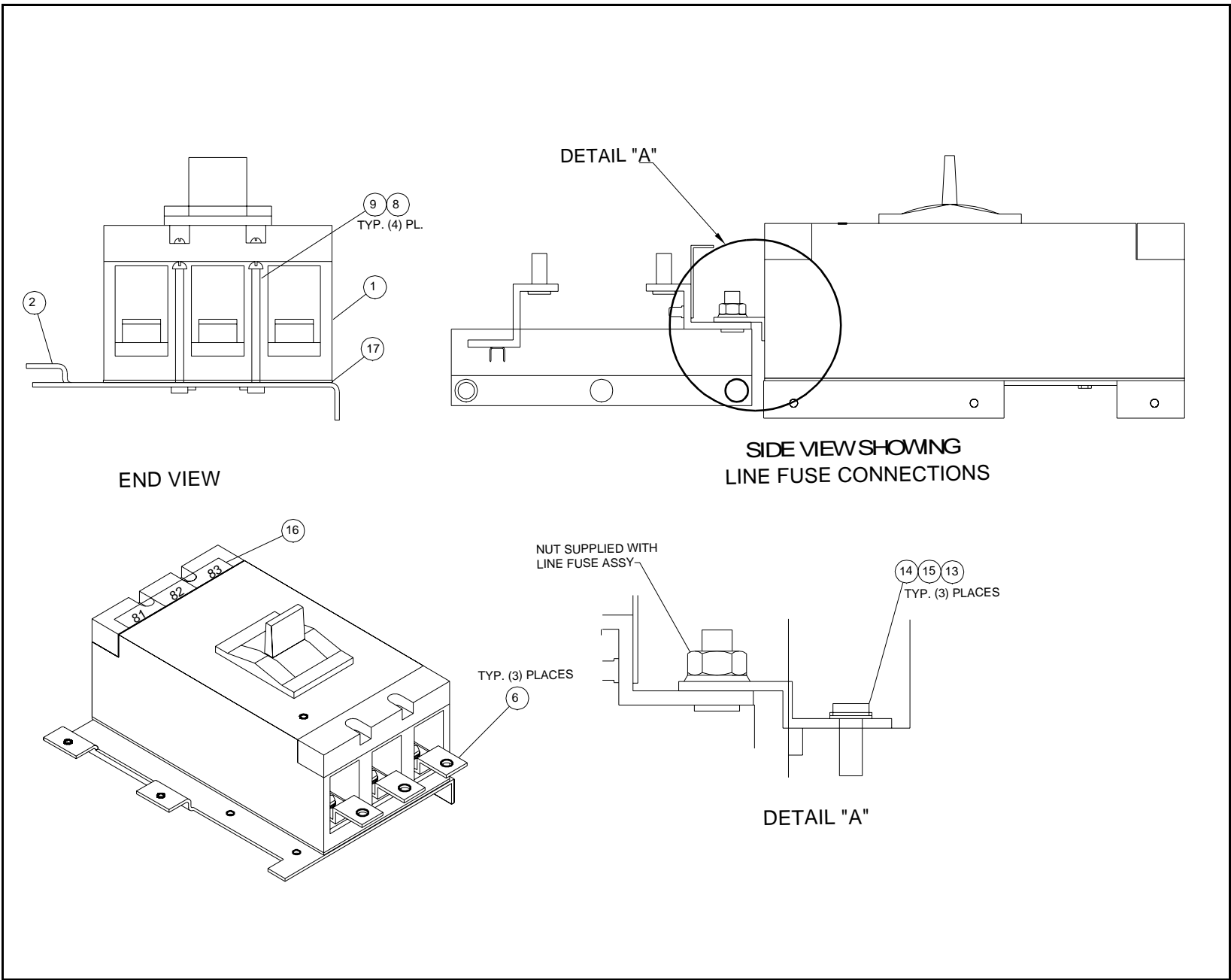

Figure 4 – 400 Amp Chassis-Mount Kit (M/N 901FK1202)



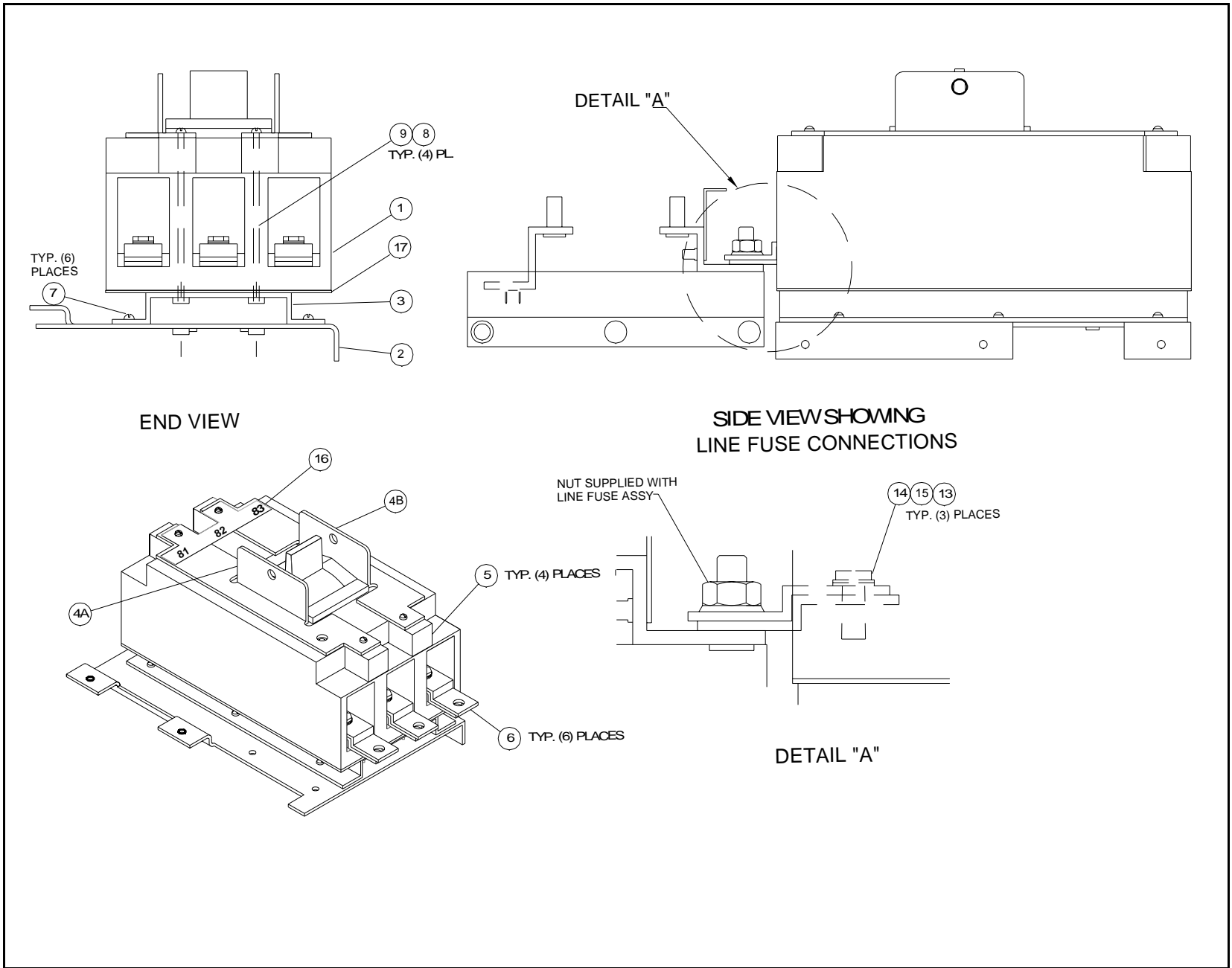

Figure 5 - 400 Amp NEMA 1 Kit (MIN 901FK1212)

Reach us now at www.rockwellautomation.com

Wherever you need us, Rockwell Automation brings together leading brands in industrial automation including Allen-Bradley controls, Reliance Electric power transmission products, Dodge mechanical power transmission components, and Rockwell Software. Rockwell Automation's unique, flexible approach to helping customers achieve a competitive advantage is supported by thousands of authorized partners, distributors and system integrators around the world.

Americas Headquarters, 1201 South Second Street, Milwaukee, WI 53204, USA, Tel: (1) 414 382-2000, Fax: (1) 414 382 4444

European Headquarters SA/NV, avenue Herrmann Debroux, 46, 1160 Brussels, Belgium, Tel: (32) 2 663 06 00, Fax: (32) 2 663 06 40

Asia Pacific Headquarters, 27/F Citicorp Centre, 18 Whitfield Road, Causeway Bay, Hong Kong, Tel: (852) 2887 4788, Fax: (852) 2508 1846

Reliance Electric Standard Drives Business, 24800 Tungsten Road, Cleveland, OH 44117, USA, Tel: (1) 888 374 8370, Fax: (216) 266 7095



**Rockwell
Automation**