



**FlexPak 3000
Enhanced Field Supply Kit
Installation Instructions**

M/N 923FK0101 and 923FK0201

Instruction Manual D2-3413-1

Rockwell
Automation

The information in this manual is subject to change without notice.

Throughout this manual, the following notes are used to alert you to safety considerations:



ATTENTION: Identifies information about practices or circumstances that can lead to personal injury or death, property damage, or economic loss.

Important: Identifies information that is critical for successful application and understanding of the product.

The thick black bar shown on the outside margin of this page will be used throughout this instruction manual to signify new or revised text or figures.



ATTENTION: Only qualified personnel familiar with the construction and operation of this equipment and the hazards involved should install, operate, and/or service this equipment. Read and understand this instruction manual in its entirety before proceeding. Failure to observe this precaution could result in severe bodily injury or loss of life.

ATTENTION: The user is responsible for conforming with all applicable local, national, and international codes. Failure to observe this precaution could result in damage to, or destruction of, the equipment.

FlexPak 3000 and Reliance are trademarks of Rockwell Automation.

©2000 Rockwell International Corporation

CONTENTS

Chapter 1	Introduction	
1.1	Related Publications	1-2
1.2	Getting Assistance from Reliance Electric.....	1-2
Chapter 2	Installing the Enhanced Field Supply Kit on 3.0 HP to 60 HP @ 460 VAC (1.5 HP to 30 HP @ 230 VAC) Drives	
2.1	Removing the OIM Cover and Opening the Carrier	2-1
2.2	Removing the Standard Field Supply Board	2-2
2.3	Adjusting the Jumpers on the Enhanced Field Supply Board and the Regulator Board	2-2
2.4	Installing the Enhanced Field Supply Board.....	2-4
2.5	Replacing the Drive Fuses	2-5
2.6	Closing the Carrier and Reinstalling the OIM Cover.....	2-6
2.7	Modifying the Drive Configuration	2-6
Chapter 3	Installing the Enhanced Field Supply Kit on 75 HP to 150 HP @ 460 VAC (40 HP to 75 HP @ 230 VAC) Drives	
3.1	Accessing the Field Supply Board.....	3-2
3.2	Removing the Standard Field Supply Board (75 HP to 125 HP @ 460 VAC / 40 HP to 75 HP @ 230 VAC Drives)	3-2
3.3	Removing the Field Current Regulator Board (150 HP @ 460 VAC / 40 HP to 75 HP @ 230 VAC Drives)	3-3
3.4	Adjusting the Jumpers on the Enhanced Field Supply Board and the Regulator Board	3-4
3.5	Installing the Enhanced Field Supply Board.....	3-4
3.6	Replacing the Drive Fuses	3-5
3.7	Reinstalling the Auxiliary Chassis Cover	3-7
3.8	Reinstalling the AC Disconnect	3-8
3.9	Modifying the Drive Configuration	3-8
Chapter 4	Installing the Enhanced Field Supply Kit on 200 HP to 300 HP @ 460 VAC (100 HP to 150 HP @ 230 VAC) Drives	
4.1	Removing the Field Current Regulator Board	4-1
4.2	Adjusting the Jumpers on the Enhanced Field Supply Board and the Regulator Board	4-2
4.3	Installing the Enhanced Field Supply Board.....	4-3
4.4	Reinstalling the OIM and Its Cover.....	4-3
4.5	Replacing the Drive Fuses	4-3
4.6	Modifying the Drive Configuration	4-4
Chapter 5	Installing the Enhanced Field Supply Kit on 400 HP to 600 HP @ 460 VAC Drives	
5.1	Removing the Drive Cover and Opening the Carrier.....	5-2
5.2	Removing the Field Current Regulator Board	5-2
5.3	Adjusting the Jumpers on the Enhanced Field Supply Board and the Regulator Board	5-3
5.4	Reinstalling the OIM and Cover.....	5-4
5.5	Installing the Enhanced Field Supply Board.....	5-4

5.6	Resecuring the Hinged OIM Mounting Plate.....	5-5
5.7	Replacing the Drive Fuses	5-6
5.8	Reinstalling the Plastic Drive Cover and Reclosing the Steel Door	5-6
5.9	Modifying the Drive Configuration	5-6

Chapter 6 Setting the Field Voltage Trim Jumpers

Chapter 7 Modifying the Drive Configuration

7.1	Parameter 306 (NOMINAL AC LINE FREQUENCY).....	7-1
7.2	Parameter 500 (ENHANCED FLD VOLT ADJ).....	7-1
7.3	Examples for Setting Parameters 306 and 500	7-2
7.4	Parameter 501 (FIELD ECONOMY DELAY)	7-4

List of Figures

Figure 1.1 – Enhanced Field Supply Board.....	1-2
Figure 2.1 – Removing the Standard Field Supply Board (3 HP to 60 HP @ 460 VAC Drives)	2-2
Figure 2.2 – Setting the Jumpers on the Enhanced Field Supply Board.....	2-3
Figure 2.3 – Setting the Jumpers on the Regulator Board	2-3
Figure 2.4 – Installing the Enhanced Field Supply Board (3 HP to 60 HP @ 460 VAC Drives)	2-4
Figure 2.5 – Field Fuse Location (3 HP to 60 HP @ 460 VAC Drives).....	2-5
Figure 2.6 – Attaching Replacement Drive Fuse Labels (3 HP to 60 HP @ 460 VAC Drives)	2-5
Figure 3.1 – Removing the Field Supply Board (75 HP to 125 HP @ 460 VAC Drives)	3-3
Figure 3.2 – Installing the Enhanced Field Supply Board (75 HP to 150 HP @ 460 VAC Drives)	3-5
Figure 3.3 – Field Fuse Location (75 HP to 150 HP @ 460 VAC Drives).....	3-6
Figure 3.4 – Attaching Replacement Drive Fuse Labels (75 HP to 150 HP @ 460 VAC Drives)	3-7
Figure 4.1 – Removing the Field Current Regulator Board (200 HP to 300 HP @ 460 VAC Drives)	4-2
Figure 5.1 – Removing the Field Current Regulator Board (400 HP to 600 HP @ 460 VAC Drives)	5-3
Figure 5.2 – Location of Field Current Regulator Connectors	5-3
Figure 5.3 – Mounting the Enhanced Field Supply.....	5-5

List of Tables

Table 1.1 – Current Ratings and Model Numbers for the Enhanced Field Supply Kit.....	1-1
Table 6.1 – Setting the Enhanced Field Supply Board and the Regulator Board Jumpers	6-1
Table 7.1 – Parameter 500 Values When Jumpers are Set to B–C	7-3
Table 7.2 – Parameter 500 Values When Jumpers are Set to A–C	7-3

CHAPTER 1

Introduction

This instruction manual describes how to install and configure the optional Enhanced Field Supply kit used by FlexPak 3000 DC Drives. The kit can be installed in FlexPak 3000 drives rated at 3 HP to 600 HP @ 460 VAC (1.5 HP to 150 HP @ 230 VAC). It replaces the Standard Field Supply (P/N 610273-14R) already installed on 3 HP to 125 HP @ 460 VAC (1.5 HP to 60 HP @ 230 VAC) drives and the Field Current Regulator (P/N 707973-10R, S, or T on 150 HP to 600 HP @ 460 VAC (75 HP to 150 HP @ 230 VAC) drives.

When installed in your drive, the Enhanced Field Supply kit provides you with greater control over the drive's field output, allowing you to match the rated field voltage of the DC motor required for your application. For example, the Enhanced Field Supply enables the drive to provide a 240 volt field to a motor from a 230 volt line. (See chapter 6, Modifying the Drive Configuration, for more information.)

Two versions of the Enhanced Field Supply kit are available. They differ according to the current rating. Each kit is supplied as an assembly that includes the Enhanced Field Supply board and an attached wiring harness, as well as replacement fuses, fuse labels, and mounting hardware. See figure 1.1 for an illustration of the Enhanced Field Supply board. Enhanced Field Supply kit contents are shown in table 1.1.

Table 1.1 – Current Ratings and Model Numbers for the Enhanced Field Supply Kit

Kit Model Number	Current Rating	Part Number	Description	Quantity
923FK0101	10	707973-15S	Enhanced Field Supply Board	1
		64676-30M	Field Input Fuses (25 A, 600 V)	3
		179540	Fuse Rating Label	4
		D2-3413-1	Instruction Manual	1
923FK0201	20	707973-15R	Enhanced Field Supply Board	1
		64676-30M	Field Input Fuses (25 A, 600 V)	3
		179540	Fuse Rating Label	4
		D2-3413-1	Instruction Manual	1

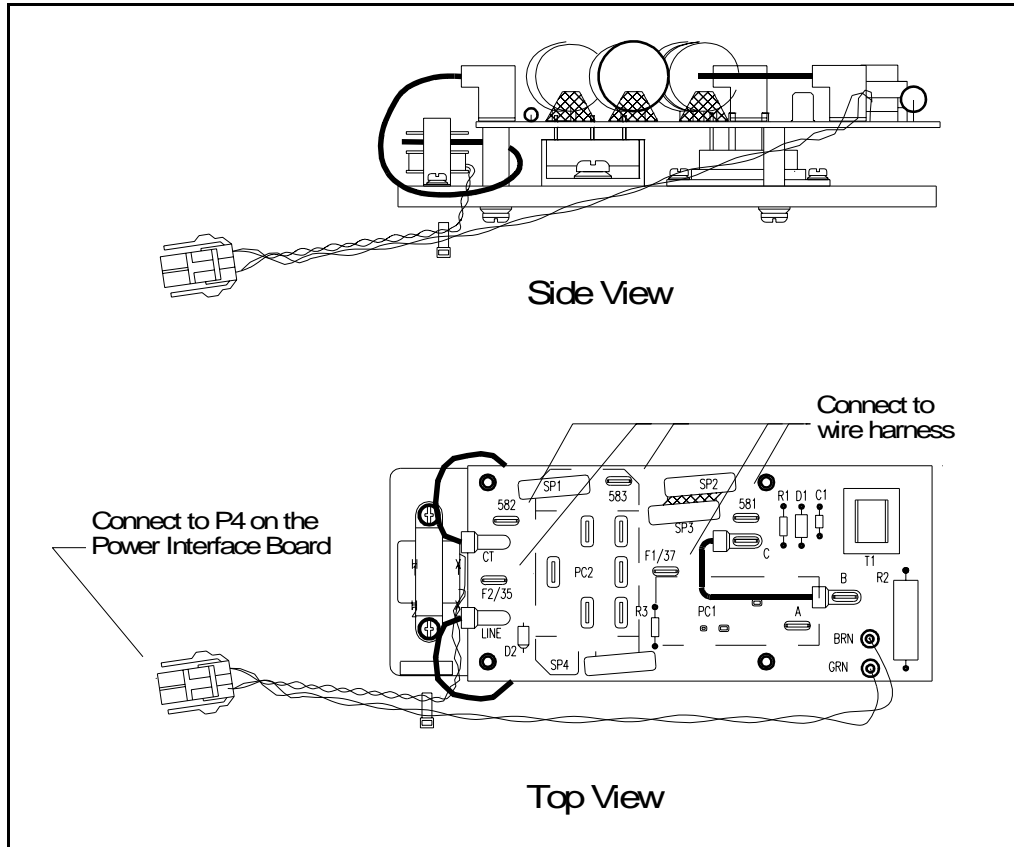

Figure 1.1 – Enhanced Field Supply Board

1.1 Related Publications

This manual describes the Enhanced Field Supply kit and its associated FlexPak 3000 software parameters. You will also need the FlexPak 3000 DC Drive instruction manuals, which describes the drive hardware and software.

1.2 Getting Assistance from Reliance Electric

If you have any questions or problems with the products described in this instruction manual, contact your local Reliance Electric sales office. For technical assistance, call 1-800-726-8112.

Installing the Enhanced Field Supply Kit on 3.0 HP to 60 HP @ 460 VAC (1.5 HP to 30 HP @ 230 VAC) Drives



ATTENTION: Only qualified personnel familiar with the construction and operation of this equipment and the hazards involved should install, operate, and/or service this equipment. Read and understand this instruction manual in its entirety before proceeding. Failure to observe this precaution could result in severe bodily injury or loss of life.

ATTENTION: Do not install modification kits with power applied to the drive. Disconnect and lockout incoming power before attempting such installation. Failure to observe this precaution could result in severe bodily injury or loss of life.

Installing the Enhanced Field Supply kit on 3.0 HP to 60 HP @ 460 VAC (1.5 HP to 30 HP @ 230 VAC) drives requires completing the following steps. Removing the OIM cover and opening the carrier

- Removing the Standard Field Supply board
- Setting the jumpers on the Enhanced Field Supply board and the Regulator board
- Installing the Enhanced Field Supply board
- Replacing the drive fuses
- Closing the carrier and reinstalling the OIM cover
- Modifying the drive configuration

These steps are described in detail below.

When you have finished installing the kit, adjust the required drive parameters as described in chapter 7 before using the drive.

2.1 Removing the OIM Cover and Opening the Carrier



ATTENTION: The drive contains printed circuit boards that are static sensitive. An anti-static wrist band should be worn by any person who touches the drive's components, connectors or leads. Erratic machine operation and damage to, or destruction of, equipment may result if this procedure is not followed. Failure to observe this precaution may result in bodily injury.

Step 1. Turn off, lockout, and tag power to the drive.

- Step 2. Loosen the OIM cover retaining screws and remove the cover.
- Step 3. Loosen the captive screw at the upper right corner of the drive's Regulator board carrier and swing it open.

2.2 Removing the Standard Field Supply Board

- Step 1. Locate the Standard Field Supply board in the drive. See figure 2.1.
- Step 2. Disconnect the drive's wire harness connections from the existing field supply board's 581, 582, 583, F2/35 and F1/37 spade connectors.
- Step 3. Follow the field supply board's wire harness to the P4 connector on the Power Interface board. Unplug the harness from the P4 connector.
- Step 4. Locate the field supply's four mounting screws on the outside of the drive's right side panel.
- Step 5. Remove the four mounting screws from the outside of the drive and remove the field supply board.

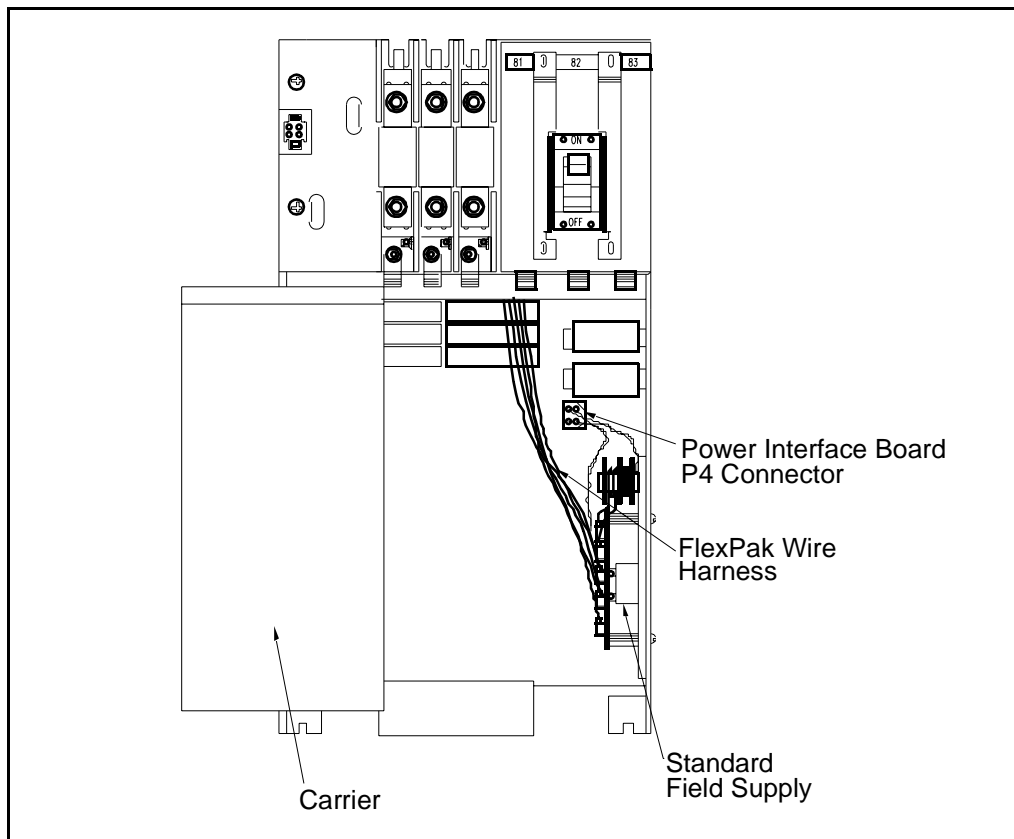

Figure 2.1 – Removing the Standard Field Supply Board (3 HP to 60 HP @ 460 VAC Drives)

2.3 Adjusting the Jumpers on the Enhanced Field Supply Board and the Regulator Board

- Step 1. Refer to chapter 6 to determine the correct field output range jumpering for your application.

Important: All Enhanced Field Supply boards are shipped with the wire jumper connecting pins "B" and "C". The actual field output voltage, once the range is jumper selected, is adjusted through the drive's OIM (Operator Interface Module).

- Step 2. If necessary, move the Enhanced Field Supply board's wire jumper to select an output voltage range. (pin "A" connected to pin "C" or pin "B" connected to pin "C".) See figure 2.2.
- Step 3. Remove the four (4) screws securing the OIM to the Regulator board carrier and move the OIM to gain access to the drive's Regulator board. Do not attempt to remove the OIM completely. See figure 2.3.
- Step 4. Locate Regulator board jumper J21 (FIELD SUPPLY JUMPER).
- Step 5. Move regulator board jumper J21 so that it matches the jumper setting of the Enhanced Field Supply board (A-C or B-C).
- Step 6. Reinstall the OIM on the Regulator board carrier.

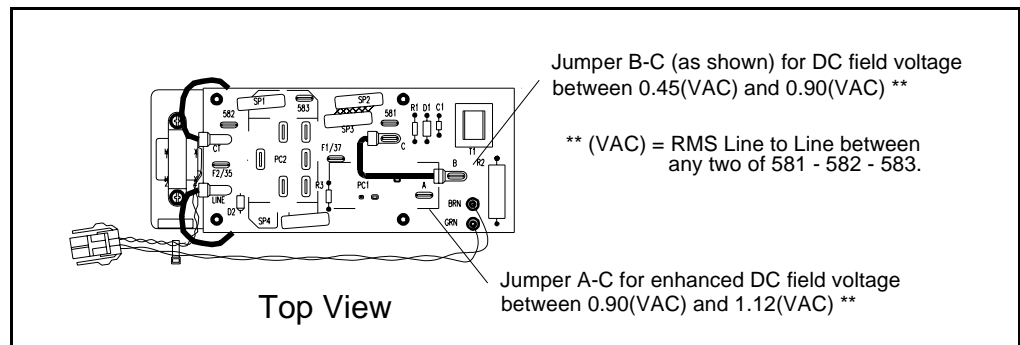

Figure 2.2 – Setting the Jumpers on the Enhanced Field Supply Board

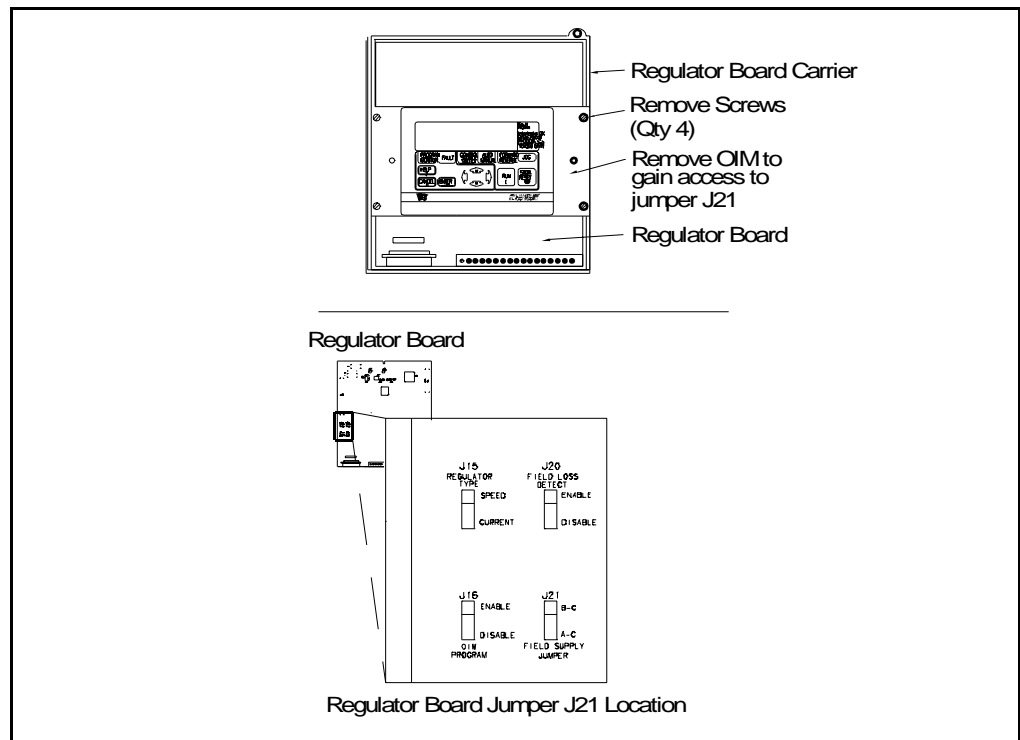

Figure 2.3 – Setting the Jumpers on the Regulator Board

2.4 Installing the Enhanced Field Supply Board

- Step 1. Remove the four mounting screws from the back of the Enhanced Field Supply board.
- Step 2. Working from the inside of the drive, align the Enhanced Field Supply board's mounting holes with the mounting holes on the drive's right side panel. See figure 2.4.
- Step 3. Working from the outside of the drive, insert one of the mounting screws (removed in step 1 through one of the mounting holes on the drive's right side panel and into the corresponding mounting hole in the Enhanced Field Supply's board. Tighten the screw to hold the board in place.
- Step 4. Repeat step 3 for the remaining three mounting screws.
- Step 5. Connect the drive's wire harness to the Enhanced Field Supply board's 581, 582, 583, F2/35, and F1/37 spade connectors. See figure 1.1 for the location of the connectors.
- Step 6. Plug the Enhanced Field Supply's harness connector P4 into connector P4 on the drive's Power Interface board. See figure 2.1.

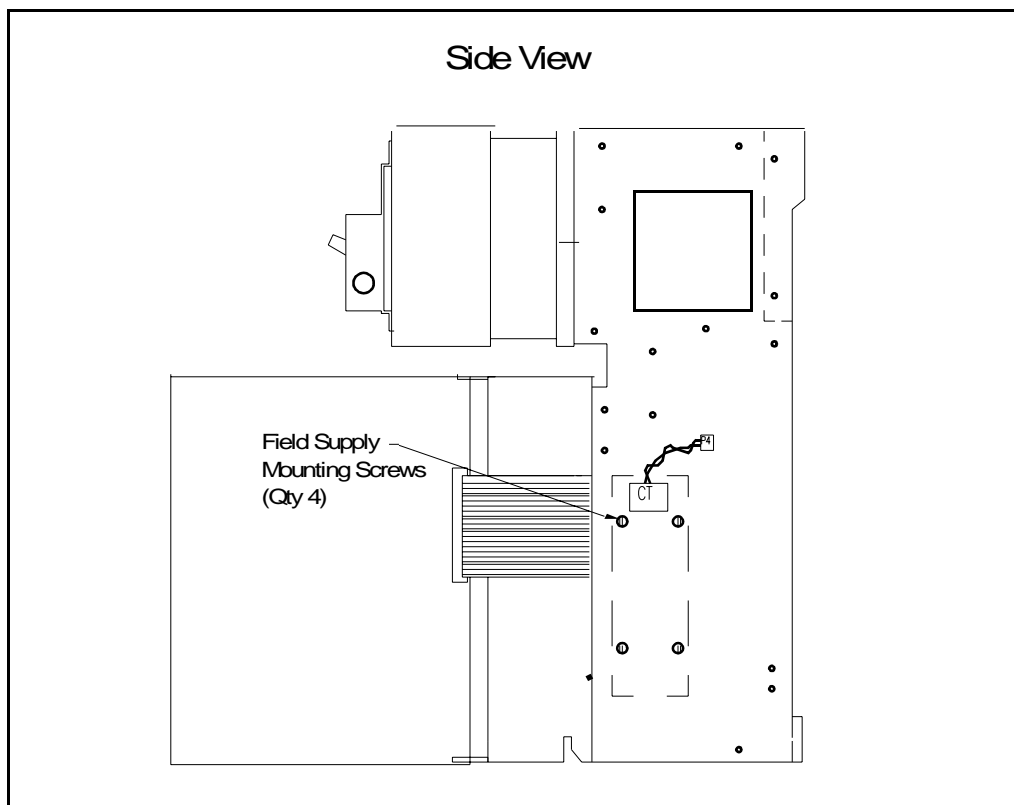

Figure 2.4 – Installing the Enhanced Field Supply Board (3 HP to 60 HP @ 460 VAC Drives)

2.5 Replacing the Drive Fuses

- Step 1. Remove the three fuses labeled 6FU, 7FU, and 8FU from the drive's fuse block. See figure 2.5.
- Step 2. Install the three provided 25 A, 600 V fuses (P/N 64676-30M) in the fuse block in positions 6FU, 7FU, and 8FU.
- Step 3. Locate the replacement fuse table on the back of the carrier. Attach one of the adhesive fuse rating labels (P/N 179540) over each of the places indicated in figure 2.6.

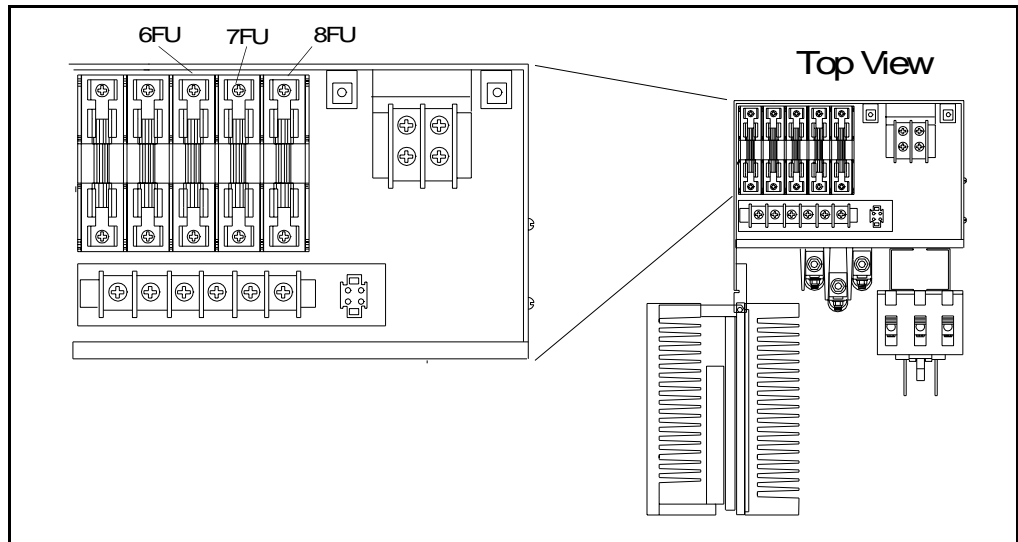

Figure 2.5 – Field Fuse Location (3 HP to 60 HP @ 460 VAC Drives)

REPLACE FUSES WITH:				
HP @ 230VAC	11FU BRUSH type XL70F	1FU 2FU 3FU BRUSH type XL50F	4FU 5FU LITTELFUSE type KLDR	6FU 7FU 8FU CLASS CC non-time delay
1.5	700V 15A	500V 40A	600V 1.5A	600V 15A
2	700V 20A			
3	700V 25A			
5	700V 35A			
7.5	700V 40A			
10	700V 50A			
15	700V 70A	500V 90A		
HP @ 460VAC	11FU BRUSH type XL70F	1FU 2FU 3FU BRUSH type XL50F	4FU 5FU LITTELFUSE type KLDR	6FU 7FU 8FU CLASS CC non-time delay
3	700V 15A	500V 40A	600V .6A	600V 15A
5	700V 20A			
7.5	700V 25A			
10	700V 35A			
15	700V 40A			
20	700V 50A			
25	700V 60A	500V 80A		
30	700V 70A	500V 90A		

802273-34B

600V 25A

Figure 2.6 – Attaching Replacement Drive Fuse Labels (3 HP to 60 HP @ 460 VAC Drives)

2.6 Closing the Carrier and Reinstalling the OIM Cover

- Step 1. Close the Regulator board carrier and secure it in place with its captive screw.
- Step 2. Reinstall the OIM cover and secure it in place with its screws.
- Step 3. Reconnect power to the drive. Hardware installation is complete.
- Step 4. Remove the lockout and tag.
- Step 5. Turn on power to the drive.

2.7 Modifying the Drive Configuration

Go to chapter 7 and follow the procedures described there to set the parameters for the Enhanced Field Supply kit.

Installing the Enhanced Field Supply Kit on 75 HP to 150 HP @ 460 VAC (40 HP to 75 HP @ 230 VAC) Drives



ATTENTION: Only qualified personnel familiar with the construction and operation of this equipment and the hazards involved should install, operate, and/or service this equipment. Read and understand this instruction manual in its entirety before proceeding. Failure to observe this precaution could result in severe bodily injury or loss of life.

ATTENTION: The drive is at line voltage when connected to incoming AC power. Disconnect, tag and lockout all incoming power to the drive before performing the following procedure. Failure to observe this precaution could result in severe bodily injury or loss of life.

Installing the Enhanced Field Supply kit on 75 HP to 150 HP @ 460 VAC (40 HP to 75 HP @ 230 VAC) drives requires completing the following steps. Accessing the Field Supply board

- Removing the Standard Field Supply board
- Removing the Field Current Regulator board
- Adjusting the Jumpers on the Enhanced Field Supply board and the Regulator board
- Installing the Enhanced Field Supply board
- Replacing the drive fuses
- Reinstalling the auxiliary chassis cover
- Reinstalling the AC Disconnect
- Modifying the drive configuration

These steps are described in detail below.

When you have finished installing the kit, adjust the required drive parameters as described in chapter 7 before using the drive.

3.1 Accessing the Field Supply Board



ATTENTION: The drive contains printed circuit boards that are static sensitive. An anti-static wrist band should be worn by any person who touches the drive's components, connectors or leads. Erratic machine operation and damage to, or destruction of, equipment may result if this procedure is not followed. Failure to observe this precaution may result in bodily injury.

Step 1. Turn off, lockout, and tag power to the drive.

If the drive is equipped with an AC line disconnect, go to step 5. Otherwise, follow steps 2 through 4.

Step 2. Loosen the two screws at the right side of the motor terminal panel to free the tabs on the auxiliary chassis cover. Do not to remove the screws completely. See figure 3.1.

Step 3. Remove the top and bottom screws fastening the auxiliary chassis cover to the drive's right side panel.

Step 4. Loosen the middle screw that fastens the auxiliary chassis cover/circuit breaker panel to the drive's right side panel. Swing out the auxiliary chassis cover and remove it.

Step 5. If there is enough clearance between the top of the AC disconnect and the roof of the cabinet (drive enclosure), the field supply board can possibly be removed and replaced from the top. This would bypass the procedure of removing the AC disconnect. If you can remove and replace the field supply board from the top and behind the AC disconnect, follow the steps in the next section. If the AC disconnect must be removed for access to the field supply board, refer to instruction manual D2-3395 (for CE-compliant drives) or D2-3315 (non-CE-compliant drives).

3.2 Removing the Standard Field Supply Board (75 HP to 125 HP @ 460 VAC / 40 HP to 75 HP @ 230 VAC Drives)

Step 1. Locate the Standard Field Supply board in the drive. See figure 3.1. If you have an AC disconnect and elected not to remove it, skip to step 4, then return to steps 2 and 3. Otherwise, continue with step 2.

Step 2. Disconnect the drive's wire harness connections from the existing field supply board's 581, 582, 583, F2/35 and F1/37 spade connectors.

Step 3. Disconnect the Standard Field Supply board P4 connector from the S4.

Step 4. Remove the four (4) mounting screws from the outside of the drive's right side panel and remove the Standard Field Supply board from above and behind the AC disconnect.

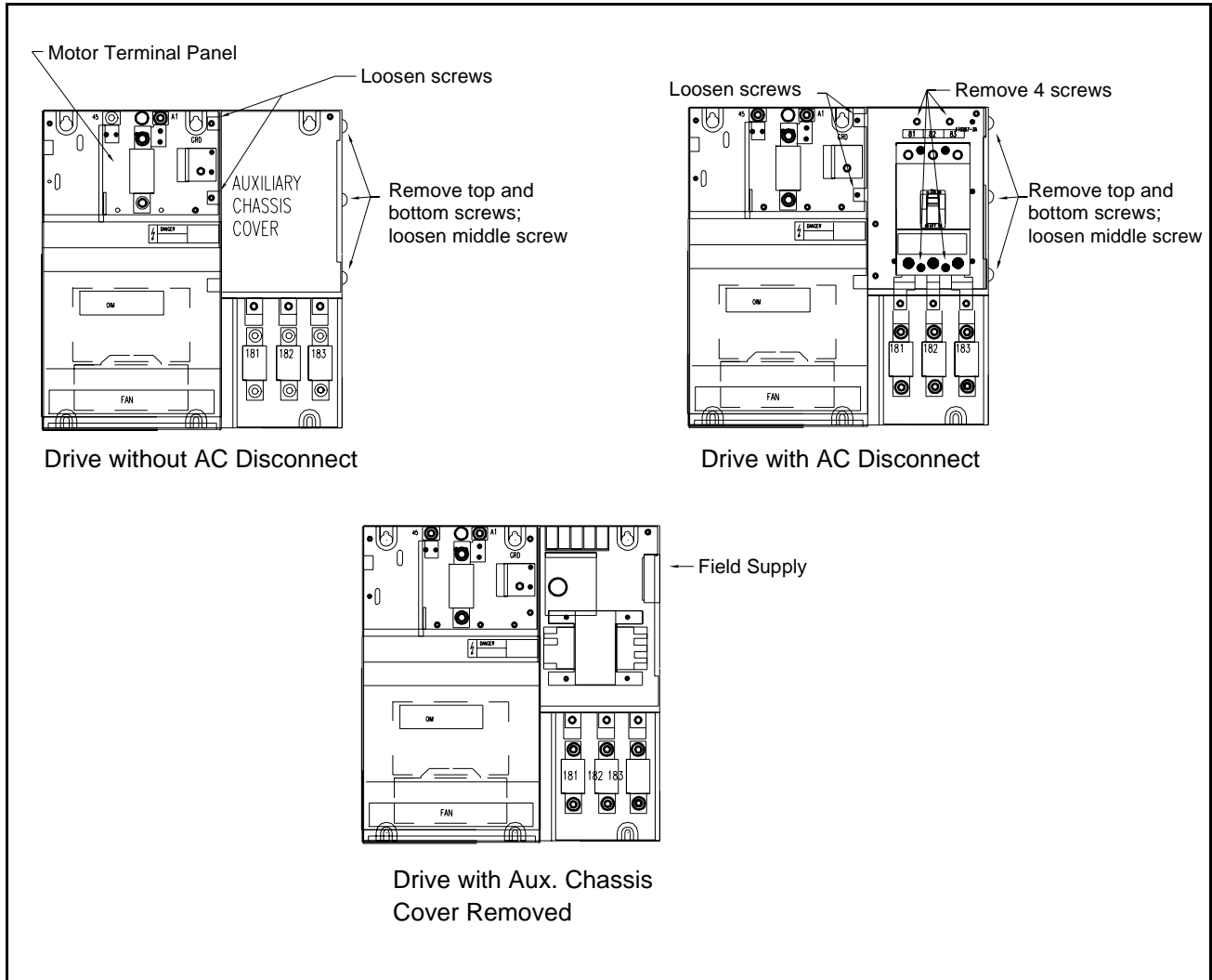

Figure 3.1 – Removing the Field Supply Board (75 HP to 125 HP @ 460 VAC Drives)

3.3 Removing the Field Current Regulator Board (150 HP @ 460 VAC / 40 HP to 75 HP @ 230 VAC Drives)

- Step 1. Locate the Field Current Regulator board in the drive. See figure 3.1.
- Step 2. Disconnect the drive's wire harness connections from the existing field supply board's 581, 582, 583, F2/35 and F1/37 spade connectors.
- Step 3. Disconnect the Field Current Regulator cable assembly (P/N 707973–12R, S, or T) FLD P6 and FLD P3 connectors from the Field Current Regulator board. Also disconnect the opposite end of this cable from J25. Do not remove the cable.
- Step 4. Remove the four (4) mounting screws from the outside of the drive's right side panel and remove the Field Current Regulator board.

3.4 Adjusting the Jumpers on the Enhanced Field Supply Board and the Regulator Board

Step 1. Refer to chapter 6 to determine the correct field output range jumpering for your application.

Important: All Enhanced Field Supply boards are shipped with the wire jumper connecting "B" and "C". The actual field output voltage, once the range is jumper selected, is adjusted through the drive's OIM (Operator Interface Module).

Step 2. If necessary, move the Enhanced Field Supply board's wire jumper to select an output voltage range (pin "A" connected to pin "C" or pin "B" connected to pin "C"). See figure 2.2.

Step 3. Loosen the OIM cover retaining screws and remove the cover.

Step 4. Remove the four (4) screws securing the OIM to the Regulator board carrier and move the OIM to gain access to the drive's Regulator board. See figure 2.3.

Step 5. Locate Regulator board jumper J21 (FIELD SUPPLY JUMPER). See figure 2.3.

Step 6. If necessary, move Regulator board jumper J21 so that it matches the jumper setting of the Enhanced Field Supply board (A-C or B-C).

Step 7. Reinstall the OIM on the Regulator board carrier.

Step 8. Reinstall the OIM cover.

3.5 Installing the Enhanced Field Supply Board

If you have an AC Disconnect, and elected not to remove it, do steps 5 and 6 first. Then return to step 1. If the drive does not have an AC Disconnect, begin with step 1.

Step 1. Remove the four mounting screws from the back of the Enhanced Field Supply board.

Step 2. Working from the inside of the drive, align the Enhanced Field Supply board's mounting holes with the mounting holes on the drive's right side panel. See figure 3.2. Orient the Enhanced Field Supply board so that the end with the transformer points to the front of the panel.

Step 3. Working from the outside of the drive, insert one of the mounting screws (removed in step 1) through one of the mounting holes on the drive's right side panel and into the corresponding mounting hole on the Enhanced Field Supply board. Tighten the screw only enough to hold the board in place.

Step 4. Repeat step 3 for the remaining three mounting screws. Tighten all four screws.

Step 5. Connect the drive's wire harness to the Enhanced Field Supply board's 581, 582, 583, F2/35, and F1/37 spade connectors. See figure 1.1 for the location of the connectors.

Step 6. Plug the Enhanced Field Supply's harness connector P4 into the wire harness with connector S4.

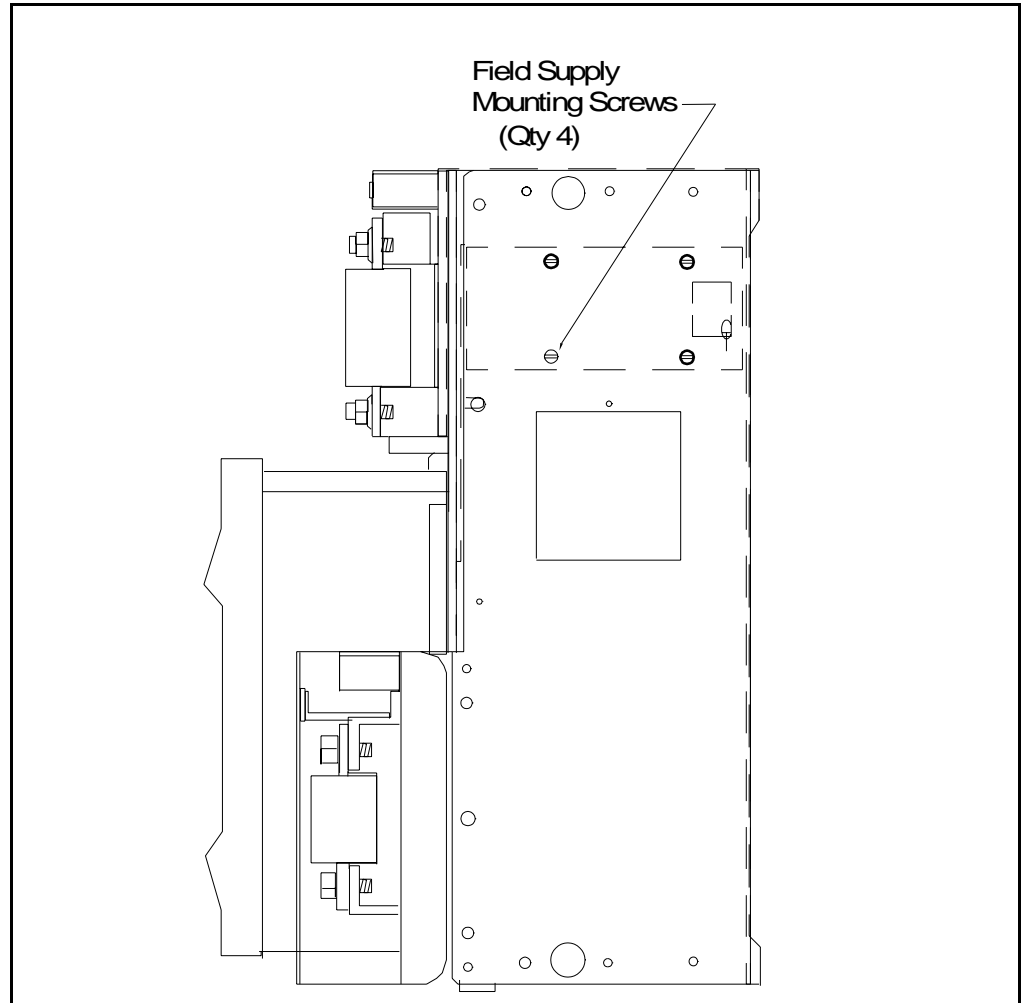

Figure 3.2 – Installing the Enhanced Field Supply Board (75 HP to 150 HP @ 460 VAC Drives)

3.6 Replacing the Drive Fuses

- Step 1. Locate the three fuses labeled 6FU, 7FU, and 8FU. See figure 3.3.
- Step 2. If the fuses are different from the three provided 25 A, 600 V fuses (P/N 64676–30M), replace them with the ones provided.
- Step 3. Locate the replacement fuse table on the back of the carrier. Attach one of the adhesive fuse rating labels (P/N 179540) over each of the places indicated in figure 3.4.

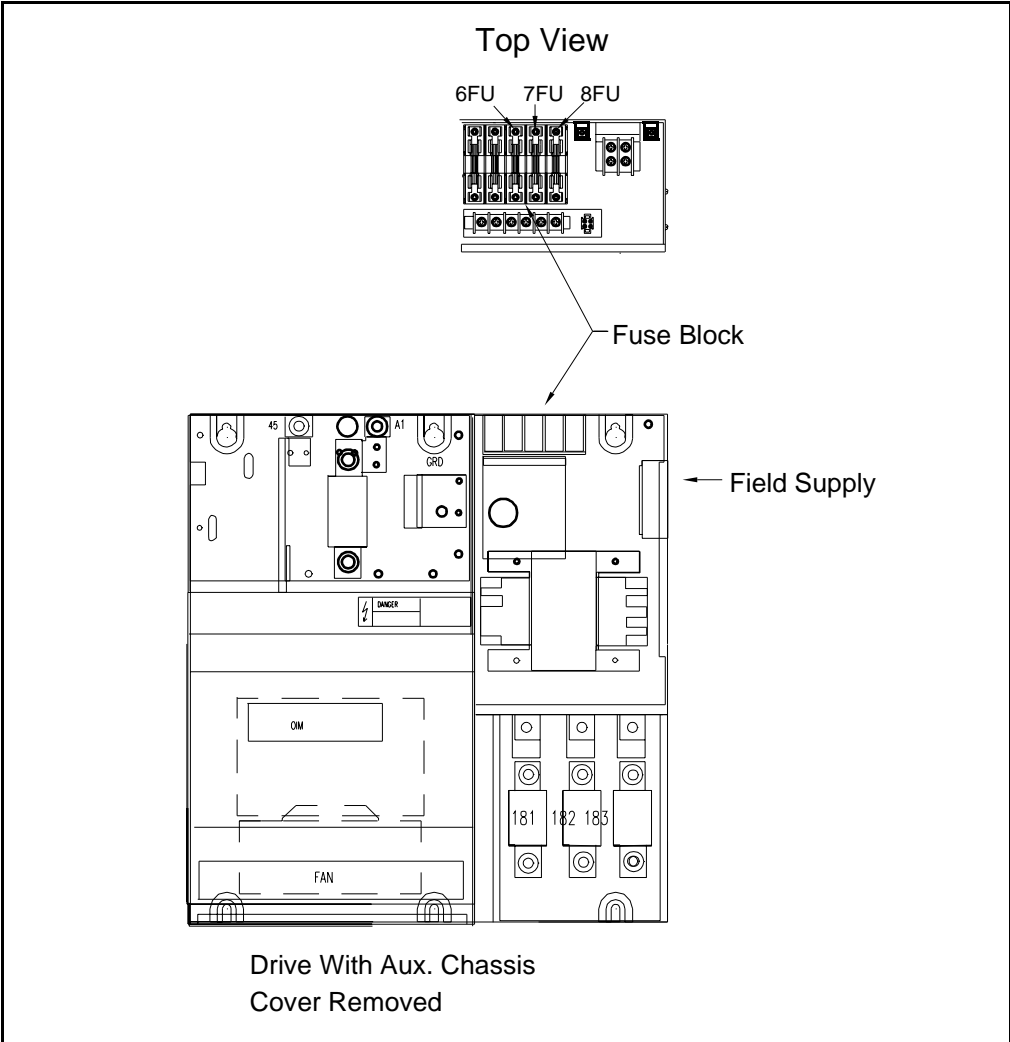

Figure 3.3 – Field Fuse Location (75 HP to 150 HP @ 460 VAC Drives)

REPLACE FUSES WITH: 802274-34A				
FOR S6				
HP @ 230VAC	1FU 2FU 3FU BRUSH type XL50F	4FU 5FU LITTELFUSE type KLDR	6FU 7FU 8FU CLASS CC non-time delay	
40	500V 300A	600V 4.5A	600V 15A	600V 25A
50				
60				
75	500V 350A		600V 25A	
HP @ 460VAC	1FU 2FU 3FU BRUSH type XL50F	4FU 5FU LITTELFUSE type KLDR	6FU 7FU 8FU CLASS CC non-time delay	
75	500V 300A	600V 2.25A	600V 15A	600V 25A
100				
125				
150	500V 350A		600V 25A	
FOR S6R				
HP @ 230VAC	11FU BRUSH type XL70F	1FU 2FU 3FU BRUSH type XL50F	4FU 5FU LITTELFUSE type KLDR	6FU 7FU 8FU CLASS CC non-time delay
40	700V 200A	500V 300A	600V 4.5A	600V 15A
50	700V 250A			
60	700V 300A			
75	700V 350A	500V 350A		600V 25A
HP @ 460VAC	11FU BRUSH type XL70F	1FU 2FU 3FU BRUSH type XL50F	4FU 5FU LITTELFUSE type KLDR	6FU 7FU 8FU CLASS CC non-time delay
75	700V 200A	500V 300A	600V 2.25A	600V 15A
100	700V 250A			
125	700V 300A			
150	700V 350A	500V 350A		600V 25A

Figure 3.4 – Attaching Replacement Drive Fuse Labels (75 HP to 150 HP @ 460 VAC Drives)

3.7 Reinstalling the Auxiliary Chassis Cover

These steps apply if your drive does not have an AC disconnect. If your drive has an AC disconnect, skip this section and go to section 3.8.

- Step 1. Insert the tabs on the left side of the auxiliary chassis cover into the slots on the right side of the drive's motor terminal panel.
- Step 2. Align the auxiliary chassis cover over the middle screw on the drive's right side panel and over the top and bottom mounting holes.
- Step 3. Insert the top and bottom screws into the mounting screw holes and then tighten all three mounting screws (top, bottom, and middle).
- Step 4. Tighten the two screws on the right side of the motor terminal panel to secure the auxiliary chassis cover's tabs in place.
- Step 5. Reconnect power to the drive.
- Step 6. Remove the lockout and tag.
- Step 7. Turn on power to the drive.

3.8 Reinstalling the AC Disconnect

If your drive has an AC disconnect that was removed, refer to instruction manual D2-3395 (CE-compliant drives) or D2-3315 (non-CE-compliant drives) for the procedure to reinstall it.

3.9 Modifying the Drive Configuration

Go to chapter 7 and follow the procedures described there to set the parameters for the Enhanced Field Supply kit.

Installing the Enhanced Field Supply Kit on 200 HP to 300 HP @ 460 VAC (100 HP to 150 HP @ 230 VAC) Drives



ATTENTION: Only qualified personnel familiar with the construction and operation of this equipment and the hazards involved should install, operate, and/or service this equipment. Read and understand this instruction manual in its entirety before proceeding. Failure to observe this precaution could result in severe bodily injury or loss of life.

ATTENTION: The drive is at line voltage when connected to incoming AC power. Disconnect, tag and lockout all incoming power to the drive before performing the following procedure. Failure to observe this precaution could result in severe bodily injury or loss of life.

Installing the Enhanced Field Supply kit on 200 HP to 300 HP @ 460 VAC (100 HP to 150 HP @ 230 VAC) drives requires completing the following steps.

- Removing the Field Current Regulator board
- Adjusting the Jumpers on the Enhanced Field Supply board and the Regulator board
- Installing the Enhanced Field Supply board
- Reinstalling the OIM and Its Cover
- Replacing the Drive Fuses
- Modifying the Drive Configuration

These steps are described in detail below.

When you have finished installing the kit, adjust the required drive parameters as described in chapter 6 before using the drive.

4.1 Removing the Field Current Regulator Board



ATTENTION: The drive contains printed circuit boards that are static sensitive. An anti-static wrist band should be worn by any person who touches the drive's components, connectors or leads. Erratic machine operation and damage to , or destruction of, equipment may result if this procedure is not followed. Failure to observe this precaution may result in bodily injury.

Step 1. Turn off, lockout, and tag power to the drive.

- Step 2. Locate the Field Current Regulator board. It is attached to the lower right side of the drive, behind the line fuse panel, and can be accessed through the bottom of the drive. See figure 4.1.
- Step 3. Remove the four field supply mounting screws from the outside of the drive's right side panel and remove the field supply.
- Step 4. Disconnect the drive's wire harness from the field supply board's 581, 582, 583, F2/35, and F1/37 connectors.
- Step 5. Disconnect the Field Current Regulator cable assembly (P/N 707973–12R, S, or T) FLD P6 and FLD P3 connectors from the Field Current Regulator board. Also unplug the opposite end of this cable. Do not remove the cable.

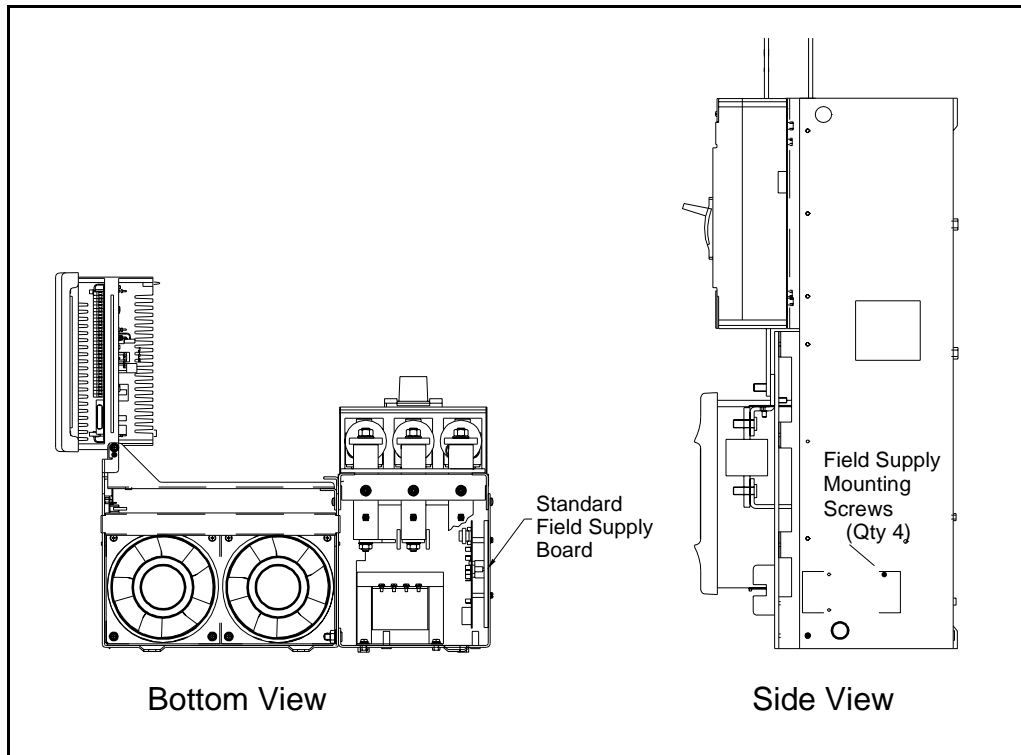

Figure 4.1 – Removing the Field Current Regulator Board (200 HP to 300 HP @ 460 VAC Drives)

4.2 Adjusting the Jumpers on the Enhanced Field Supply Board and the Regulator Board

- Step 1. Refer to chapter 6 to determine the correct field output range jumpering for your application. If it is necessary to change jumper settings, follow the remaining steps in this section.

Important: All Enhanced Field Supply boards are shipped with the wire jumper connecting pins "B" and "C". The actual field output voltage, once the range is jumper selected, is adjusted through the drive's OIM (operator interface module).

- Step 2. If necessary, move the Enhanced Field Supply board's wire jumper to select an output voltage range. (pin "A" connected to pin "C" or pin "B" connected to pin "C".) See figure 2.2.
- Step 3. Loosen the two screws holding the OIM cover in place and remove it.

- Step 4. Remove the four (4) screws securing the OIM to the Regulator board carrier and move the OIM to gain access to the drive's Regulator board. It is not necessary to remove the OIM completely, though it can be by disconnecting the ribbon and ground connectors from the underside of the OIM. If you disconnect the ground, note the terminal so you can correctly reconnect it later.
- Step 5. Locate Regulator board jumper J21 (FIELD SUPPLY JUMPER). See figure 2.2.
- Step 6. If necessary, move Regulator board jumper J21 so that it matches the jumper setting of the Enhanced Field Supply board (A–C or B–C).

4.3 Installing the Enhanced Field Supply Board

- Step 1. Connect the drive's wire harness to the Enhanced Field Supply board's 581, 582, 583, F2/35 and F1/37 spade connectors. See figure 1.1 for the location of the connectors.
- Step 2. Connector S4 on the harness might have a protective connector on it. If so, remove it. Plug the Enhanced Field Supply's harness connector P4 into the harness connector S4.
- Step 3. Remove the four mounting screw from the back of the Enhanced Field Supply board.
- Step 4. Working from the inside of the drive, align the Enhanced Field Supply board's mounting holes with the mounting holes on the drive's right side panel. See figure 4.1. Orient this board so that the end with the transformer points to the front of the drive.
- Step 5. Working from the outside of the drive, insert one of the mounting screws (removed in step 3) through one of the mounting holes on the drive's right side panel and into the corresponding mounting hole on the Enhanced Field Supply board. Tighten the screw to just enough hold the board in place.
- Step 6. Repeat step 5 for the remaining three mounting screws. Then tighten all four screws.

4.4 Reinstalling the OIM and Its Cover

- Step 1. If it was previously removed, reinstall the OIM on the Regulator board carrier.
- Step 2. Reinstall the OIM cover.

4.5 Replacing the Drive Fuses

- Step 1. Locate the fuse block on the drive's line fuse panel and its three fuses labeled 6FU, 7FU, and 8FU.
- Step 2. If the installed fuses are different from the ones provided with this kit, replace them with the provided 25 A, 600 V fuses (P/N 64676–30M).
- Step 3. Reconnect power to the drive.
- Step 4. Remove the lockout and tag.
- Step 5. Turn on power to the drive.

4.6 Modifying the Drive Configuration

Go to chapter 7 and follow the procedures described there to set the parameters for the Enhanced Field Supply kit.

Installing the Enhanced Field Supply Kit on 400 HP to 600 HP @ 460 VAC Drives



ATTENTION: Only qualified personnel familiar with the construction and operation of this equipment and the hazards involved should install, operate, and/or service this equipment. Read and understand this instruction manual in its entirety before proceeding. Failure to observe this precaution could result in severe bodily injury or loss of life.

ATTENTION: The drive is at line voltage when connected to incoming AC power. Disconnect, tag and lockout all incoming power to the drive before performing the following procedure. Failure to observe this precaution could result in severe bodily injury or loss of life.

Installing the Enhanced Field Supply kit on 400 HP to 600 HP @ 460 VAC drives requires completing the following steps.

- Removing the Drive Cover and Opening the Carrier
- Removing the Field Current Regulator board
- Adjusting the Jumpers on the Enhanced Field Supply board and the Regulator board
- Installing the Enhanced Field Supply board
- Resecuring the Hinged OIM Mounting Plate
- Replacing the Drive Fuses
- Reinstalling the Plastic Cover and Reclosing the Steel Door
- Modifying the Drive Configuration

These steps are described in detail below.

When you have finished installing the kit, adjust the required drive parameters as described in chapter 7 before using the drive.

5.1 Removing the Drive Cover and Opening the Carrier



ATTENTION: The drive contains printed circuit boards that are static sensitive. An anti-static wrist band should be worn by any person who touches the drive's components, connectors or leads. Erratic machine operation and damage to, or destruction of, equipment may result if this procedure is not followed. Failure to observe this precaution may result in bodily injury.

- Step 1. Turn off, lockout, and tag power to the drive.
- Step 2. Remove the clear plastic cover from the right side of the drive. Loosen, but don't remove, the two screws at its base and then lift up and out.
- Step 3. Remove the two bolts in the right corner of the steel door that is directly above the Operator Interface Module (OIM). Open this door. It swings to the left and exposes the extender panel on which the field supply board is mounted. See RT. EXTENDER PANEL in figure 5.1. The inside of this door has snubber circuit components mounted on it.
- Step 4. Remove the two screws in the right corners of the hinged OIM mounting plate. You can swing it open to provide more working room and a place that disconnected cables can be tie-wrapped later.
- Step 5. Loosen the two thumb screws on the OIM cover and remove the cover from the carrier.

5.2 Removing the Field Current Regulator Board

- Step 1. Locate the Field Current Regulator board. It is attached to the left side of the extender panel. See figure 5.1.
- Step 2. Remove the four field supply mounting screws from the right side of the extender panel and remove the Field Current Regulator board.
- Step 3. Disconnect the drive's wire harness from the Field Current Regulator board's 581, 582, 583, F2/35, and F1/37 connectors. See figure 5.2 for their locations.
- Step 4. Disconnect the Field Current Regulator cable assembly (P/N 707973-12R, S, or T) FLD P6 and FLD P3 connectors from the Field Current Regulator board. See figure 5.2 for their locations. Also disconnect the opposite end of this cable from J25. Do not remove the cable.

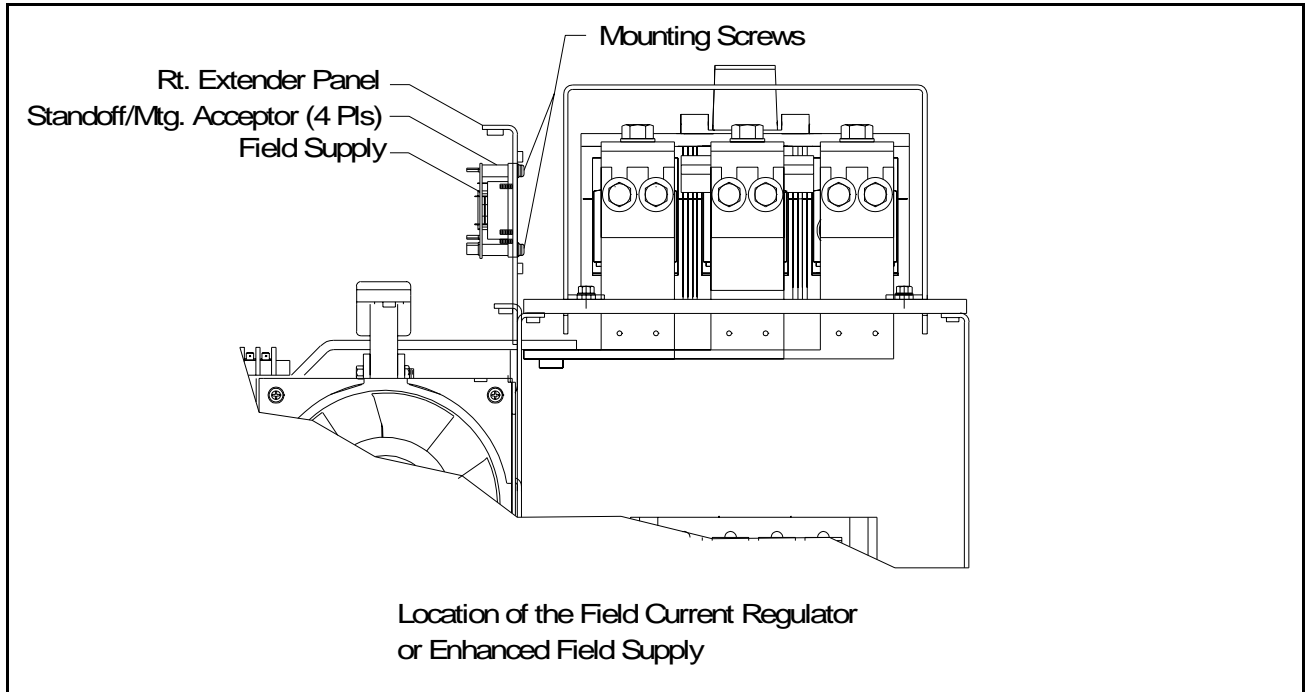

Figure 5.1 – Removing the Field Current Regulator Board (400 HP to 600 HP @ 460 VAC Drives)

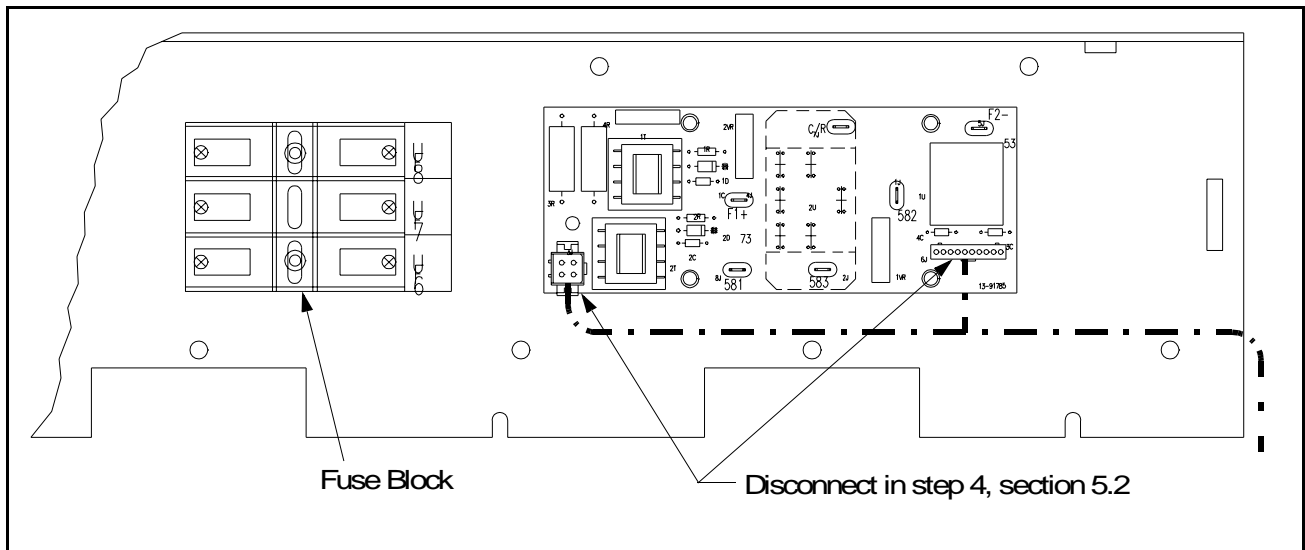

Figure 5.2 – Location of Field Current Regulator Connectors

5.3 Adjusting the Jumpers on the Enhanced Field Supply Board and the Regulator Board

Step 1. Refer to chapter 6 to determine the correct field output range jumpering for your application.

Important: All Enhanced Field Supply boards are shipped with the wire jumper connecting pins "B" and "C". The actual field output voltage, once the range is jumper selected, is adjusted through the drive's OIM.

- Step 2. If necessary, move the Enhanced Field Supply board's wire jumper to select an output voltage range. (pin "A" connected to pin "C" or pin "B" connected to pin "C".) See figure 2.2.
- Step 3. Remove the four screws that secure the OIM (control and display panel) to the carrier. Note the horizontal ribbon cable connecting the OIM board to the Regulator board at the lower left of the Regulator board. Carefully disconnect this ribbon cable from the Regulator board. It is not necessary to remove the OIM completely, although it can be by disconnecting the ground connector from the underside of the OIM.
- Step 4. After the OIM is moved out of the way, locate Regulator board jumper J21 (FIELD SUPPLY JUMPER). It is close to the left edge of the Regulator board, under the vertical ribbon connector. This jumper connects pins A to C or B to C. See figure 2.3.
- Step 5. If necessary, move Regulator board jumper J21 so that it matches the jumper settings of the Enhanced Field Supply board (A-to-C or B-to-C); that is, make this jumper connection consistent with the jumper selection in steps 1 and 2 above.

5.4 Reinstalling the OIM and Cover

- Step 1. Reconnect the ground connection to the back of the OIM if you previously removed it.
- Step 2. Reposition the OIM on the carrier. Then replace and tighten the four mounting screws.
- Step 3. Reconnect the horizontal ribbon connector between the OIM and the Regulator board.
- Step 4. Reinstall the cover on the OIM and tighten its thumb screws.

5.5 Installing the Enhanced Field Supply Board

- Step 1. Remove the four mounting screws from the back of the Enhanced Field Supply board. See figures 5.1 and 5.3.
- Step 2. Align the Enhanced Field Supply board's mounting holes with the mounting holes on the drive's extender panel. See figures 5.1 and 5.3.
- Step 3. Working on the right side of the extender panel, insert a mounting screw (removed in step 1) through one of the mounting holes in the extender panel. Turn it to catch the threads in the Enhanced Field Supply board's mating mounting hole.
- Step 4. Repeat step 3 for the remaining three mounting screws and then tighten each screw.
- Step 5. Connect the drive's wire harness to the Enhanced Field Supply board's 581, 582, 583, F2/35 and F1/37 spade connectors. See figure 2.2 for the location of these connectors.
- Step 6. Plug the Enhanced Field Supply's harness connector P4, shown in figure 2.2, into the harness with connector S5. The S5 connector runs off a wire harness directly below the Enhanced Field Supply Board. For safety, this connector may have a mating "dummy" connector plugged into it. Remove the dummy connector.

Step 7. Tie-wrap or otherwise secure the cables that were disconnected in step 4, section 5.2 above. Secure or tie-wrap these cables to other wrapped cables or on cables under the hinged OIM mounting plate which swings out of the way.

Important: Do not secure these cables to the gray power cables.

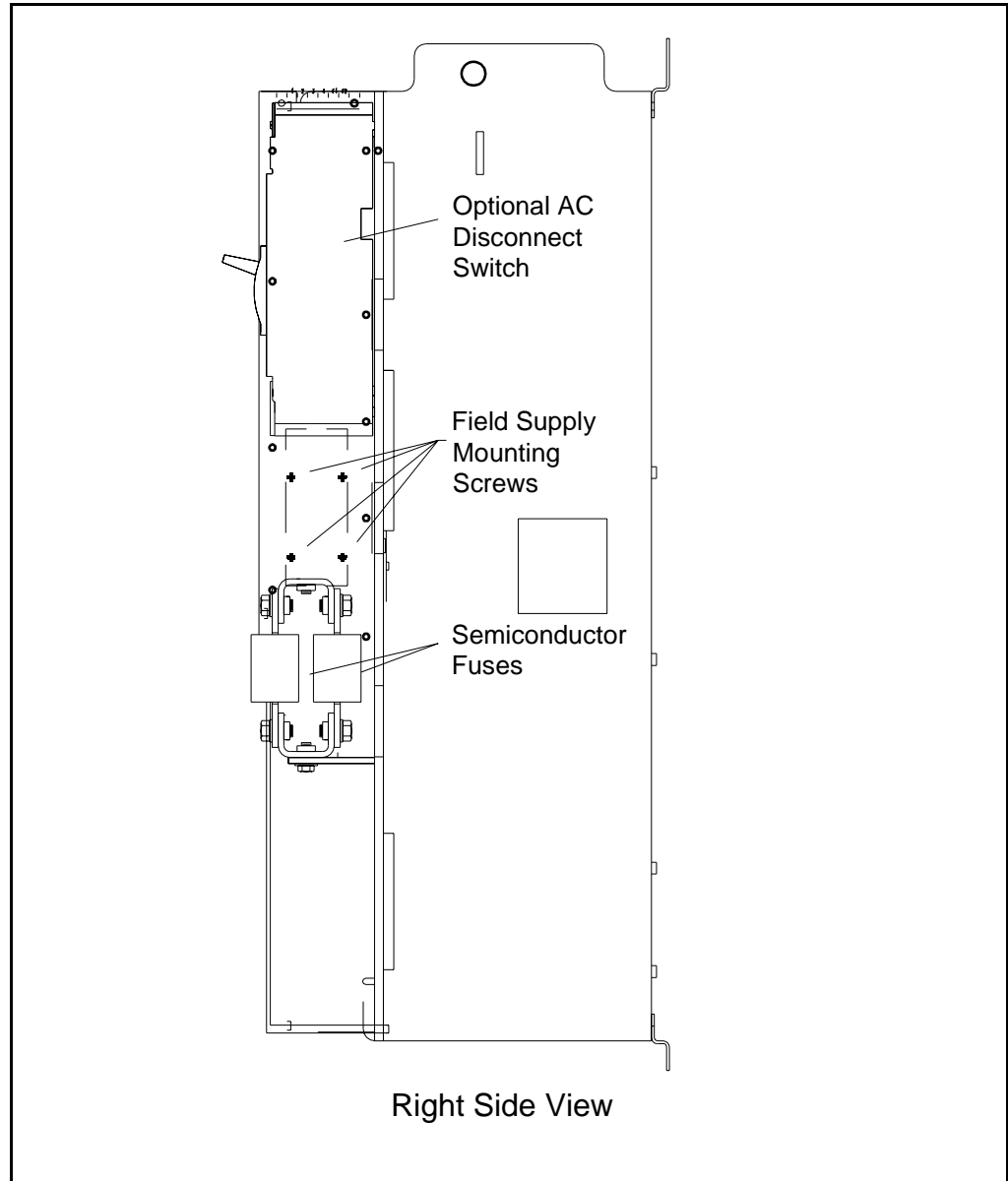

Figure 5.3 – Mounting the Enhanced Field Supply

5.6 Resecuring the Hinged OIM Mounting Plate

If previously swung open (to the left), swing the OIM mounting plate back into position. Replace and tighten its mounting screws.

5.7 Replacing the Drive Fuses

- Step 1. Locate the fuse block, labeled 6FU, 7FU, and 8FU, on the drive's line fuse panel. See figure 2.2.
- Step 2. If the installed fuses are different from the ones provided with this kit, replace them with the ones provided (25 A, 600 V (P/N 64676–30M)).

5.8 Reinstalling the Plastic Drive Cover and Reclosing the Steel Door

- Step 1. Reinstall the plastic cover over the drive's line fuse panel. Hardware installation is complete.
- Step 2. Swing the steel door closed. Then replace and tighten the two bolts in the right-hand corners.
- Step 3. Reconnect power to the drive.
- Step 4. Remove the lockout and tag.
- Step 5. Turn on power to the drive.

5.9 Modifying the Drive Configuration

Go to chapter 7 and follow the procedures described there to set the parameters for the Enhanced Field Supply kit.

Setting the Field Voltage Trim Jumpers

Given a supplied line voltage, field voltage trimming is used to match the drive's field output to the rated field voltage of different DC motors.

In general, a field voltage below the motor's rated field voltage could operate the motor above rated (base) speed with reduced torque. A field voltage above the motor's rated field voltage could result in armature overvoltage and excessive heating in the motor's field windings.

Determining the Correct Jumper Setting for Field Voltage Trim

You must set two jumpers to configure field voltage trim. Complete the following steps to determine the correct jumper setting for the Enhanced Field Supply board and the Regulator board:

Begin with your AC line input voltage and your motor's rated DC field voltage.

Step 1. Calculate the line multiplier according to the following formula:

$$\text{LINE MULTIPLIER} = \frac{\text{Motor Rated DC Field Voltage}}{\text{AC Line Input Voltage}}$$

Step 2. Use the resulting line multiplier to set the jumpers as indicated in the following table:

Table 6.1 – Setting the Enhanced Field Supply Board and the Regulator Board Jumpers

If the line multiplier falls between:	Set J21 on the Regulator Board to:	Set the jumper on the Enhanced Field Supply Board to:
0.45 to 0.9	B–C	B–C
0.91 to 1.12	A–C	A–C

For example:

AC Line Input Voltage = 230
 Motor's Rated DC Field Voltage = 150

$$\frac{150}{230} = 0.6528$$

Use jumper setting B–C because the multiplier falls between 0.45 and 0.9.

Modifying the Drive Configuration

Proper operation of the Enhanced Field Supply requires the verification and adjustment of three drive parameters:

- Parameter 306 (NOMINAL AC LINE FREQUENCY)
- Parameter 500 (ENHANCED FLD VOLT ADJ)
- Parameter 501 (FIELD ECONOMY DELAY)

These parameters are accessed through the CURRENT MINOR LOOP and FIELD menus.

7.1 Parameter 306 (NOMINAL AC LINE FREQUENCY)

This parameter value must match the AC input line's frequency. Access parameter 306 using the OIM's CURRENT MINOR LOOP menu. Verify and adjust, if necessary, the drive's parameter value to match the AC line frequency.

7.2 Parameter 500 (ENHANCED FLD VOLT ADJ)



ATTENTION: Improper setting of the field voltage can cause the motor to run at dangerously high speeds. The field voltage adjust parameter must not be changed without an understanding of the parameter's function, application, mechanics of the motor (maximum safe speed), and the driven machines. Failure to observe this precaution could result in severe bodily injury.

Given a supplied line voltage, parameter 500 (ENHANCED FLD VOLT ADJ) is used to match the drive's field output voltage to the rated field voltage of a DC motor. The drive's output field voltage is equal to the AC input line voltage times a line multiplier. As shown in tables 7.1 and 7.2, each value of parameter 500 is associated with a given line multiplier for a specified jumper selection. You must determine the field voltage trim line multiplier as described in chapter 6 before proceeding.

Important: If the drive is operating in the field economy mode, this adjustment will have no effect on the output field voltage.

- Step 1. Once you have calculated the line multiplier, find the multiplier (or one very close in value) in tables 7.1 or 7.2.
- Step 2. Adjust parameter 500 to the value associated with the line multiplier chosen from the table. The parameter value is equal to:

$$\text{Parameter 500 value} = \text{1st column value} + \text{row header value}$$

Important: This value is intended to give you a starting pointing for adjusting the drive's field output voltage. Use an external voltmeter to measure actual field voltage in order to make an accurate adjustment of the field voltage.

Step 3. Check the drive's field output voltage. If necessary, readjust parameter 500 to obtain the motor's rated field voltage.

7.3 Examples for Setting Parameters 306 and 500

A 230 VAC, 60 Hz line is connected to a FlexPak 3000 drive. The drive's output, in turn, is applied to a 5 HP DC motor having a nameplate field voltage of 150 volts.

Step 1. Verify that parameter 306 (NOMINAL AC LINE FREQUENCY) has the correct value, 60 Hz in this example.

Step 2. Calculate the multiplier that determines Enhanced Field Supply board and Regulator board jumpering. See chapter 6 for more information. Determine the value for parameter (ENHANCED FLD VOLT ADJ). The equation for this example is:

$$\frac{\text{FIELD VOLTAGE}}{\text{AC INPUT VOLTAGE}} = \text{MULTIPLIER} = \frac{150}{230} = 0.6522$$

Step 3. Refer to table 6.1 for the calculated multiplier. In this example, the calculated multiplier of 0.6522 falls between 0.45 and 0.9, so the correct jumpering for the Enhanced Field Supply board and Regulator board jumper J21 is B-C.

Step 4. Determine the value for parameter 500.

a. Refer to table 7.1, which supplies the multipliers for the B-C jumper setting.

b. Find the row and column containing the multiplier closest to 0.6522. The closest multiplier is 0.6517. It is located in row 080, column 4.

c. To find the value for parameter 500, add the column number to the row number. In this case it is:

$$080 + 4 = 84$$

d. Access parameter 500 from the OIM's FIELD menu and set the value to 84.

Table 7.1 – Parameter 500 Values When Jumpers are Set to B–C

	0	1	2	3	4	5	6	7	8	9
000	0.4502	0.4502	0.4503	0.4505	0.4507	0.4510	0.4514	0.4518	0.4523	0.4529
010	0.4536	0.4543	0.4551	0.4559	0.4568	0.4578	0.4589	0.4600	0.4612	0.4624
020	0.4637	0.4651	0.4665	0.4681	0.4696	0.4712	0.4729	0.4747	0.4765	0.4784
030	0.4803	0.4823	0.4844	0.4865	0.4886	0.4909	0.4931	0.4955	0.4979	0.5003
040	0.5028	0.5054	0.5080	0.5106	0.5133	0.5161	0.51 89	0.5217	0.5246	0.5276
050	0.5306	0.5336	0.5367	0.5398	0.5429	0.5461	0.5494	0.5527	0.5560	0.5593
060	0.5627	0.5661	0.5696	0.5731	0.5766	0.5801	0.5837	0.5873	0.5909	0.5946
070	0.5983	0.6020	0.6057	0.6094	0.6132	0.61 70	0.6208	0.6246	0.6284	0.6323
080	0.6362	0.6400	0.6439	0.6478	0.6517	0.6556	0.6595	0.6635	0.6674	0.6713
090	0.6752	0.6792	0.6831	0.6870	0.6909	0.6940	0.6988	0.7027	0.7066	0.7104
100	0.7143	0.7182	0.7220	0.7259	0.7297	0.7335	0.7373	0.7410	0.7448	0.7485
110	0.7522	0.7559	0.7596	0.7632	0.7668	0.7704	0.7739	0.7774	0.7809	0.7844
120	0.7878	0.7912	0.7945	0.7978	0.8011	0.8043	0.8075	0.8107	0.8138	0.8169
130	0.8199	0.8229	0.8258	0.8287	0.8316	0.8344	0.8371	0.8398	0.8425	0.8451
140	0.8477	0.8502	0.8526	0.8550	0.8573	0.8596	0.8618	0.8640	0.8661	0.8682
150	0.8702	0.8721	0.8740	0.8758	0.8775	0.8792	0.8809	0.8824	0.8838	0.8854
160	0.8867	0.8881	0.8893	0.8905	0.8916	0.8926	0.8936	0.8945	0.8954	0.8962
170	0.8969	0.8975	0.8981	0.8986	0.8991	0.8995	0.8998	0.9000	0.9002	0.9003
180	0.9003									

Table 7.2 – Parameter 500 Values When Jumpers are Set to A–C

	0	1	2	3	4	5	6	7	8	9
000	0.9003	0.9004	0.9005	0.9006	0.9009	0.9012	0.9015	0.9020	0.9025	0.9031
010	0.9037	0.9045	0.9052	0.9061	0.9070	0.9080	0.9090	0.9102	0.9113	0.9126
020	0.91 39	0.91 53	0.91 67	0.9182	0.91 98	0.9214	0.9231	0.9248	0.9267	0.9285
030	0.9305	0.9325	0.9345	0.9366	0.9388	0.9410	0.9433	0.9456	0.9480	0.9505
040	0.9530	0.9555	0.9581	0.9608	0.9635	0.9662	0.9690	0.9719	0.9748	0.9777
050	0.9807	0.9837	0.9868	0.9899	0.9931	0.9963	0.9995	1.0028	1.0061	1.0095
060	1.0129	1.0162	1.0196	1.0229	1.0262	1.0294	1.0326	1.0358	1.0389	1.0420
070	1.0450	1.0480	1.0509	1.0538	1.0567	1.0595	1.0622	1.0649	1.0676	1.0702
080	1.0727	1.0752	1.0777	1.0801	1.0824	1.0847	1.869	1.0891	1.0912	1.0932
090	1.0952	1.0972	1.0990	1.1009	1.1026	1.1043	1.1059	1.1075	1.1090	1.1104
100	1.1118	1.1131	1.1144	1.1156	1.1167	1.1177	1.1187	1.1196	1.1205	1.1213
110	1.1220	1.1226	1.1232	1.1237	1.1242	1.1245	1.1248	1.1251	1.1253	1.1254
120	1.1252									

7.4 Parameter 501 (FIELD ECONOMY DELAY)

Parameter 501 is used to adjust the field economy time delay for those motors that may not be able to withstand the power dissipation under full field voltage with the motor at rest. After a user-specified time delay (0 to 27 minutes), FlexPak 3000 drives provide an automatic fixed reduction of field voltage, known as field economy, during motor rest periods. When the drive restarts, the FlexPak returns to its user-adjusted full field output voltage level.

Access parameter 501 from the OIM's FIELD menu and adjust the value to an appropriate time delay for your motor and application.

Documentation Improvement Form

Use this form to give us your comments concerning this publication or to report an error that you have found. For convenience, you may attach copies of the pages with your comments. After you have completed this form, please return it to:

Reliance Electric
Technical Documentation
24800 Tungsten Road
Cleveland, Ohio 44117

Fax: 216.266.7785

Publication Name: FlexPak 3000 Enhanced Field Supply Kit Installation Instructions	
Publication Number: D2-3413-1	Publication Date: November 2000

Comments:

Your Name:	Date:
Company Name:	Phone: ()
Address:	

Thank you for your comments.

Technical Writing Internal Use	
Date:	DIF Number:
Follow-Up Action:	

Reach us now at www.rockwellautomation.com

Wherever you need us, Rockwell Automation brings together leading brands in industrial automation including Allen-Bradley controls, Reliance Electric power transmission products, Dodge mechanical power transmission components, and Rockwell Software. Rockwell Automation's unique, flexible approach to helping customers achieve a competitive advantage is supported by thousands of authorized partners, distributors and system integrators around the world.

Americas Headquarters, 1201 South Second Street, Milwaukee, WI 53204, USA, Tel: (1) 414 382 2000, Fax: (1) 414 382 4444
European Headquarters SA/NV, Boulevard du Souverain 36, 1170 Brussels, Belgium, Tel: (32) 2 663 06 00, Fax: (32) 2 663 06 40
Asia Pacific Headquarters, 27/F Citicorp Centre, 18 Whitfield Road, Causeway Bay, Hong Kong, Tel: (852) 2887 4788, Fax: (852) 2508 1846
Reliance Electric Standard Drives Business, 24800 Tungsten Road, Cleveland, OH 44117, USA, Tel: (1) 888 374 8370, Fax: (216) 266 7095

