

# Dynamic Braking Kit for FlexPak Plus and MinPak Plus DC Drives

Model Numbers 14C214, 14C215, 14C216

Instruction Manual D2-3378



**ATTENTION:** Only qualified electrical personnel familiar with the construction and operation of this equipment and the hazards involved should install, adjust, operate, and/or service this equipment. Read and understand this manual and other applicable manuals in their entirety before proceeding. Failure to observe this precaution could result in severe bodily injury or loss of life.

## Product Description

Installation of the Dynamic Braking kit enables a single-phase FlexPak™ Plus or MinPak™ Plus DC drive to provide rapid, smooth stopping of the motor. If the Dynamic Braking kit is not used, the drive causes the motor to coast to rest when the contactor opens.

The Dynamic Braking kit includes a resistor that is automatically switched across the motor's armature when the drive is stopped. The rotating mechanical energy of the motor is converted into electrical energy that is rapidly dissipated as heat. The resistor is sized for infrequent stops, so time must be allowed between stops for the heat to dissipate.

**Important:** The dynamic brake is not a mechanical holding brake. It will not hold the motor shaft in place. It will not prevent the motor from turning once motion has stopped.

The Dynamic Braking kit must be rated for the drive's horsepower and voltage rating, as shown in table 1. Refer to your drive's nameplate for the horsepower and voltage rating. The Dynamic Braking kit contents are also listed in table 1.

Table 1 – Contents of the Dynamic Braking Kit

Description	Quantity	Kit Model Number and Rating	Reliance Part Number
Dynamic Braking Resistor	1	14C214 1/4 to 1/2 HP @ 115 VAC 2 to 3 HP @ 230 VAC	63481-150QHC
	1	14C215 3/4 HP @ 115 VAC	63481-150QCC
	1	14C216 1/2 to 1-1/2 HP and 5 HP @ 230 VAC	63481-150QNC
Mounting Screw, 4-40 x 3/8	2	All	601741-74C
Instruction Manual	1	All	D2-3378

## Installing the Dynamic Braking Kit in a FlexPak Plus DC Drive



**ATTENTION:** Do not install modification kits with power applied to the drive. Disconnect, lock out, and tag all sources of incoming AC power to the drive before attempting such installation. Verify that no voltage is present at the drive's AC input terminals, L1 and L2. Failure to observe this precaution could result in severe bodily injury or loss of life.

**ATTENTION:** The user is responsible for conforming with all applicable local, national, and international codes. Failure to observe this precaution could result in damage to, or destruction of, the equipment.

**Important:** Dynamic Braking kit installation procedures are different for FlexPak Plus drives and MinPak Plus DC drives. This section describes installation in a FlexPak Plus drive. See the next section for installation in a MinPak Plus drive.

Refer to your FlexPak Plus DC drive instruction manual for help locating and identifying drive components.

- Step 1. Disconnect, lock out, and tag input power to the drive.
- Step 2. Remove the drive cover.
- Step 3. Verify that no voltage is present at the drive's AC input terminals, L1 and L2.
- Step 4. Mount the dynamic braking resistor in the upper right corner on the back of the FlexPak Plus auxiliary panel. Use the two mounting screws provided.
- Step 5. **For all regenerative FlexPak Plus DC drives, and for non-regenerative FlexPak Plus DC drives without a Reversing Contactor:** Connect the dynamic braking resistor between the normally closed (NC) contacts of the drive's M-contactor (terminals 7 and 8). This places the resistor across the motor's armature (A1 and A2) when the M-contactor is de-energized. Refer to figures 1 and 2.

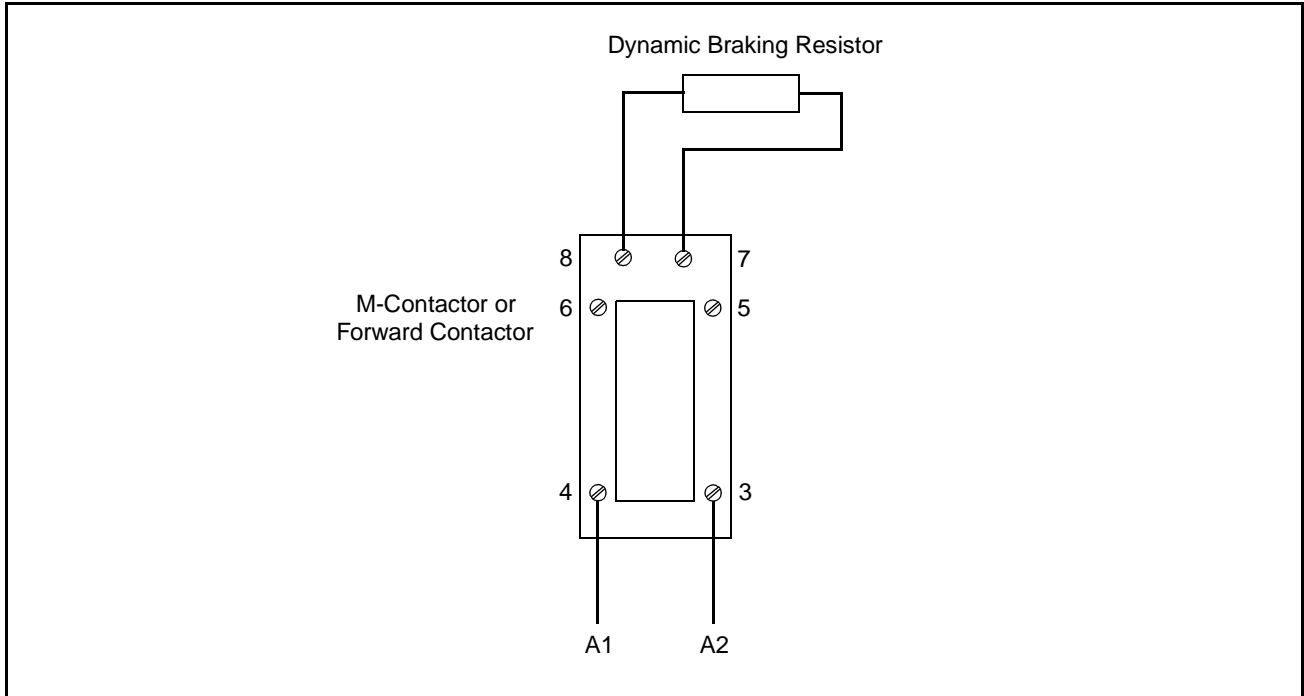

Figure 1 – Dynamic Braking Resistor Connections for Regenerative FlexPak Plus Drives and Non-Regenerative FlexPak Plus Drives Without a Reversing Contactor

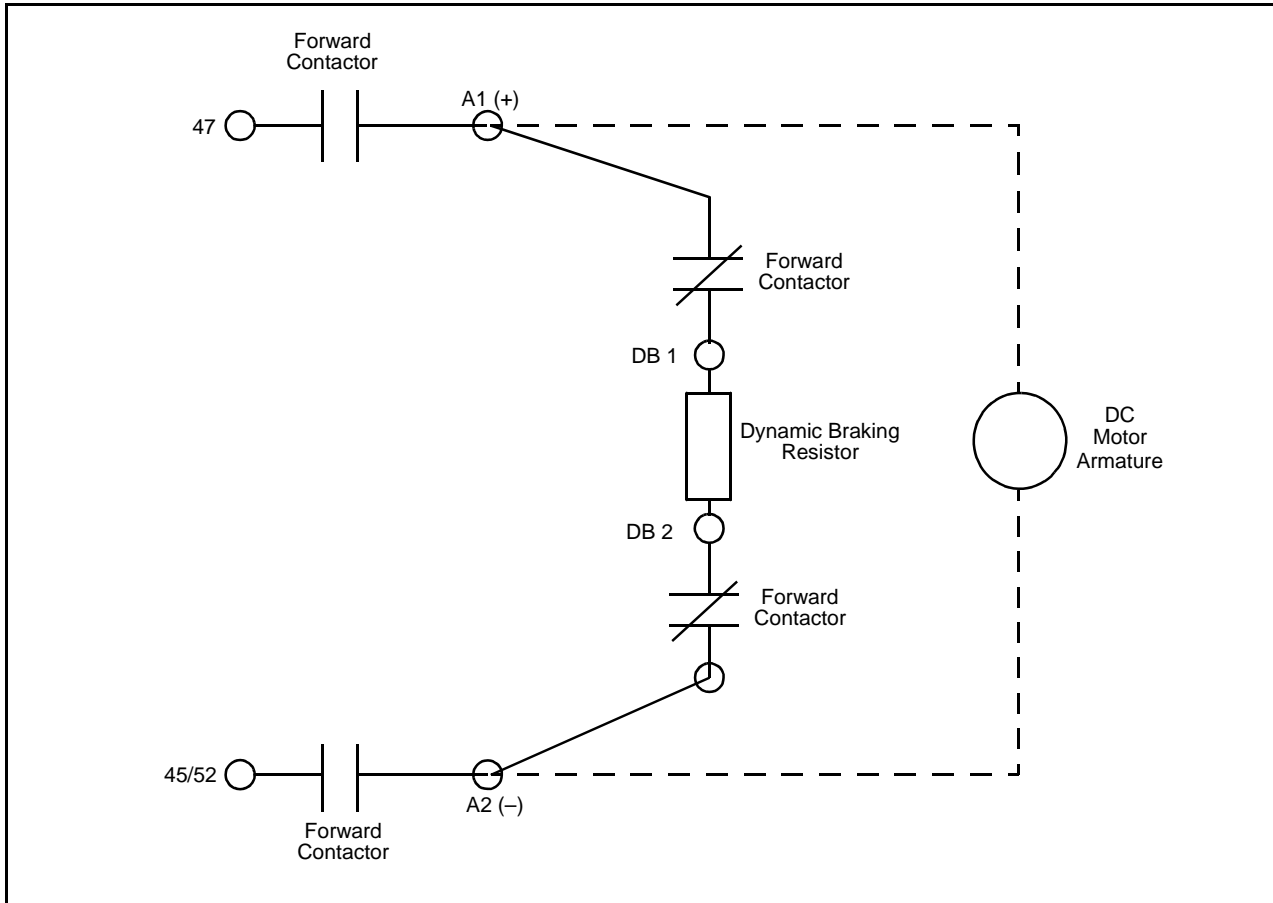

Figure 2 – Dynamic Braking Resistor Schematic for Regenerative Drives and Non-Regenerative Drives Without a Reversing Contactor

Step 6. **For non-regenerative FlexPak Plus DC drives with a Reversing Contactor:** Connect the dynamic braking resistor between the corresponding normally closed (NC) contacts on the forward contactor and the reversing contactor. For example, connect the resistor between terminal 8 on the forward contactor and terminal 8 on the reverse contactor. This places the resistor across the motor's armature (A1 and A2) when both contactors are de-energized. Refer to figures 3 and 4.

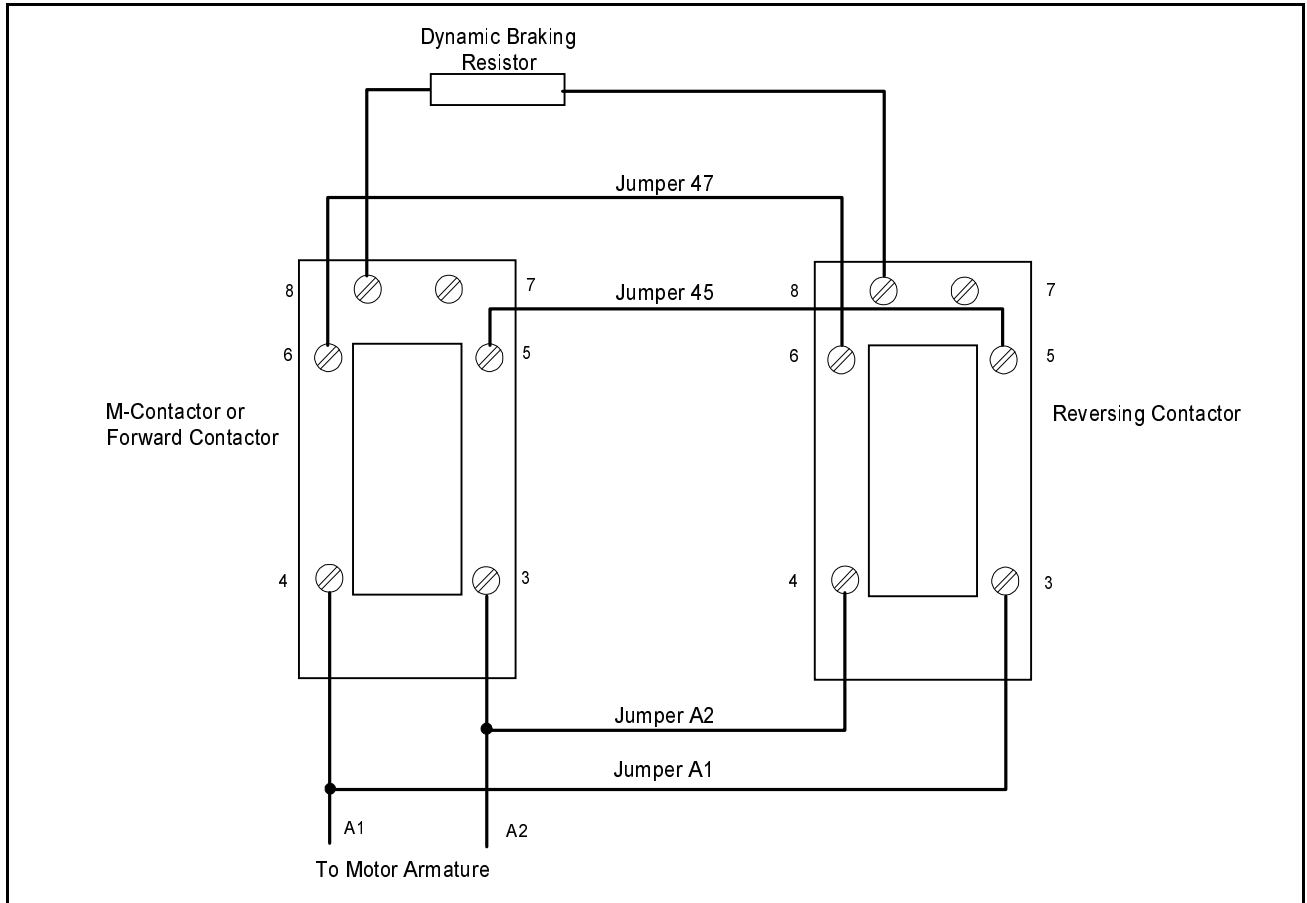

Figure 3 – Dynamic Braking Resistor Connections for Non-Regenerative FlexPak Plus Drives With a Reversing Contactor

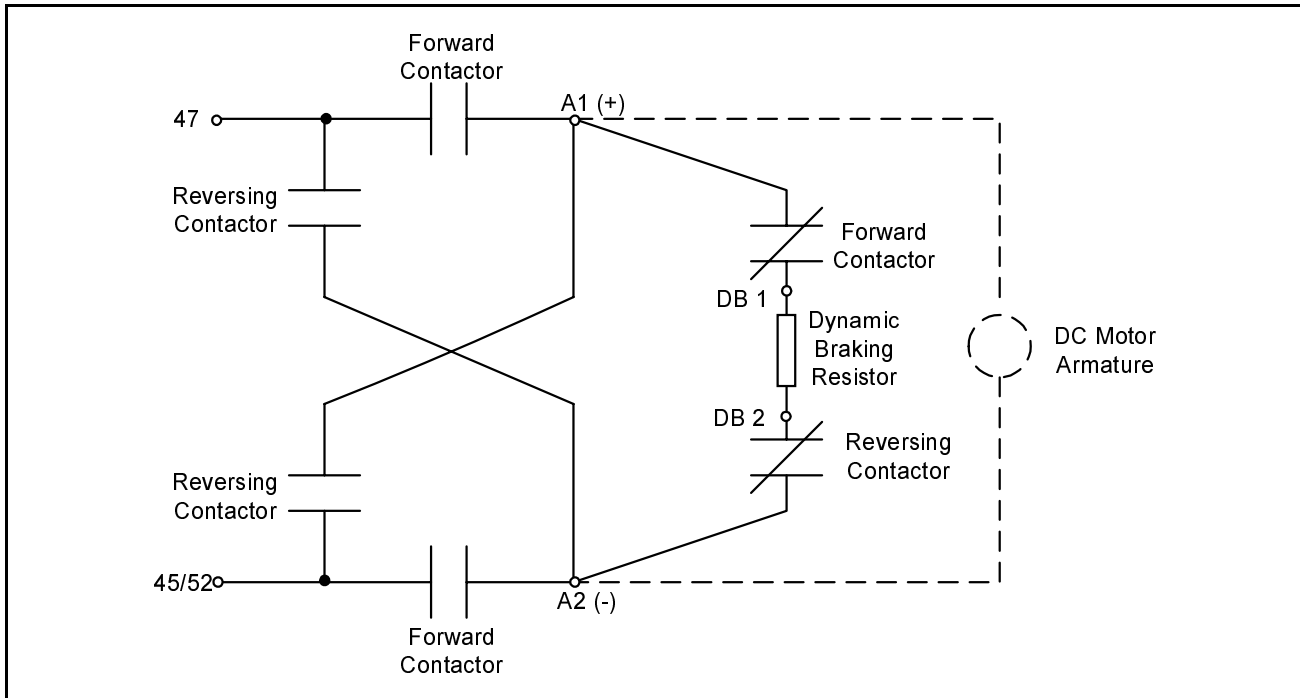

Figure 4 – Dynamic Braking Resistor Schematic for Non-Regenerative Drives with a Reversing Contactor



**ATTENTION:** If a reversing contactor is installed, ensure jumper J9 is removed from the Regulator board (near the top of board). Failure to observe this precaution could result in damage to, or destruction of, the equipment.

- Step 7. If a reversing contactor is installed, make sure jumper J9 is removed from the Regulator board (near the top of board). See the FlexPak Plus DC drive instruction manual for jumper location.
- Step 8. Verify the wiring of the Dynamic Braking resistor and that all connectors are securely fastened.
- Step 9. Reattach the cover to the drive.
- Step 10. Apply power and test the braking capability of the drive.

This completes installation of the Dynamic Braking kit for FlexPak Plus DC drives.

## Installing the Dynamic Braking Kit in a MinPak Plus DC Drive



**ATTENTION:** Do not install modification kits with power applied to the drive. Disconnect, lock out, and tag all sources of incoming AC power to the drive before attempting such installation. Verify that no voltage is present at the drive's AC input terminals, L1/181 and L2/182. Failure to observe this precaution could result in severe bodily injury or loss of life.

**ATTENTION:** The user is responsible for conforming with all applicable local, national, and international codes. Failure to observe this precaution could result in damage to, or destruction of, the equipment.

**Important:** Dynamic Braking kit installation is different for FlexPak Plus and MinPak Plus DC drives. This section describes how to install the Dynamic Braking kit in a MinPak Plus DC drive. Refer to the previous section for installation in a FlexPak Plus DC drive.

Refer to your MinPak Plus DC drive instruction manual for help locating and identifying drive components. Unless otherwise noted, the following steps must be performed on all MinPak Plus drives.

- Step 1. Disconnect, lock out, and tag input power to the drive.
- Step 2. Remove the drive cover.
- Step 3. Verify that no voltage is present at the drive's AC input terminals, L1/181 and L2/182.
- Step 4. Remove the two screws from the terminal block and circuit breaker mounting bracket. Position this bracket up and out of the way as far as possible.
- Step 5. **Regenerative MinPak Plus only:** Loosen the auxiliary mounting bracket and the M-contactor. Move them aside.
- Step 6. Locate the two small drilled holes near the upper right of the chassis.
- Step 7. Position the Dynamic Braking kit so that the longer lead is toward the right side of the chassis. Mount it with the two mounting screws provided.
- Step 8. **For all regenerative MinPak Plus DC drives and non-regenerative MinPak Plus DC drives without a Reversing Contactor:** Connect the dynamic braking resistor to the normally closed (NC) contacts of the drive's M-contactor. These contacts are to the rear of the M-contactor. This places the resistor across the motor's armature when the M-contactor is de-energized. Refer to figures 2 and 5.
- Step 9. **For non-regenerative MinPak Plus DC drives with a Reversing Contactor:** Connect the dynamic braking resistor between corresponding normally closed (NC) contacts on the forward contactor and the reversing contactor. These contacts are to the rear of the contactors. This places the resistor across the motor armature (A1 and A2) when the contactors are de-energized. Refer to figures 4 and 6.
- Step 10. Verify the wiring of the Dynamic Braking resistor. Make sure connectors are securely fastened.
- Step 11. Reattach the terminal barrier and circuit breaker mounting bracket removed in step 4.
- Step 12. Reattach the cover to the drive.
- Step 13. Apply power and test the braking capability of the drive.

This completes the installation of the Dynamic Braking Kit for the MinPak Plus DC drives.

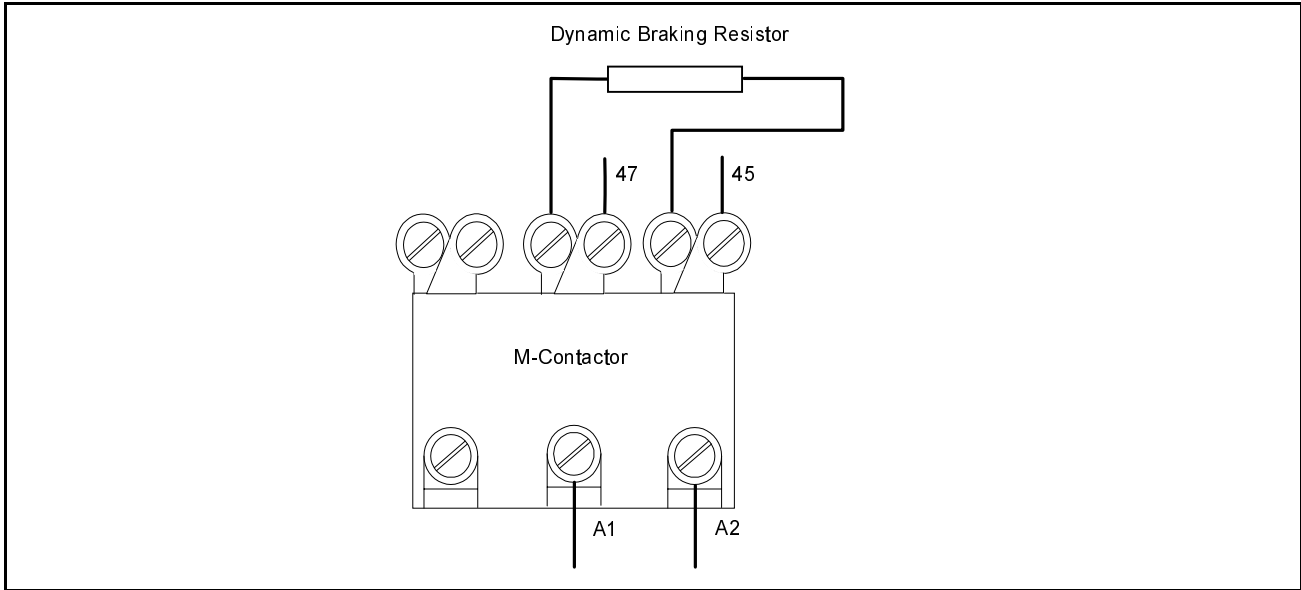

Figure 5 – Dynamic Braking Resistor Connections for MinPak Plus Drives Without a Reversing Contactor

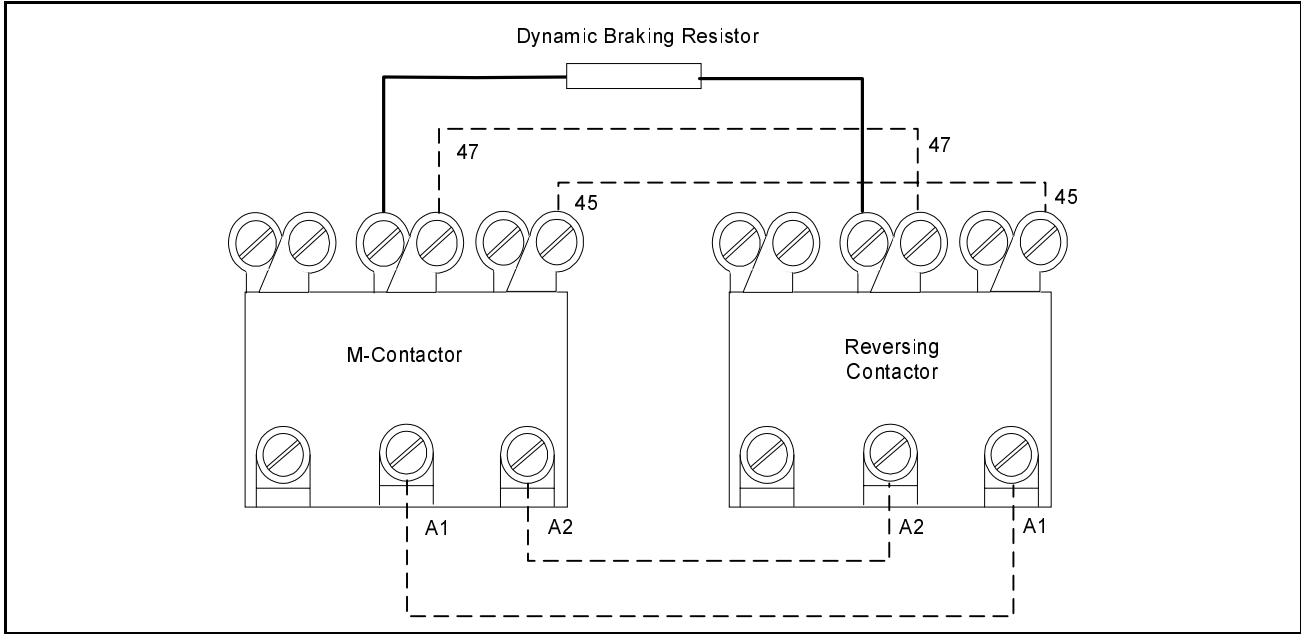

Figure 6 – Dynamic Braking Resistor Connections for MinPak Plus Drives With a Reversing Contactor

**Reach us now at [www.rockwellautomation.com](http://www.rockwellautomation.com)**

Wherever you need us, Rockwell Automation brings together leading brands in industrial automation including Allen-Bradley controls, Reliance Electric power transmission products, Dodge mechanical power transmission components, and Rockwell Software. Rockwell Automation's unique, flexible approach to helping customers achieve a competitive advantage is supported by thousands of authorized partners, distributors and system integrators around the world.



**Americas Headquarters**, 1201 South Second Street, Milwaukee, WI 53204, USA, Tel: (1) 414 382-2000, Fax: (1) 414 382-4444  
**European Headquarters SA/NV**, avenue Hermann Debroux, 46, 1160 Brussels, Belgium, Tel: (32) 2 663 06 00, Fax: (32) 2 663 06 40  
**Asia Pacific Headquarters**, 27/F Citicorp Centre, 18 Whitfield Road, Causeway Bay, Hong Kong, Tel: (852) 2887 4788, Fax: (852) 2508 1846

