



**GV3000/SE AC Bookshelf Drive  
Hardware Reference, Installation,  
and Troubleshooting  
Version 6.06**

---

Instruction Manual D2-3427-2

---

**Rockwell**  
**Automation**

The information in this manual is subject to change without notice.

Throughout this manual, the following notes are used to alert you to safety considerations:



**ATTENTION:** Identifies information about practices or circumstances that can lead to personal injury or death, property damage, or economic loss.

**Important:** Identifies information that is critical for successful application and understanding of the product.

The thick black bar shown on the outside margin of this page will be used throughout this instruction manual to signify new or revised text or figures.



**ATTENTION:** Only qualified electrical personnel familiar with the construction and operation of this equipment and the hazards involved should install, adjust, operate, or service this equipment. Read and understand this manual and other applicable manuals in their entirety before proceeding. Failure to observe this precaution could result in severe bodily injury or loss of life.

**ATTENTION:** Do not install or remove modification kits with power applied to the drive. Disconnect and lock out incoming power before attempting such installation or removal. Failure to observe this precaution could result in severe bodily injury or loss of life.

**ATTENTION:** DC bus capacitors retain hazardous voltages after input power has been disconnected. After disconnecting input power, wait five (5) minutes for the DC bus capacitors to discharge and then check the voltage with a voltmeter to ensure the DC bus capacitors are discharged before touching any internal components. Failure to observe this precaution could result in severe bodily injury or loss of life.

**ATTENTION:** The drive is capable of operating at and maintaining zero speed. The user is responsible for assuring safe conditions for operating personnel by providing suitable guards, audible or visual alarms, or other devices to indicate that the drive is operating or may operate at or near zero speed. Failure to observe this precaution could result in severe bodily injury or loss of life.

**ATTENTION:** The user must provide an external, hardwired emergency stop circuit outside of the drive circuitry. This circuit must disable the system in case of improper operation. Uncontrolled machine operation may result if this procedure is not followed. Failure to observe this precaution could result in bodily injury.

**ATTENTION:** The drive contains ESD- (Electrostatic Discharge) sensitive parts and assemblies. Static control precautions are required when installing, testing, servicing, or repairing the drive. Erratic machine operation and damage to, or destruction of, equipment can result if this procedure is not followed. Failure to observe this precaution can result in bodily injury.

**ATTENTION:** The user is responsible for conforming with all applicable local, national, and international codes. Failure to observe this precaution could result in damage to, or destruction of, the equipment.

DeviceNet is a trademark of Open DeviceNet Vendor Association.

ControlNet is a trademark of ControlNet International Ltd.

PROFIBUS is a trademark of PROFIBUS International.

GV3000, AutoMax, and Reliance are trademarks of Rockwell Automation.

©2000 Rockwell International Corporation

# CONTENTS

---

<b>Chapter 1</b>	<b>Introduction</b>	
1.1	Related Publications .....	1-1
1.2	Getting Assistance from Reliance Electric.....	1-1
<b>Chapter 2</b>	<b>About the Drive</b>	
2.1	Identifying the Drive.....	2-1
2.2	Understanding the Enclosure Rating: IP20 .....	2-2
2.3	2 to 15 Amp GV3000/SE Bookshelf Drive Component Locations .....	2-3
2.4	24 to 30 Amp GV3000/SE Bookshelf Drive Component Locations .....	2-4
2.5	43 Amp GV3000/SE Bookshelf Drive Component Locations .....	2-5
2.6	Regulator Board Description .....	2-6
2.6.1	Jumper Locations and Settings.....	2-7
2.6.1.1	Setting the Analog Input Speed Reference Jumper (J4) .....	2-7
2.6.1.2	Setting the Analog Output Jumper (J17).....	2-8
2.6.2	Terminal Strip.....	2-10
2.6.3	RS-232 Communication Port.....	2-10
2.6.4	Option Board Connector .....	2-11
2.6.5	Operator Interface Module (OIM) Connector.....	2-11
2.7	Keypad/Display.....	2-11
2.8	Output Relay Terminal Strip .....	2-12
2.9	Internal Braking Transistor .....	2-12
2.10	Optional Internal AC Mains Filter.....	2-12
2.11	Optional Equipment.....	2-12
<b>Chapter 3</b>	<b>Planning Before Installing</b>	
3.1	General Requirements for the Installation Site.....	3-1
3.1.1	Making Sure Environmental Conditions are Met.....	3-1
3.1.2	Determining Total Area Required Based on Drive Dimensions .....	3-3
3.1.3	Verifying the Site Provides for Recommended Air Flow Clearances ....	3-4
3.1.4	Verifying Power Module Input Ratings Match Supplied Power .....	3-5
3.2	Wiring Requirements for the Drive .....	3-5
3.2.1	Meeting Terminal Strip Input and Output Specifications .....	3-5
3.2.2	Determining Wire Size Requirements .....	3-5
3.2.2.1	Conduit Entry Opening Sizes for 24 to 43 Amp Bookshelf Drives	3-5
3.2.2.2	Recommended Power Wire Sizes .....	3-5
3.2.2.3	Recommended Control and Signal Wire Sizes.....	3-6
3.2.2.4	Recommended Motor Lead Lengths.....	3-6
3.2.2.5	Recommended Serial Communication Cable Lengths .....	3-8
3.2.3	Selecting Input Line Branch Circuit Fuses .....	3-8
3.2.4	Meeting Encoder Specifications (FVC Regulation Only).....	3-9
3.2.4.1	Encoder Wiring Guidelines .....	3-9
3.2.5	Verifying Power Module Output Current Rating Is Greater Than Motor Full Load Amps .....	3-9

<b>Chapter 4</b>	<b>Mounting the Drive, Grounding, and Finding Wire Routing Locations</b>	
4.1	Mounting the Drive .....	4-1
4.1.1	Verifying the Drive's Watts Loss Rating .....	4-1
4.2	Determining Input, Motor Output, Ground, and Control Wire Routing for the Drive .....	4-2
4.3	Grounding the Drive .....	4-2
<b>Chapter 5</b>	<b>Installing Input Power Wiring</b>	
5.1	Installing Transformers and Reactors (Optional) .....	5-1
5.2	Installing Fuses for Branch Circuit Protection .....	5-2
5.3	Installing a Required External/Separate Input Disconnect .....	5-2
5.4	Installing Power Wiring from the AC Input Line to the Drive's Power Terminals .....	5-2
<b>Chapter 6</b>	<b>Installing Output Power Wiring</b>	
6.1	Installing Output Contactors (Optional) .....	6-1
6.2	Installing Mechanical Motor Overload Protection (Optional) .....	6-1
6.3	Installing Output Wiring from the Drive Output Terminals to the Motor .....	6-1
<b>Chapter 7</b>	<b>Wiring the Regulator Board Terminal Strip and the Output Relay Terminal Strip</b>	
7.1	Stopping the Drive .....	7-4
7.1.1	Compliance with Machinery Safety Standard EN 60204-1:1992 .....	7-4
7.2	Wiring the Encoder Feedback Device (FVC Regulation Only) .....	7-5
7.3	Wiring the Signal and Control I/O .....	7-7
<b>Chapter 8</b>	<b>Wiring Optional User-Supplied Braking Resistors</b>	
8.1	Installation Guidelines .....	8-1
8.2	Selecting a Braking Resistor .....	8-3
8.3	Installing the Braking Resistor .....	8-4
<b>Chapter 9</b>	<b>Completing the Installation</b>	
9.1	Checking the Installation .....	9-1
9.2	Powering Up After Installation Is Complete .....	9-2
<b>Chapter 10</b>	<b>Troubleshooting the Drive</b>	
10.1	Test Equipment Needed To Troubleshoot .....	10-1
10.2	Drive Alarms and Faults .....	10-1
10.3	Verifying That DC Bus Capacitors Are Discharged .....	10-1
10.4	Checking Out the Drive with Input Power Off .....	10-4
10.5	Checking the Cooling Fans .....	10-7
10.6	Replacement Parts .....	10-7
<b>Appendix A</b>	<b>Technical Specifications</b> .....	A-1
<b>Appendix B</b>	<b>Compliance with Machinery Safety Standard EN 60204-1:1992</b> .....	B-1
<b>Appendix C</b>	<b>Compliance with Electromagnetic Compatibility Standards</b> .....	C-1
<b>Index</b>	.....	Index-1

# List of Figures

Figure 2.1 – Identifying the Drive Using the U. S. Model Number .....	2-1
Figure 2.2 – Identifying the Drive Using the European Stock Number .....	2-2
Figure 2.3 – 2 to 15 Amp Drive Component Locations.....	2-3
Figure 2.4 – 24 to 30 Amp Drive Component Locations.....	2-4
Figure 2.5 – 43 Amp Drive Component Locations.....	2-5
Figure 2.6 – Regulator Board Component Locations .....	2-6
Figure 2.7 – Jumper J4 Settings for Analog Input Speed Reference .....	2-8
Figure 2.8 – Jumper J17 Settings for Analog Outputs.....	2-9
Figure 2.9 – Typical Terminal Strip Connections.....	2-10
Figure 2.10 – Keypad/Display.....	2-11
Figure 2.11 – Output Relay Terminal Strip .....	2-12
Figure 3.1 – Dimensions for 2 to 30 Amp Drives .....	3-3
Figure 3.2 – Dimensions for 43 Amp Drives .....	3-4
Figure 3.3 – How to Calculate Motor Lead Lengths .....	3-7
Figure 4.1 – Wire Routing Locations for 2 to 15 Amp Drives.....	4-3
Figure 4.2 – Wire Routing Locations for 24 to 30 Amp Drives.....	4-4
Figure 4.3 – Wire Routing Locations for 43 Amp Drives.....	4-5
Figure 5.1 – Typical AC Input Electrical Connections.....	5-3
Figure 7.1 – Two-Wire Start/Stop Sample Control Wiring .....	7-3
Figure 7.2 – Three-Wire Start/Stop Sample Control Wiring.....	7-3
Figure 7.3 – Encoder Wiring Connections.....	7-6
Figure 7.4 – Wiring the Terminal Strip - Detail.....	7-7
Figure 8.1 – Braking Resistor Wiring Connections .....	8-4
Figure 10.1 – DC Bus Voltage Terminals (2 to 15 Amp Drives) .....	10-2
Figure 10.2 – DC Bus Voltage Terminals (24 to 30 Amp Drives) .....	10-3
Figure 10.3 – DC Bus Voltage Terminals (43 Amp Drives) .....	10-4



# List of Tables

Table 2.1 – Power Ratings .....	2-2
Table 2.2 – Standard Kits and Options .....	2-12
Table 3.1 – Environmental Conditions .....	3-2
Table 3.2 – Dimensions and Weights for 2 to 30 Amp Drives .....	3-3
Table 3.3 – Dimensions and Weight for 43 Amp Drives .....	3-4
Table 3.4 – Recommended Air Flow Clearances .....	3-4
Table 3.5 – Recommended Power Wire Sizes for 2 to 15 Amp Drives .....	3-5
Table 3.6 – Recommended Power Wire Sizes for 24 to 43 Amp Drives .....	3-6
Table 3.7 – Recommended Terminal Strip Wire Sizes .....	3-6
Table 3.8 – Recommended Motor Lead Lengths for Reliance Inverter Duty Motors....	3-7
Table 3.9 – Compatible Reactors .....	3-7
Table 3.10 – AC Input Fuse Selection Values .....	3-8
Table 7.1 – Encoder Connections (Regulator Terminals 4-9) .....	7-1
Table 7.2 – Analog Output Connections (Regulator Terminals 10 and 11) .....	7-1
Table 7.3 – Analog Speed/Torque Reference Connections (Regulator Terminals 12-15) .....	7-2
Table 7.4 – Digital Input Connections (Regulator Terminals 16-25) .....	7-2
Table 7.5 – Status Relay Connections (Relay Terminals 28-31) on the Output Relay Terminal Strip .....	7-2
Table 7.6 – Encoder Connections .....	7-5
Table 7.7 – Wiring Signal and Control I/O to the Regulator Board Terminal Strip....	7-7
Table 7.8 – Wiring the Output Relay Terminal Strip .....	7-14
Table 8.1 – Cable Cross-Sections for External Braking Resistors .....	8-2
Table 8.2 – Selecting a Braking Resistor .....	8-3
Table 8.3 – Wiring Connections for External Braking Resistor .....	8-4
Table 10.1 – Resistance Checks .....	10-5
Table 10.2 – Replacement Parts .....	10-7



## Introduction

This instruction manual describes GV3000/SE Bookshelf drive hardware. It does not cover the GV3000/SE drive software. For software information, refer to the GV3000/SE AC General Purpose (V/Hz) and Vector Duty Bookshelf Drive Software Start-Up and Reference Manual (D2-3426).

This manual is intended for qualified electrical personnel. It is organized according to a logical progression of steps to be followed to install and troubleshoot the drive.

GV3000/SE Bookshelf drives will typically be referenced by amps. If additional clarity is required, drive model numbers will also be included.

### 1.1 Related Publications

Refer to the following related publications as necessary for more information:

- D2-3426 GV3000/SE AC General Purpose (V/Hz) and Vector Duty Bookshelf Drive Software Start-Up and Reference Manual
- D2-3305 Motor Encoder Cable Kit
- D2-3308 AutoMax Network Communication Option Board
- D2-3348 Control and Configuration Software (CS3000)
- D2-3341 Super Remote Meter Interface (RMI) Board
- D2-3342 Operator Interface Module (OIM)
- D2-3390 ControlNet Network Communication Option Board

### 1.2 Getting Assistance from Reliance Electric

If you have any questions or problems with the products described in this instruction manual, contact your local Reliance Electric sales office. For technical assistance, call 1-800-726-8112.



## About the Drive

This chapter provides an overview of the drive including how to identify the drive, a description of the Regulator board, and the identification of major components of the drive.

The GV3000/SE AC Bookshelf drive is a PWM (pulse-width-modulated) drive that provides vector and general purpose regulation for a wide range of applications.

Using vector regulation, the drive can provide high dynamic response, maintain full rated motor torque to zero speed, and precisely control motor speed in both directions. The drive can provide this functionality either with encoder feedback (flux vector control or FVC) or without (sensorless vector control or SVC).

Using general purpose (volts/hertz or V/Hz) regulation, the drive is suited for a broad range of applications requiring adjustable speed control of motors.

### 2.1 Identifying the Drive

Each GV3000/SE Bookshelf drive can be identified by its U.S. model number or the European stock number. See figures 2.1 and 2.2. These numbers appear on the shipping label and on the drive's nameplate. Drive power ratings are provided in table 2.1.

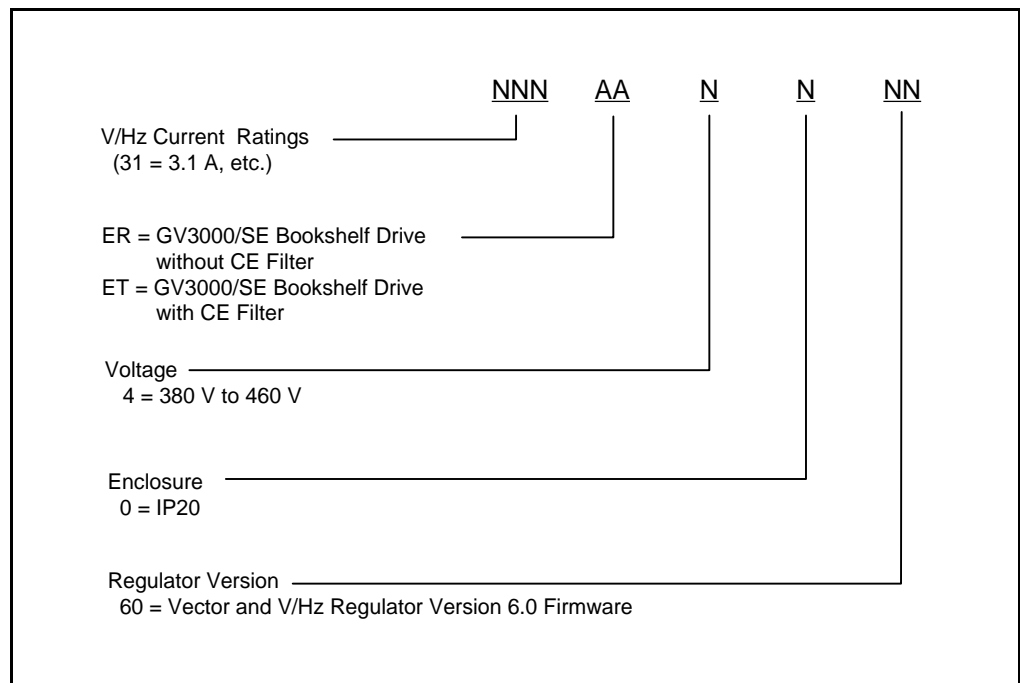

Figure 2.1 – Identifying the Drive Using the U. S. Model Number

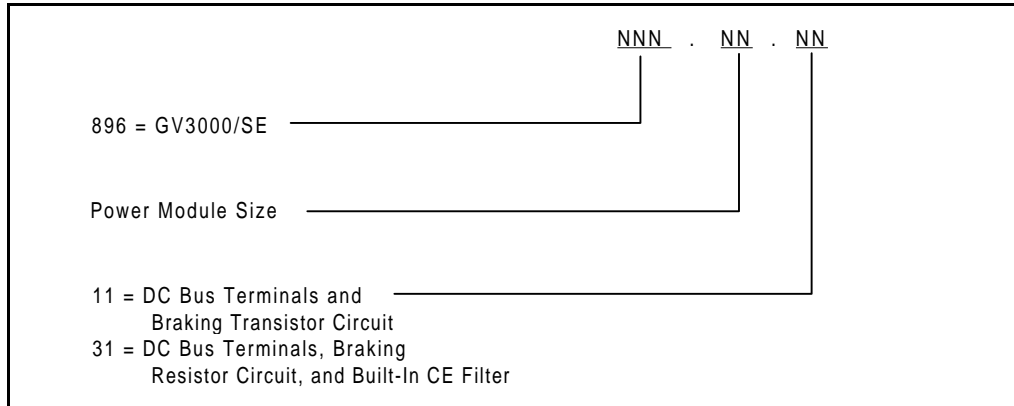

Figure 2.2 – Identifying the Drive Using the European Stock Number

Table 2.1 – Power Ratings

U.S. Model Number	European Stock Number	Input KVA	Input Amps*	Output Amps by Mode @ Carrier Frequency						Power Loss Watts (Full Load)
				V/Hz**			Vector**			
				2 kHz	4 kHz	8 kHz	2 kHz	4 kHz	8 kHz	
31ER40xx 31ET40xx	896.01.11 896.01.31	4.0 3.2	5 4	3.1	3.1	2.8	2.1	2.1	2.1	60
38ER40xx 38ET40xx	896.02.11 896.02.31	4.8 4.0	6 5	3.8	3.8	2.8	3.1	3.1	2.8	70
55ER40xx 55ET40xx	896.03.11 896.03.31	8.0 6.4	10 8	5.5	5.5	5.5	3.8	3.8	3.8	100
85ER40xx 85ET40xx	896.05.11 896.05.31	10.4 8.0	13 10	8.5	8.5	5.5	6.7	6.7	5.0	150
126ER40xx 126ET40xx	896.06.11 896.06.31	12.7 10.4	16 13	12.6	12.0	8.5	9.3	9.3	8.0	210
150ER40xx 150ET40xx	896.07.11 896.07.31	15.9 12.7	20 16	15.0	12.0	8.5	11.0	11.0	8.0	250
240ER40xx 240ET40xx	896.08.11 896.08.31	24.7 19.9	31 25	24.0	16.5	12.6	16.5	15.0	11.0	380
300ER40xx 300ET40xx	896.09.11 896.09.31	30.2 25.5	38 32	30.0	24.0	16.5	22.0	22.0	15.0	470
430ER40xx 430ET40xx	896.11.12 896.11.32	42.2 37.4	53 47	43.0	31.0	22.0	30.0	22.0	15.0	600

\*Input Voltage: 380 to 460 VAC (+/-10%)

\*\*With V/Hz regulation, 110% continuous output current capability. With vector regulation, 150% output current capability for one minute.

## 2.2 Understanding the Enclosure Rating: IP20

GV3000/SE Bookshelf drives have an IP20 rating. An IP rating designates the enclosure's level of protection. The first number (2) indicates the enclosure protects against solid objects greater than 12 mm. The second number (0) indicates that the enclosure is not water-tight. Note that the drive is intended for use inside a larger, user-supplied enclosure.

## 2.3 2 to 15 Amp GV3000/SE Bookshelf Drive Component Locations

The 2 to 15 amp GV3000/SE Bookshelf drives have the following main components. The numbered items listed below correspond to the numbers used in figure 2.3. Replacement parts are listed in chapter 10.

- |                                |                   |
|--------------------------------|-------------------|
| 1. Regulator PCB               | 4. Power PCB      |
| 2. Fan                         | 5. Keypad/Display |
| 3. Output Relay Terminal Strip |                   |

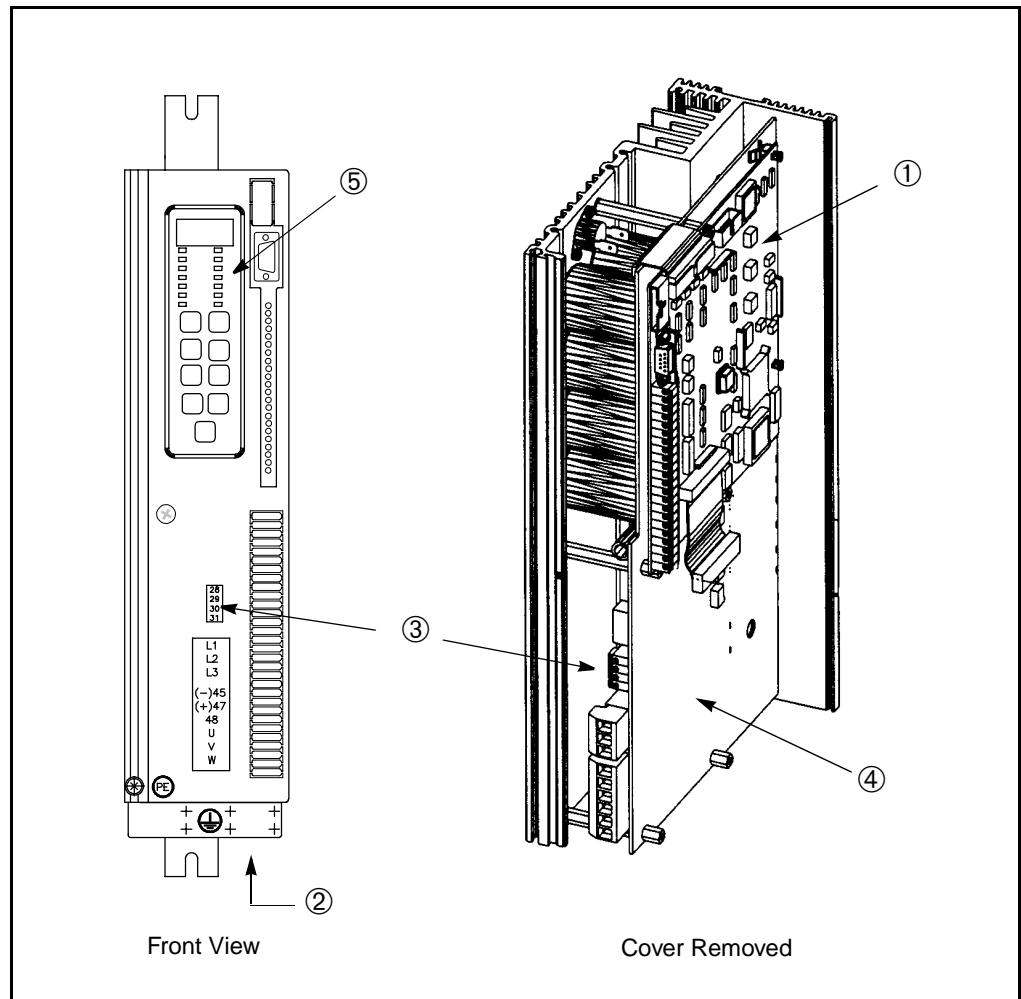

Figure 2.3 – 2 to 15 Amp Drive Component Locations

## 2.4 24 to 30 Amp GV3000/SE Bookshelf Drive Component Locations

The 24 to 30 amp GV3000/SE Bookshelf drives have the following main components. The numbered items listed below correspond to the numbers used in figure 2.4. Replacement parts are listed in chapter 10.

1. Regulator PCB
2. Fan
3. Output Relay Terminal Strip
4. Power PCB
5. Keypad/Display

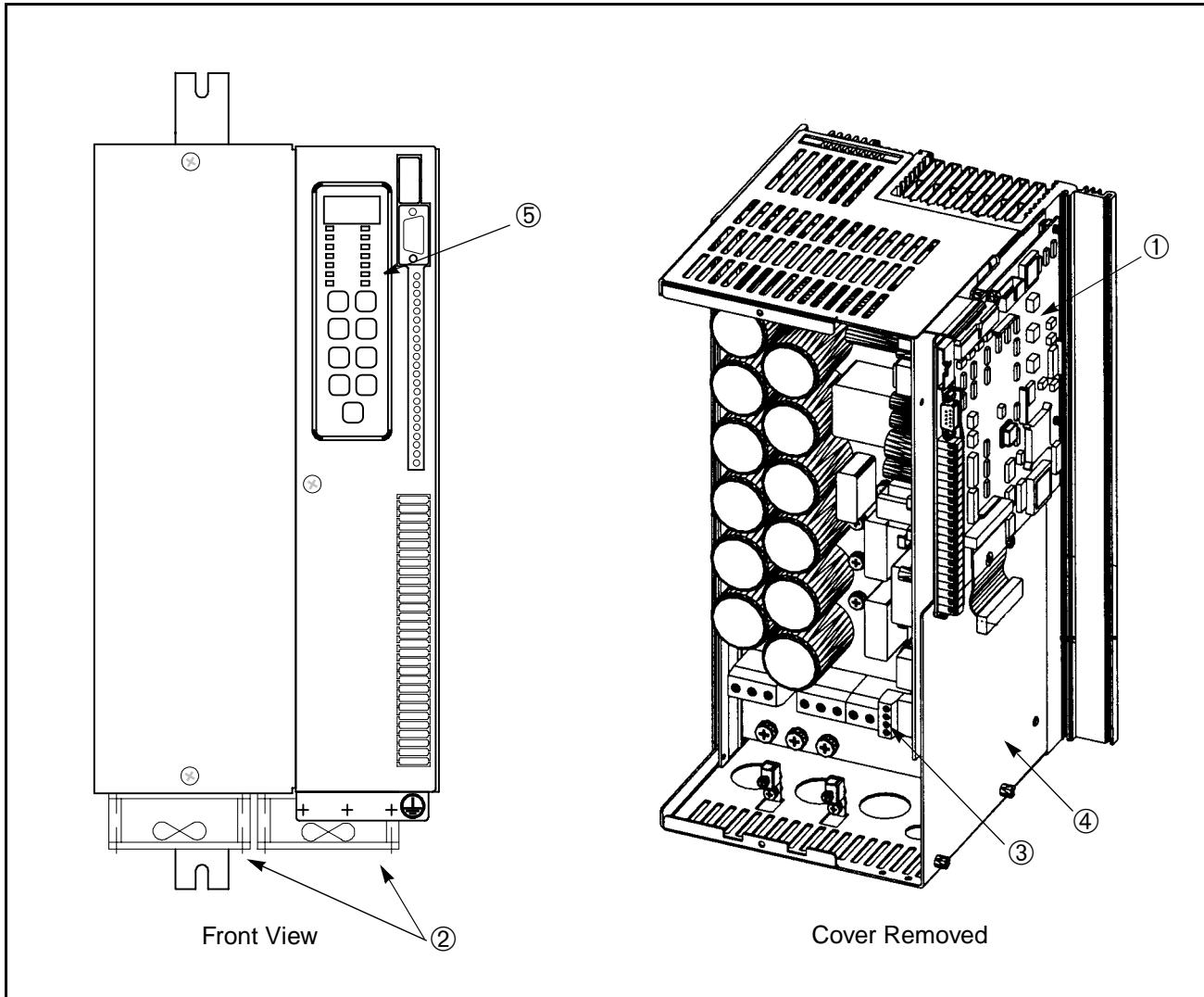

Figure 2.4 – 24 to 30 Amp Drive Component Locations

## 2.5 43 Amp GV3000/SE Bookshelf Drive Component Locations

The 43 amp GV3000/SE Bookshelf drives have the following main components. The numbered items listed below correspond to numbers used in figure 2.5. Replacement parts are listed in chapter 10.

- |                  |                                |
|------------------|--------------------------------|
| 1. Regulator PCB | 3. Output Relay Terminal Strip |
| 2. Fan           | 4. Keypad/Display              |

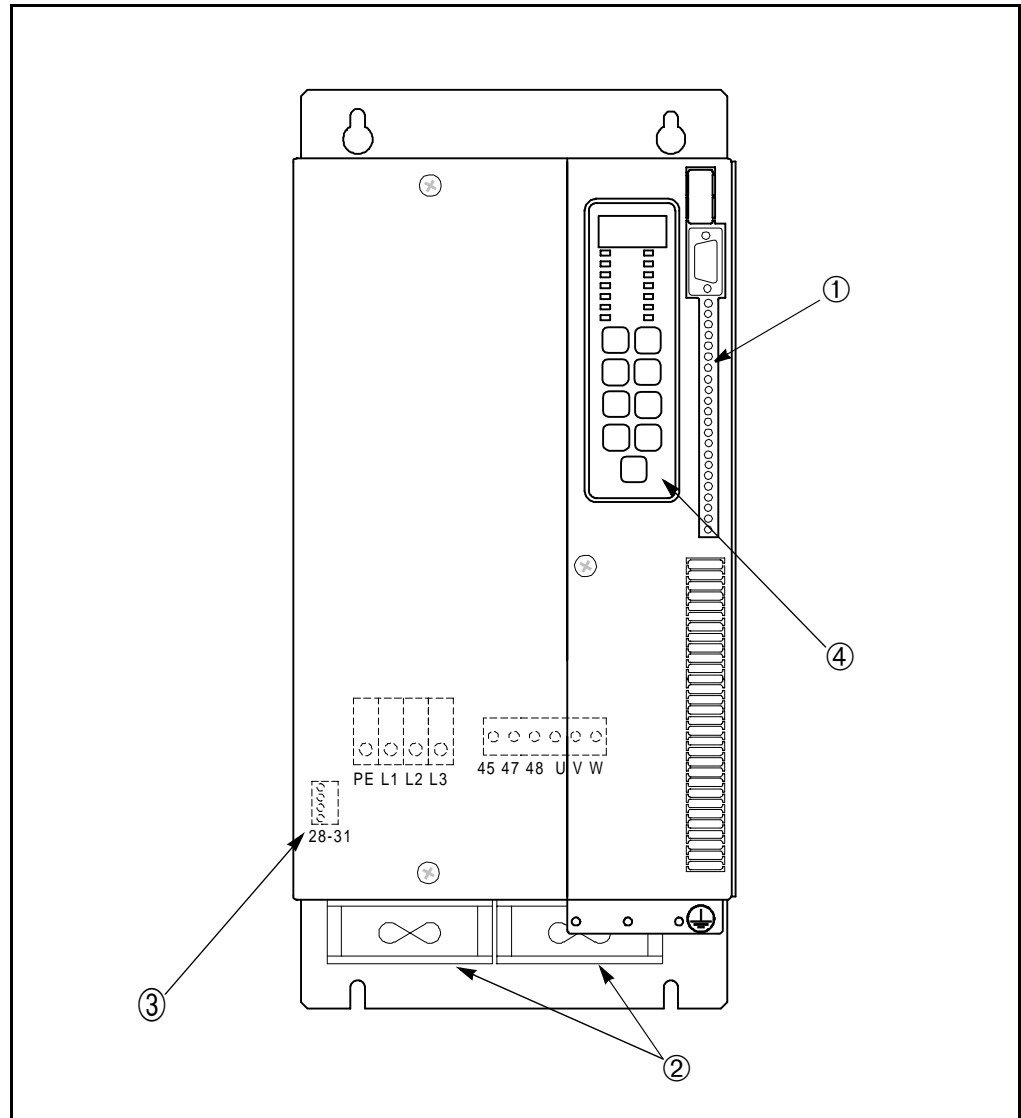

Figure 2.5 – 43 Amp Drive Component Locations

## 2.6 Regulator Board Description

Drive regulation is performed by a microprocessor on the Regulator board. See figure 2.6. Drive operation is adjusted by the parameters entered through the keypad. The Regulator board accepts power circuit feedback signals and an external speed reference signal, as well as data from an encoder that is attached to the motor when set up for FVC regulation.

The Regulator board provides PWM gating signals to the IGBT power devices. Based on the output of the control loop, the regulator sends PWM gating signals through the current feedback section of the Power board to the isolated gate drivers. These drivers switch the Insulated Gate Bi-polar Transistors (IGBTs), producing a PWM waveform that corresponds to the speed (FVC regulation) or frequency (V/Hz regulation) reference. The IGBTs can be switched at either a 2, 4, or 8 kHz carrier frequency.

The Regulator board components are shown in figure 2.6 and described in the following sections.

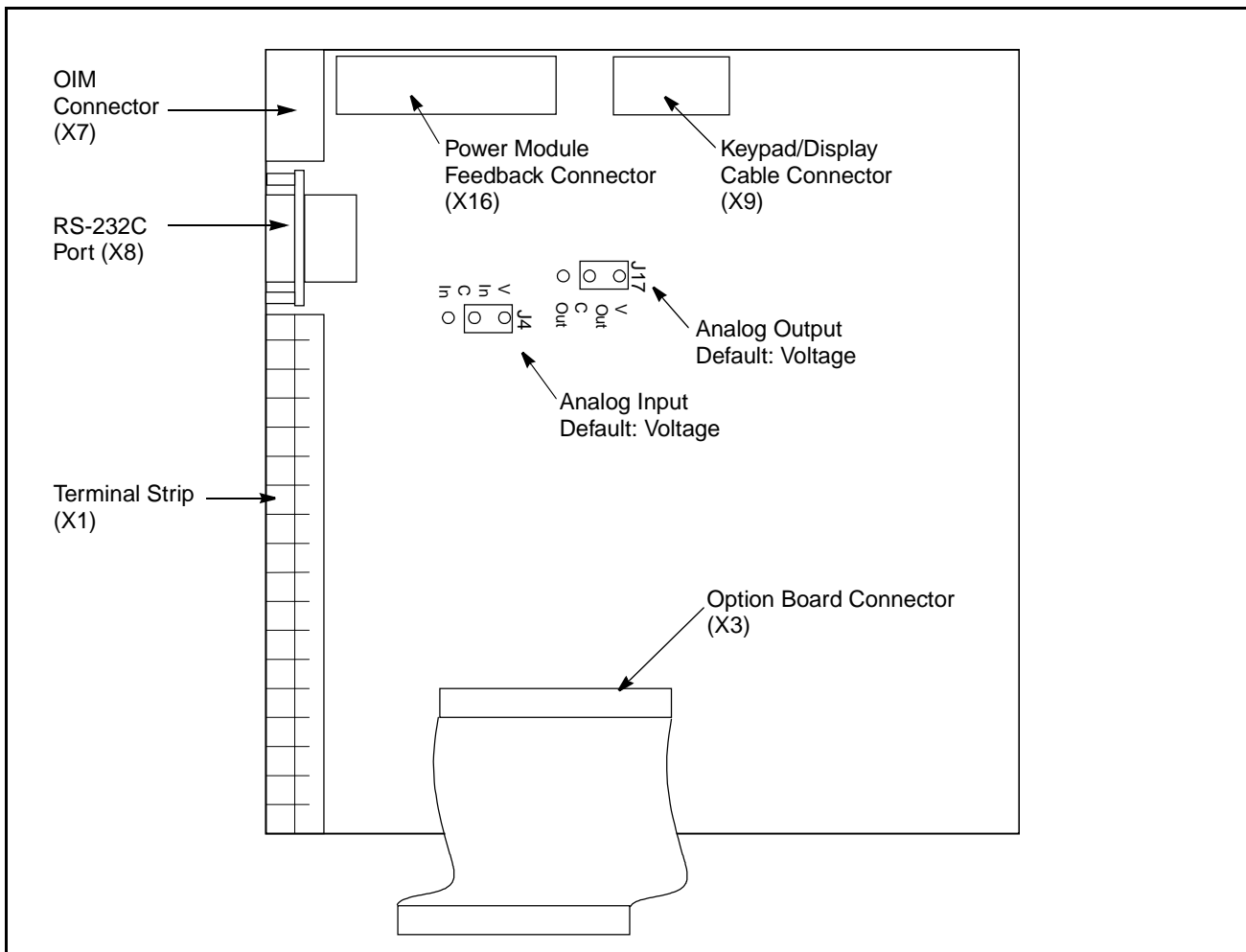

Figure 2.6 – Regulator Board Component Locations

## 2.6.1 Jumper Locations and Settings

Jumpers J4 and J17 on the Regulator board are factory-set for voltage in and voltage out signals. Refer to figure 2.6 for their locations on the Regulator board. If you need to change the jumpers' settings, use the following procedures.



**ATTENTION:** Do not alter the setting of any jumper not described in this instruction manual. Failure to observe this precaution could result in damage to, or destruction of, the equipment.

### 2.6.1.1 Setting the Analog Input Speed Reference Jumper (J4)

Jumper J4 is the analog speed/torque (U.000) reference jumper. This jumper selects either +/-10 VDC or 0-20 mA input. Parameters P.009, P.010, and P.011 are used in conjunction with the jumper.

Note that if the position of jumper J4 is changed after the parameters are programmed, the software will not recognize that the input reference or polarity has been changed. Be sure to verify that parameters P.009, P.010, and P.011 are correct before starting the drive. Refer to the GV3000/SE Bookshelf Drive Software Start-Up and Reference manual for more information about these parameters.

Use the following procedure to set jumper J4:



**ATTENTION:** DC bus capacitors retain hazardous voltages after input power has been disconnected. After disconnecting input power, wait five (5) minutes for the DC bus capacitors to discharge and then check the voltage with a voltmeter to ensure the DC bus capacitors are discharged before touching any internal components. Failure to observe this precaution could result in severe bodily injury or loss of life.

Step 1. Disconnect, lock out, and tag all incoming power to the drive.

Step 2. Wait five minutes for the DC bus capacitors to discharge.

Step 3. Disconnect any wiring from the face of the drive.

**Important:** The cover is connected to the drive by the keypad/display cable. To disconnect the cover, use the procedure below. Do not remove the keypad/display.

Step 4. Remove the cover as follows:

- a. Unscrew the attaching screw on the cover.
- b. Lift the cover and carefully take it out of the heatsink as far as the flat ribbon keypad cable will allow. This cable connects the display with the Regulator board.
- c. Use a screwdriver to slide the cable out of the connector on the Regulator board to completely detach the cover.

Step 5. 24 to 43 A drives only: Remove the front panel by unscrewing the two attaching screws.

Step 6. Verify that the DC bus voltage is zero before touching any internal components by following the procedure in section 10.3.

Step 7. Locate jumper J4 on the Regulator board. Refer to figure 2.6.

Step 8. Locate pin 1 on jumper J4. Move the jumper to the desired setting as shown in figure 2.7.

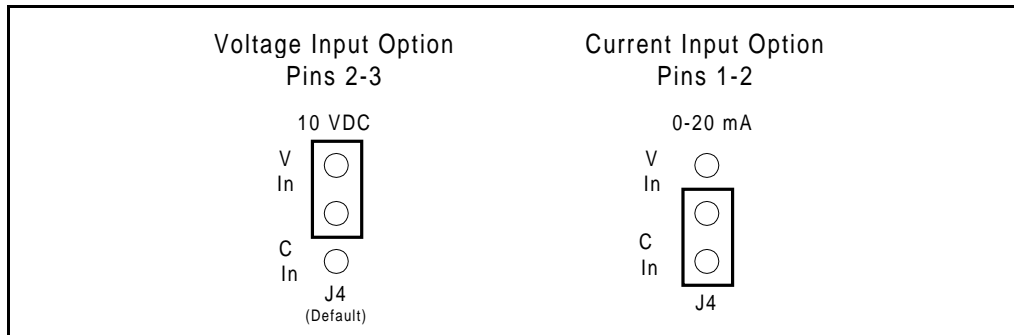

Figure 2.7 – Jumper J4 Settings for Analog Input Speed Reference

Step 9. Reattach the cover. For 24 to 43 A drives, reattach the front panel before reattaching the cover.

**Important:** Check that the display cable is reconnected to the Regulator board. You will need to fold and route the cable under the heatsink before replacing the cover.

Step 10. Reconnect wiring to the faceplate of the drive.

Step 11. Reapply input power.

Step 12. Verify that Terminal Strip Analog Input Offset (P.009), Terminal Strip Analog Input Gain (P.010), and Terminal Strip Analog Input Configure (P.011) are correctly set.

Note that the jumper settings must match the software settings; otherwise, the reference value may differ from what is expected. Refer to the GV3000/SE Bookshelf Drive Software Start-Up and Reference manual for more information.

### 2.6.1.2 Setting the Analog Output Jumper (J17)

Jumper J17 is the analog output jumper. This jumper selects either a 0-10 VDC or 4-20 mA scaled signal output that is programmable to be proportional to either speed or torque using parameter P.012. Refer to the GV3000/SE Bookshelf Drive Software Start-Up and Reference manual for more information about this parameter. The analog output signal is available through the terminal strip.

The jumper only selects a 0-10 VDC source voltage or 4-20 mA sink current to represent speed or torque. Note that the 4-20 mA current selection requires an external 12 VDC power supply for operation as shown in table 7.6.

Use the following procedure to set jumper J17:



**ATTENTION:** DC bus capacitors retain hazardous voltages after input power has been disconnected. After disconnecting input power, wait five (5) minutes for the DC bus capacitors to discharge and then check the voltage with a voltmeter to ensure the DC bus capacitors are discharged before touching any internal components. Failure to observe this precaution could result in severe bodily injury or loss of life.

- Step 1. Disconnect, lock out, and tag all incoming power to the drive.
- Step 2. Wait five minutes for the DC bus capacitors to discharge.
- Step 3. Disconnect any wiring from the faceplate of the drive.
- Important:** The cover is connected to the drive by the keypad/display cable. To disconnect the cover, use the procedure below. Do not remove the keypad/display.
- Step 4. Remove the cover as follows:
- Unscrew the attaching screw on the cover.
  - Lift the cover and carefully take it out of the heatsink as far as the flat ribbon keypad cable will allow. This cable connects the display with the Regulator board.
  - Use a screwdriver to slide the cable out of the connector on the Regulator board to completely detach the cover.
- Step 5. 24 to 43 A drives only: Remove the front panel by unscrewing the two attaching screws.
- Step 6. Verify that the DC bus voltage is zero by following the procedure in section 10.3.
- Step 7. Locate jumper J17 on the Regulator board. Refer to figure 2.6.
- Step 8. Locate pin 1 on jumper J17. Move the jumper to the desired setting as shown in figure 2.8.

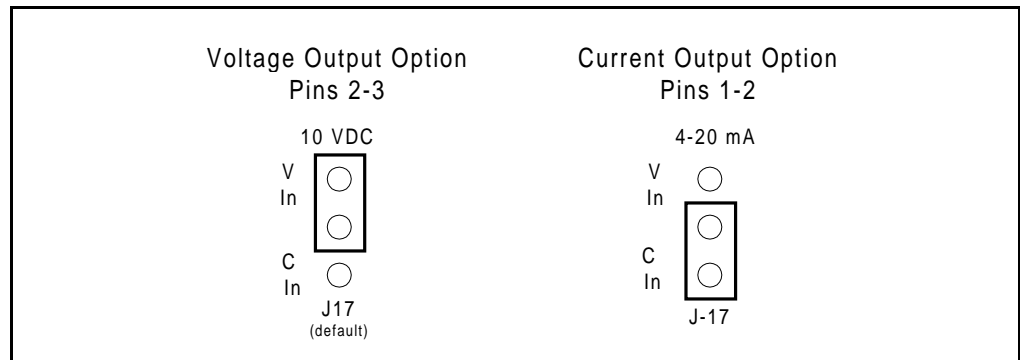

Figure 2.8 – Jumper J17 Settings for Analog Outputs

- Step 9. Reattach the cover. For 24 to 43 A drives, reattach the front panel before reattaching the cover.
- Important:** Check that the display cable is reconnected to the Regulator board. You will need to fold and route the cable under the heatsink before replacing the cover.
- Step 10. Reconnect wiring to the faceplate of the drive.
- Step 11. Reapply input power.
- Step 12. Verify that parameter P.012 is set correctly for either speed or current.

## 2.6.2 Terminal Strip

The terminal strip on the Regulator board provides terminals for connecting customer I/O devices. See figures 2.6 and 2.9. The following terminals are provided:

- Terminals 4-9: Encoder connections
- Terminals 10-11: Analog output connections
- Terminals 12-15: Analog speed/torque reference connections
- Terminals 16-25: 24V DC digital input connections

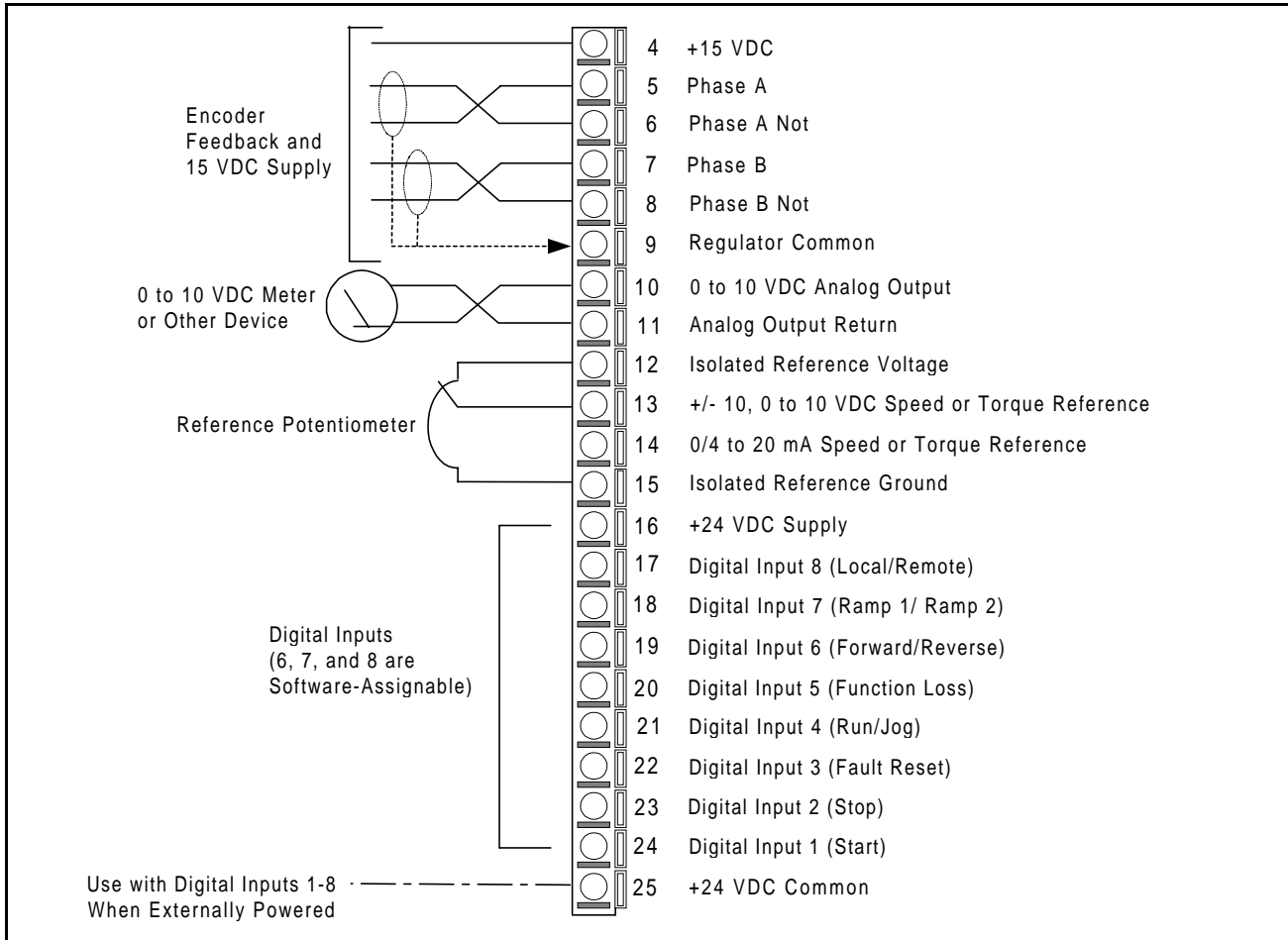

Figure 2.9 – Typical Terminal Strip Connections

## 2.6.3 RS-232 Communication Port

The Regulator board contains a 9-pin D-shell RS-232 communication port (X8). See figure 2.6. This port provides RS-232 communication between the GV3000/SE drive and a personal computer running the Control and Configuration (CS3000) Software. Refer to instruction manual D2-3348 for more information about the CS3000 software.

### 2.6.4 Option Board Connector

The flat-ribbon cable connector (X3) on the bottom of the Regulator board is a parallel bus connection port that provides a means of attaching optional boards such as the DeviceNet Option board, the RMI board, the AutoMax Network Option board, or similar boards to the GV3000/SE drive. See figure 2.6. Refer to the appropriate board instruction manual for more information. Refer to section 2.11 of this manual for more information on optional drive kits.

### 2.6.5 Operator Interface Module (OIM) Connector

Flat-ribbon connector X7 provides a means of attaching the optional Operator Interface Module (OIM). The OIM is available for use as a remote keypad for the drive. Refer to the Operator Interface Module manual (D2-3342) for more information.

## 2.7 Keypad/Display

The front panel keypad/display is used to program and operate the drive. See figure 2.10. The four-character display is used to indicate drive parameters, parameter values, and error codes. The fourteen single LEDs indicate drive status and operating mode, as well as identify drive outputs whose values are displayed on the four-character display.

Refer to the GV3000/SE Bookshelf Drive Software Start-Up and Reference manual (D2-3426) for more information about the keypad/display.

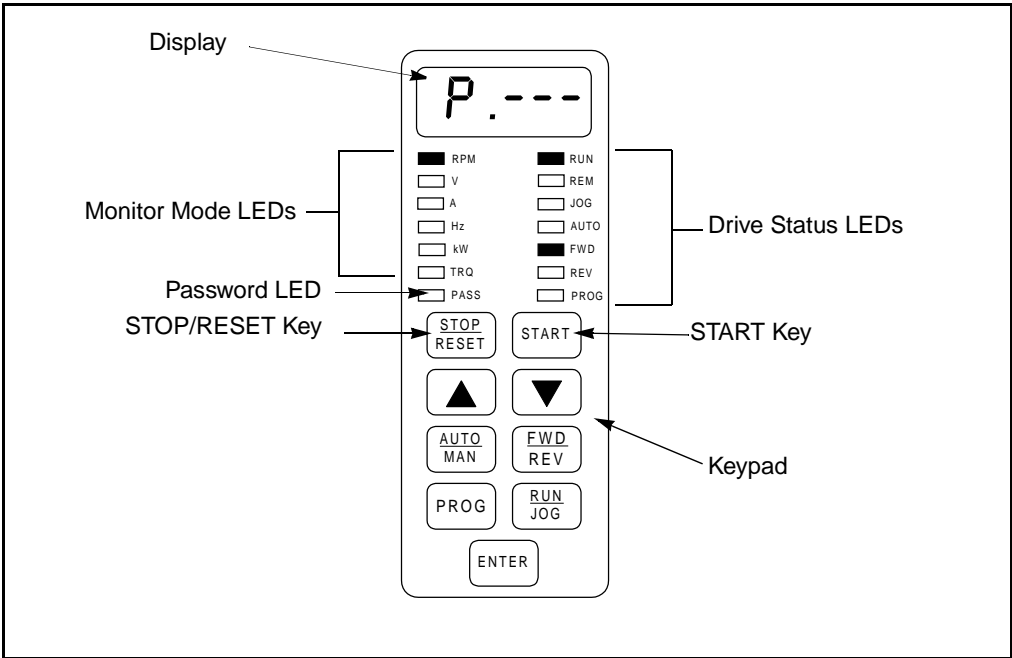

Figure 2.10 – Keypad/Display

## 2.8 Output Relay Terminal Strip

The output relay terminal strip, located on the Power board, provides a set of Form A and B contacts. These contacts are under the control of the user via programmable parameters. A Form A or B transition can be used to indicate drive status. The contacts are rated for 2 amps resistive load at 250 VAC/ 30 VDC. See figure 2.11

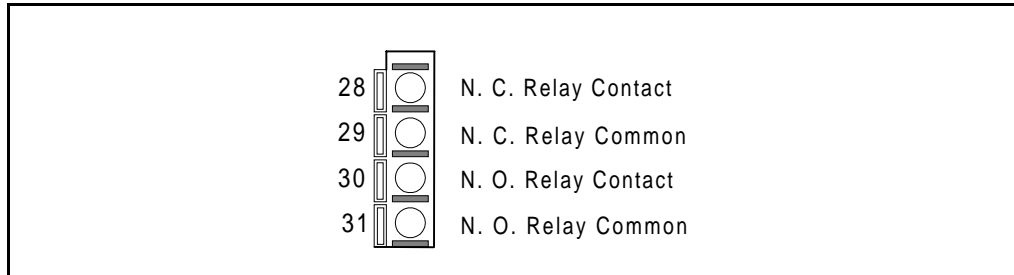

Figure 2.11 – Output Relay Terminal Strip

## 2.9 Internal Braking Transistor

An internal braking transistor connects externally mounted, user-supplied braking resistors to the DC bus and prevents DC bus overvoltage faults. The resistor switches on during motor regeneration. See chapter 8 for more information.

## 2.10 Optional Internal AC Mains Filter

A built-in line filter limits radio frequency emission to EMC permitted values. It provides the same function as a line reactor.

An AC Mains Filter is required if the installation must be in compliance with the European Community Electromagnetic Compatibility Standard. See Appendix C for more information.

## 2.11 Optional Equipment

Table 2.2 lists standard GV3000/SE kits and options.

Table 2.2 – Standard Kits and Options

Description	Model Number	Instruction Manual
Motor Encoder Cable	2TC3025 2TC3075 2TC4025 2TC4075 2TC4100 2TC4300	D2-3305
ControlNet Network Option Board	2CN3000	D2-3390
InterBus Network Option Board	2NB3000	49'1333
AutoMax Network Option Board with 762mm (30") of Cable	2AX3000	D2-3308
AutoMax RS-232 Adapter Cable	2CA3001	D2-3348

Table 2.2 – Standard Kits and Options (Continued)

Description	Model Number	Instruction Manual
Super Remote Meter Interface (RMI)	2SI3000E	D2-3341
DeviceNet Network Option Board	2DV3000	MAN0096-03
Operator Interface Module (OIM)	2RK3000	D2-3342
CS3000 Control and Configuration Software	2CS3000	D2-3348
CS3000 RS-232 Computer Cable	2CA3000	D2-3348
115 VAC Interface Option Board	2LB3000	D2-3376
PROFIBUS™ Network Option Board	2PB3000	49'1355



## Planning Before Installing

This chapter describes how to plan a GV3000/SE Bookshelf drive installation.



**ATTENTION:** Only qualified electrical personnel familiar with the construction and operation of this equipment and the hazards involved should install, adjust, operate, or service this equipment. Read and understand this manual and other applicable manuals in their entirety before proceeding. Failure to observe this precaution could result in severe bodily injury or loss of life.

**ATTENTION:** When the level-sense start feature is enabled (P.054 = ON), the user must ensure that automatic start up of the driven equipment will not cause injury to operating personnel or damage to the driven equipment. In addition, the user is responsible for providing suitable audible or visual alarms or other devices to indicate that this function is enabled and the drive may start at any moment. Refer to the GV3000/SE Bookshelf Drive Software Start-Up and Reference manual (D2-3426) for additional information. Failure to observe this precaution could result in severe bodily injury or loss of life.

**ATTENTION:** Use of power correction capacitors on the output of the drive can result in erratic operation of the motor, nuisance tripping, and/or permanent damage to the drive. Remove power correction capacitors before proceeding. Failure to observe this precaution could result in damage to, or destruction of, the equipment.

**ATTENTION:** The user is responsible for conforming with all applicable local, national, and international codes. Failure to observe this precaution could result in damage to, or destruction of, the equipment.

### 3.1 General Requirements for the Installation Site

It is important to properly plan before installing a GV3000/SE Bookshelf drive to ensure that the drive's environment and operating conditions are satisfactory. Note that no devices are to be mounted behind the drive. This area must be kept clear of all control and power wiring. Read the following recommendations before continuing with drive installation.

#### 3.1.1 Making Sure Environmental Conditions are Met

Before deciding on an installation site, consider the following guidelines:

- Verify that drives can be kept clean, cool, and dry.
- The area chosen should allow the space required for proper air flow as defined in section 3.1.3.
- Be sure that drives are away from oil, coolants, or other airborne contaminants.

- Do not install the drive above 1000 meters (3300 feet) without derating output power. For every 91.4 meters (300 feet) above 1000 meters (3300 feet), derate the output current 1%.
- Verify that the drive location will meet the environmental conditions specified in table 3.1.

Table 3.1 – Environmental Conditions

Condition	Specification
Operating Temperature (Ambient)	0° to +40°C (32° to 104°F) coolant air inlet temperature at heatsink  Derating factor at 45°C (113°F) ambient: Output current by 7.5%  Derating factor at 50°C (122°F) ambient: Output current by 15%
Storage Temperature (Ambient)	-25°C to +55°C (-77° to +131°F)
Transportation Temperature (Ambient)	-25°C to +70°C (-77° to +158°F) (+70°C (+158°F) during max. 24 hrs)
Humidity	Maximum: 50% at 40°C (104°F) unlimited  Maximum: 90% at 20°C (68°F) during maximum 30 days/year  75% average  No condensation

### 3.1.2 Determining Total Area Required Based on Drive Dimensions

Drive dimensions and weights are listed in table 3.2. Overall drive dimensions are illustrated in figure 3.1 as an aid in calculating the total area required by the drive.

Table 3.2 – Dimensions and Weights for 2 to 30 Amp Drives

U.S. Model Number	European Stock Number	Physical Dimensions in mm (in)					Weight	
		Width Dim A mm (in)	Height Dim B mm (in)	Width Dim C mm (in)	Mounting Height Dim D mm (in)	Depth Dim E mm (in)	kg	lb
31ER40xx 31ET40xx	896.01.11 896.01.31	95 (3.74)	378 (14.88)	38 (1.50)	422 (16.61)	200 (7.87)	5.5	12
38ER40xx 38ET40xx	896.02.11 896.02.31	95 (3.74)	378 (14.88)	38 (1.50)	422 (16.61)	200 (7.87)	5.5	12
55ER40xx 55ET40xx	896.03.11 896.03.31	95 (3.74)	378 (14.88)	38 (1.50)	422 (16.61)	200 (7.87)	5.5	12
85ER40xx 85ET40xx	896.05.11 896.05.31	95 (3.74)	378 (14.88)	38 (1.50)	422 (16.61)	200 (7.87)	5.5	12
126ER40xx 126ET40xx	896.06.11 896.06.31	95 (3.74)	378 (14.88)	38 (1.50)	422 (16.61)	200 (7.87)	5.5	12
150ER40xx 150ET40xx	896.07.11 896.07.31	95 (3.74)	378 (14.88)	38 (1.50)	422 (16.61)	200 (7.87)	5.5	12
240ER40xx 240ET40xx	896.08.11 896.08.31	195 (7.68)	374 (14.72)	61 (2.40)	422 (16.61)	200 (7.87)	10	22
300ER40xx 300ET40xx	896.09.11 896.09.31	195 (7.68)	374 (14.72)	61 (2.40)	422 (16.61)	200 (7.87)	10	22

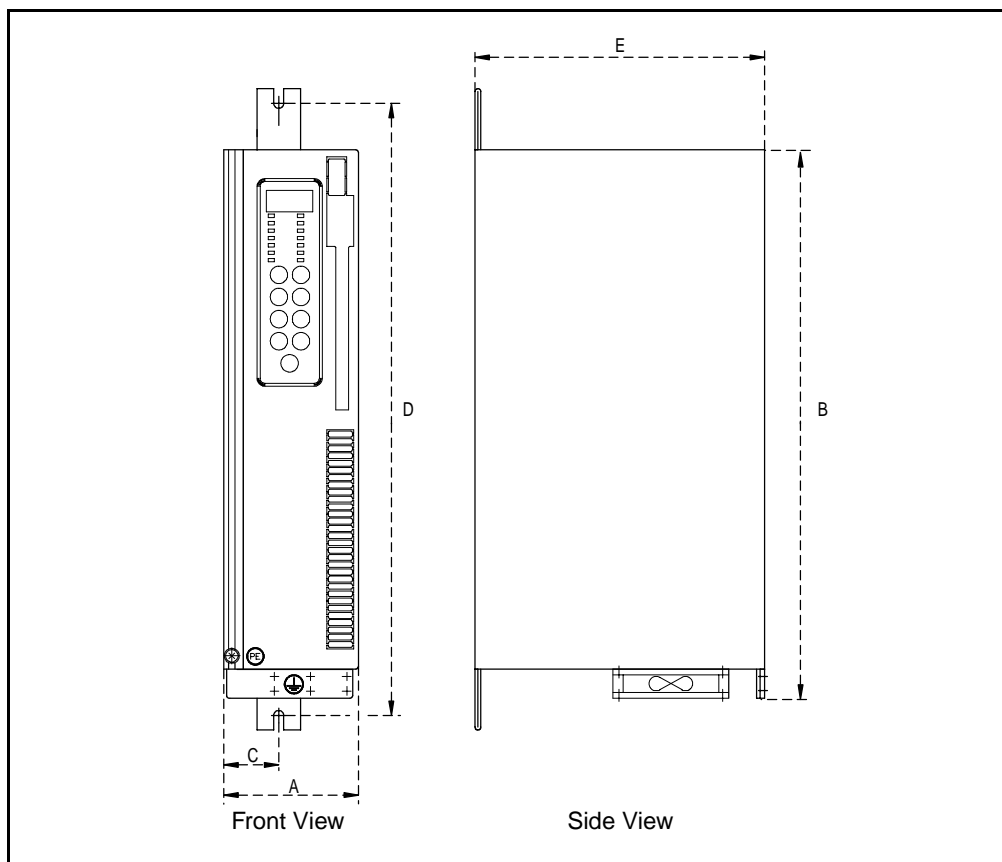

Figure 3.1 – Dimensions for 2 to 30 Amp Drives

Table 3.3 – Dimensions and Weight for 43 Amp Drives

U.S. Model Number	European Stock Number	Physical Dimensions in mm (in)					Weight	
		Width Dim A mm (in)	Height Dim B mm (in)	Width Dim C mm (in)	Mounting Height Dim D mm (in)	Depth Dim E mm (in)	kg	lb
430ER40xx 430ET40xx	896.11.12 896.11.32	214 (8.42 )	374 (14.72)	150 (5.90)	422 (16.61)	200 (7.87)	16.5	36

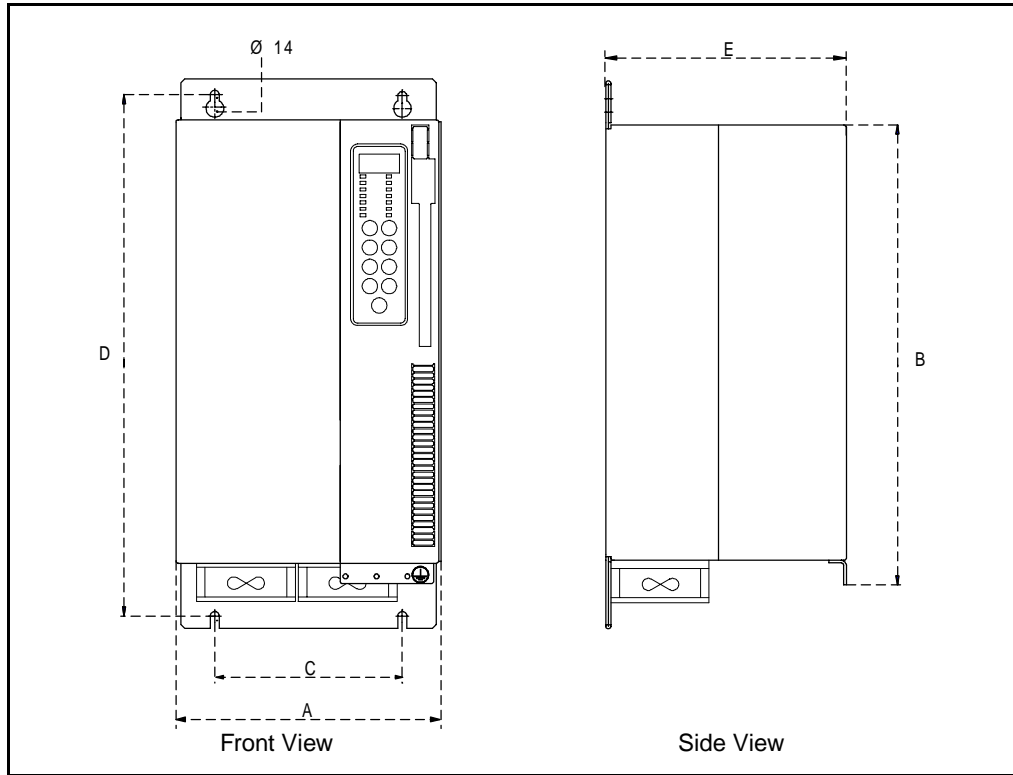

Figure 3.2 – Dimensions for 43 Amp Drives

### 3.1.3 Verifying the Site Provides for Recommended Air Flow Clearances

Be sure there is adequate clearance for air circulation around the drive. For best air movement, do not mount GV3000/SE Bookshelf drives directly above each other. Note that no devices are to be mounted behind the drive. This area must be kept clear of all control and power wiring.

When mounting the drive within a cabinet, maintain the minimum clearances shown in table 3.4 to allow adequate air circulation around and through the drive.

Table 3.4 – Recommended Air Flow Clearances

	Minimum Clearance	
Above and below the Bookshelf drive	100 mm	4 in
Between the Bookshelf drive and side cabinet walls	20 mm	.75 in
Between Bookshelf drives	5 mm	.25 in
Between other larger drives or heat-producing devices	40 mm	1.5 in

### 3.1.4 Verifying Power Module Input Ratings Match Supplied Power

It is important to verify that plant power will meet the input power requirements of the drive's Power Module circuitry. Refer to table 2.1 for input power rating specifications. Be sure input power to the drive corresponds to the drive nameplate voltage and frequency.

## 3.2 Wiring Requirements for the Drive

Certain drive requirements should be checked before continuing with the drive installation. Wire sizes, branch circuit protection, encoder feedback (for FVC regulation), and E-stop wiring (see chapter 7) are all areas that need to be evaluated.

### 3.2.1 Meeting Terminal Strip Input and Output Specifications

The terminal strip on the Regulator board provides terminals for 24 VDC power for the eight remote control inputs. Refer to tables A.3 and A.4 for control input and output specifications.

### 3.2.2 Determining Wire Size Requirements

Wire size should be determined based on the size of conduit openings, and applicable local, national, and international codes (e.g., NEC/CEC regulations).



**ATTENTION:** The user is responsible for conforming with all applicable local, national, and international codes. Failure to observe this precaution could result in damage to, or destruction of, the equipment.

#### 3.2.2.1 Conduit Entry Opening Sizes for 24 to 43 Amp Bookshelf Drives

It is important to determine the size of the conduit openings so that the wire planned for a specific entry point will fit through the opening. Conduit opening sizes are shown in figures 4.2 and 4.3.

#### 3.2.2.2 Recommended Power Wire Sizes

Input power wiring should be sized according to applicable codes to handle the drive's continuous-rated input current. Output wiring should be sized according to applicable codes to handle the drive's continuous-rated output current. See tables 3.5 and 3.6 for recommended power wire sizes.

Table 3.5 – Recommended Power Wire Sizes for 2 to 15 Amp Drives



Type of Wiring	Terminals	Size of Wire (Maximum)
AC Input Power	L1, L2, L3, PE	12 AWG, 6 mm <sup>2</sup>
Output Power	U, V, W	
DC Bus Output	45(-), 47(+), 48	
Ground	PE 	

Table 3.6 – Recommended Power Wire Sizes for 24 to 43 Amp Drives

Type of Wiring	Terminals	Size of Wire (Maximum)
AC Input Power and Ground	L1, L2, L3 PE	6 AWG, 16 mm <sup>2</sup>
Output Power and Ground	U, V, W 	
DC Bus Output, Braking Resistor	45(-), 47(+) 48(-), 47(+)	

### 3.2.2.3 Recommended Control and Signal Wire Sizes

The recommended wire sizes to connect I/O signals to the terminal strip on the Regulator board are shown in table 3.7. Recommended terminal tightening torque is 9.5 Newton-meters (85 in-lb). Operator controls can be up to 303 meters (1000 feet) from the drive.

Table 3.7 – Recommended Terminal Strip Wire Sizes

Terminals	Wire Size
4-25 (Regulator Board Terminal Strip)	20 AWG to 14 AWG, 0.5 to 2 mm <sup>2</sup>
28-31 (Output Relay Terminal Strip)	

### 3.2.2.4 Recommended Motor Lead Lengths

To reduce line disturbances and noise, motor lead length should not exceed 76 meters (250 feet) for any non-Reliance Electric motor or any non-inverter duty motor.

When total lead length exceeds 76 meters (250 feet), nuisance trips can occur caused by capacitive current flow to ground. Note that these capacitively-coupled currents should be taken into consideration when working in areas where drives are running. If the motor lead length must exceed these limits, the addition of output line reactors or other steps must be taken to correct the problem. Refer to table 3.9 for a list of compatible reactors.

For Reliance Electric inverter duty motors, use the recommended lead lengths shown in table 3.8 as a guideline.

Your application may be restricted to a shorter lead length due to:

- the type of wire
- the placement of wire (for example, in conduit or a cable tray)
- the type of line reactor
- the type of motor.

Figure 3.3 illustrates how to calculate motor lead lengths.

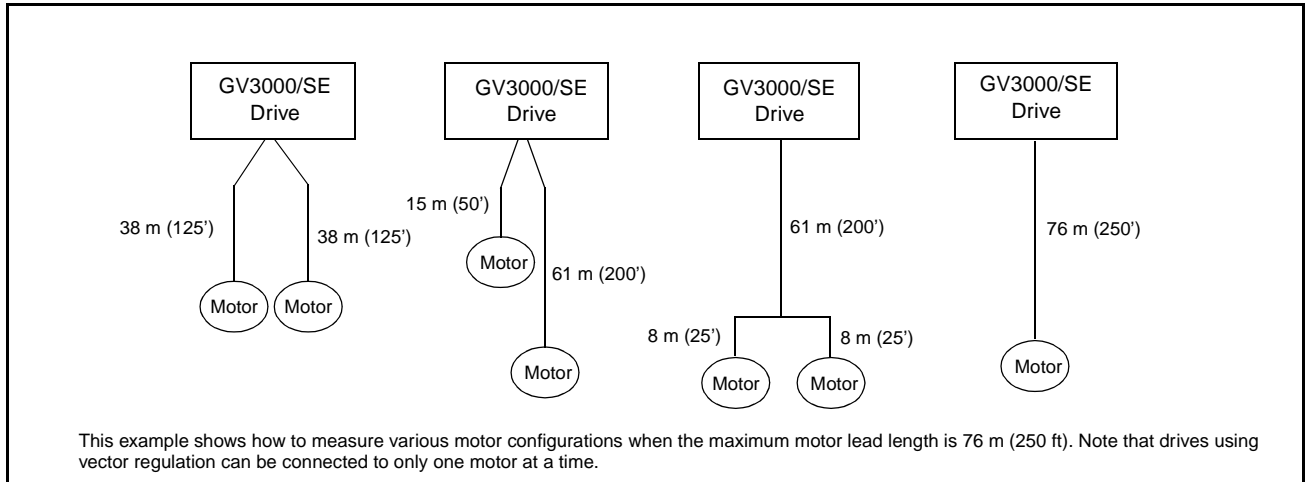

Figure 3.3 – How to Calculate Motor Lead Lengths

Table 3.8 – Recommended Motor Lead Lengths for Reliance Inverter Duty Motors

GV3000/SE Amp Rating	Filter Type	Maximum Lead Length in Feet with 460 VAC Motor		
		Carrier Frequency		
		2 kHz	4 kHz	8 kHz
3.1 to 3.8	None	500	500	500
5.5 to 8.5		500	500	500
12.6 to 15		750	500	500
24 to 43		800	500	500
3.1 to 3.8	A 5% reactor/filter at the drive.	1000	1000	1000
5.5 to 8.5		1000	1000	1000
12.6 to 15		1000	1000	1000
24 to 43		1000	1000	1000

Table 3.9 – Compatible Reactors

GV3000/SE Amp Rating	480 Volt 5% Reactor
3.1	RL-00202
3.8	RL-00403
5.5	RL-00403
8.5	RL-00803
12.6	RL-01203
15	RL-01803
24	RL-02503
30	RL-03503
43	RL-04503

Standard reactors can be used on GV3000/SE drives with carrier frequency settings up to 8 kHz. All reactors listed are UL-recognized (UL-506 File #E53094) and CSA certified (CSA File # LR29753).

### 3.2.2.5 Recommended Serial Communication Cable Lengths

Connector X8 on the Regulator board is an RS-232 serial communication port. See figure 2.6. This connector allows the drive to communicate with external devices such as a personal computer using RS-232 protocol.

Two RS-232 cables are available from Reliance:

- 3 meter (10 feet) D-shell 9-pin to 9-pin cable (M/N 2CA3000)
- 0.3 meter (1 foot) D-shell 9-pin to 25-pin adaptor cable (M/N 2CA3001).

User-constructed cables can be up to 15 meters (50 feet) in length.

Note that for communication between a GV3000/SE drive and a personal computer, the Control and Configuration Software (2CS3000) must also be used. Refer to instruction manual D2-3348 for more information about the CS3000 software.

The Regulator board has one set of RS-232 transmit/receive lines. These lines can be accessed by only **one** device at a time: connector J8 or an Operator Interface Module (OIM).

### 3.2.3 Selecting Input Line Branch Circuit Fuses

	<p><b>ATTENTION:</b> Most codes require that upstream branch circuit protection be provided to protect input power wiring. Install the fuses recommended in table 3.9. Do not exceed the fuse ratings. Failure to observe this precaution could result in damage to, or destruction of, the equipment.</p>
---	--

Input line branch circuit protection fuses must be used to protect the input power lines. See figure 5.1. Recommended fuse values are shown in table 3.10. The input fuse ratings listed in table 3.10 are applicable for one drive per branch circuit. No other load may be applied to that fused circuit.

Table 3.10 – AC Input Fuse Selection Values

U.S. Model Number	European Stock Number	Choke	AC Input Current <sup>1</sup>	External Fuse <sup>2</sup>	
				Nominal	Maximum
31ER40xx	896.01.11	No	5 A	6 A	25 A
31ET40xx	896.01.31	Yes	4 A		
38ER40xx	896.02.11	No	6 A	10 A	25 A
38ET40xx	896.02.31	Yes	5 A		
55ER40xx	896.03.11	No	10 A	16 A	25 A
55ET40xx	896.03.31	Yes	8 A		
85ER40xx	896.05.11	No	13 A	16 A	25 A
85ET40xx	896.05.31	Yes	10 A		
126ER40xx	896.06.11	No	16 A	20 A	25 A
126ET40xx	896.06.31	Yes	13 A		
150ER40xx	896.07.11	No	20 A	25 A	25 A
150ET40xx	896.07.31	Yes	16 A		
240ER40xx	896.08.11	No	31 A	40 A	50 A
240ET40xx	896.08.31	Yes	25 A		

Table 3.10 – AC Input Fuse Selection Values (Continued)

U.S. Model Number	European Stock Number	Choke	AC Input Current <sup>1</sup>	External Fuse <sup>2</sup>	
				Nominal	Maximum
300ER40xx	896.09.11	No	38 A	50 A	50 A
300ET40xx	896.09.31	Yes	32 A		
430ER40xx	896.11.12	No	53 A	63 A	63 A
430ET40xx	896.11.32	Yes	47 A		

<sup>1</sup>AC line input current (RMS) is dependent on total line impedance.

<sup>2</sup>Recommended type of external input fuse:

AC line input: Branch circuit protection fuse, e.g., IEC 269-1/gG, EN 60269-1, VDE 0636/gL, UL Class J, or equivalent.

DC bus input: Semiconductor protection fuse, 660 V or 750 V, superfast, e.g., A70P500, VDE 0636/aR, or equivalent.

### 3.2.4 Meeting Encoder Specifications (FVC Regulation Only)

GV3000/SE drives set up for FVC regulation require an encoder for closed-loop operation. Refer to table A.5 for specifications. Drives set up for V/Hz or SVC regulation do not require an encoder for feedback.

#### 3.2.4.1 Encoder Wiring Guidelines

Encoder connections are considered signal level wiring and, therefore, must be run separate from control and power wiring. Reliance Electric recommends 18 AWG unshielded twisted pair wires with 2-3 twists per inch for applications to a maximum distance of 303 meters (1000 feet). The recommended Reliance Electric part number is 417900-207CG; 18 AWG, 6 conductor (3 twisted pairs).

### 3.2.5 Verifying Power Module Output Current Rating Is Greater Than Motor Full Load Amps

Verify that the GV3000/SE output current rating is greater than the motor's full load current (amps). Table 2.1 lists the output current values.



## Mounting the Drive, Grounding, and Finding Wire Routing Locations

This chapter shows how to mount the drive and properly ground it. Also shown are the entry areas where wiring is to be routed in and out of the drive.

### 4.1 Mounting the Drive

The GV3000/SE Bookshelf drive is provided in an IP20 enclosure and is intended for use inside a larger, user-supplied enclosure.

In order to maintain a flat mounting surface and to ensure that bolt tightness is maintained, use washers under the bolt heads. Use M6 (1/4") mounting bolts and washers.

#### 2 to 30 Amp Drives

Refer to figure 3.1 and table 3.2 in chapter 3 for drive mounting dimensions. Attach the drive to the vertical surface selected using the two (2) mounting brackets provided. The brackets slide into the wide channel of the aluminum heat sink on the back of the drive. Slide one bracket into the top of the channel and the other bracket into the bottom of the channel. Note that the upper mounting bracket is not fixed and, therefore, cannot support the unit alone.

#### 43 Amp Drives

Refer to figure 3.2 and table 3.3 in chapter 3 for drive mounting dimensions. Attach the drive to the vertical surface selected using the built-in mounting brackets.

#### 4.1.1 Verifying the Drive's Watts Loss Rating

When mounting the drive inside of another enclosure, you should determine the watts loss rating of the drive from table 2.1. This table lists the typical full load power loss watts value under all operating carrier frequencies. Ensure that the enclosure is adequately ventilated with 0° to 40°C ambient air based on the drive's watts loss rating.

## 4.2 Determining Input, Motor Output, Ground, and Control Wire Routing for the Drive

All wiring should be installed in conformance with the applicable local, national, and international codes (e.g., NEC/CEC). Signal wiring, control wiring, and power wiring must be routed in separate conduits to prevent interference with drive operation. Note that no wires are to be routed behind the drive. Use grommets, when hubs are not provided, to guard against wire chafing. Figures 4.1, 4.2, and 4.3 show the wire routing, grounding terminal, and power terminal strips of the GV3000/SE Bookshelf drives.



**ATTENTION:** Do not route signal and control wiring with power wiring in the same conduit. This can cause interference with drive operation. Failure to observe this precaution could result in damage to, or destruction of, the equipment.

Do not route more than three sets of motor leads through a single conduit. This will minimize cross-talk that could reduce the effectiveness of noise reduction methods. If more than three drive/motor connections per conduit are required, shielded cable must be used. If possible, each conduit should contain only one set of motor leads.



**ATTENTION:** Unused wires in conduit must be grounded at both ends to avoid a possible shock hazard caused by induced voltages. Also, if a drive sharing a conduit is being serviced or installed, all drives using this conduit should be disabled to eliminate the possible shock hazard from cross-coupled motor leads. Failure to observe these precautions could result in bodily injury.

## 4.3 Grounding the Drive



**ATTENTION:** The user is responsible for conforming with all applicable local, national, and international codes. Failure to observe this precaution could result in damage to, or destruction of, the equipment.

On 2 to 15 A drives, the grounding terminal is located on the drive faceplate (refer to figure 4.1). On 24 to 43 A drives, you will need to remove the drive faceplate and cover to access the grounding terminal (refer to figure 4.2 or 4.3).

Use the following steps to ground the drive:

- Step 1. Run a suitable equipment grounding conductor unbroken from the drive's ground terminal to the motor's ground terminal and then to earth ground. See figures 4.1, 4.2, or 4.3.
- Step 2. Connect a suitable grounding conductor to the motor frame, the remote control station (if used), and the transformer. Run each conductor **unbroken** to earth ground.

When adding more than one grounding conductor wire to a single chassis ground, twist the conductors together.

- Step 3. 24 to 43 A drives only: Reattach the front panel and then the cover.

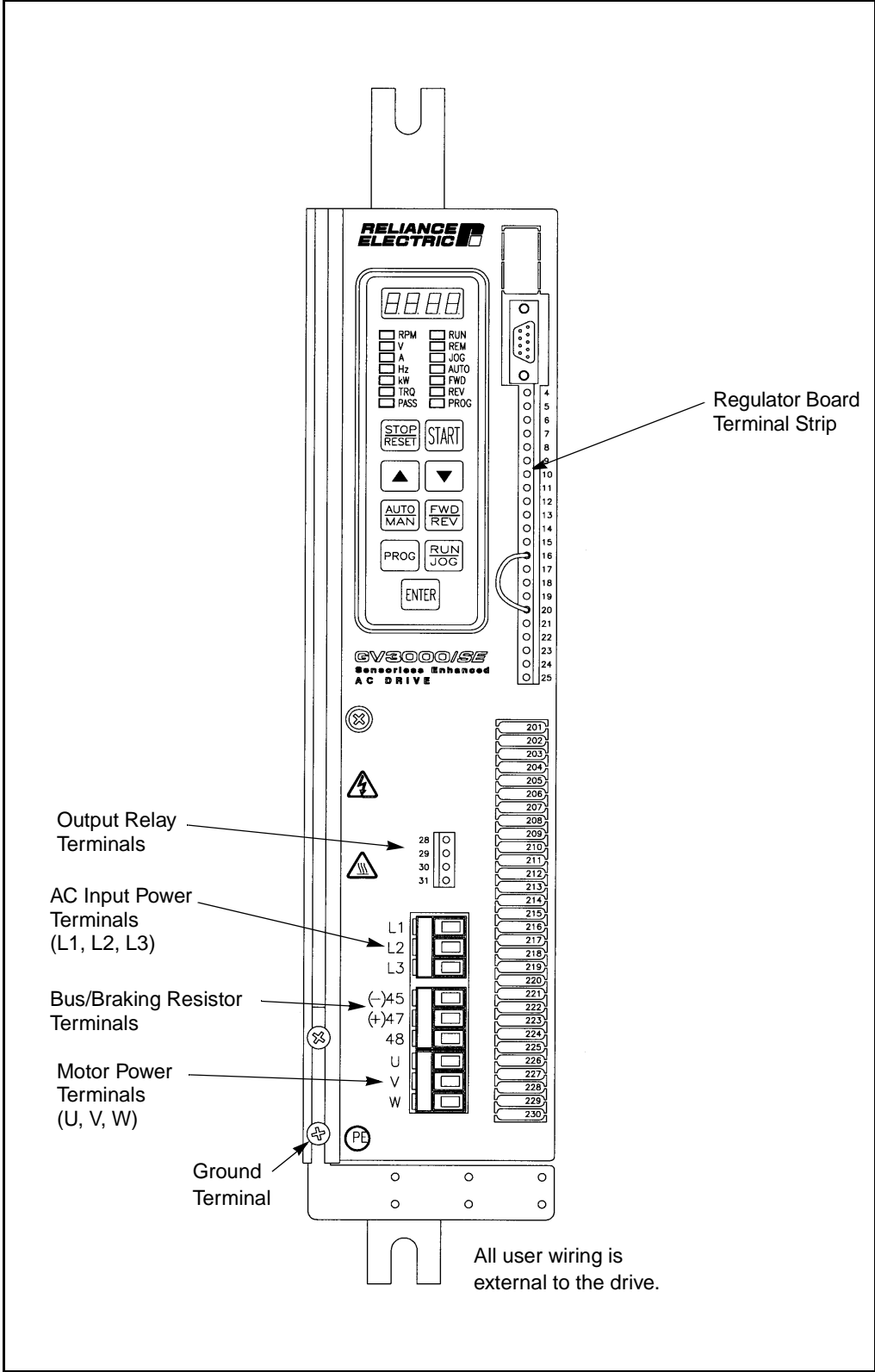

Figure 4.1 – Wire Routing Locations for 2 to 15 Amp Drives

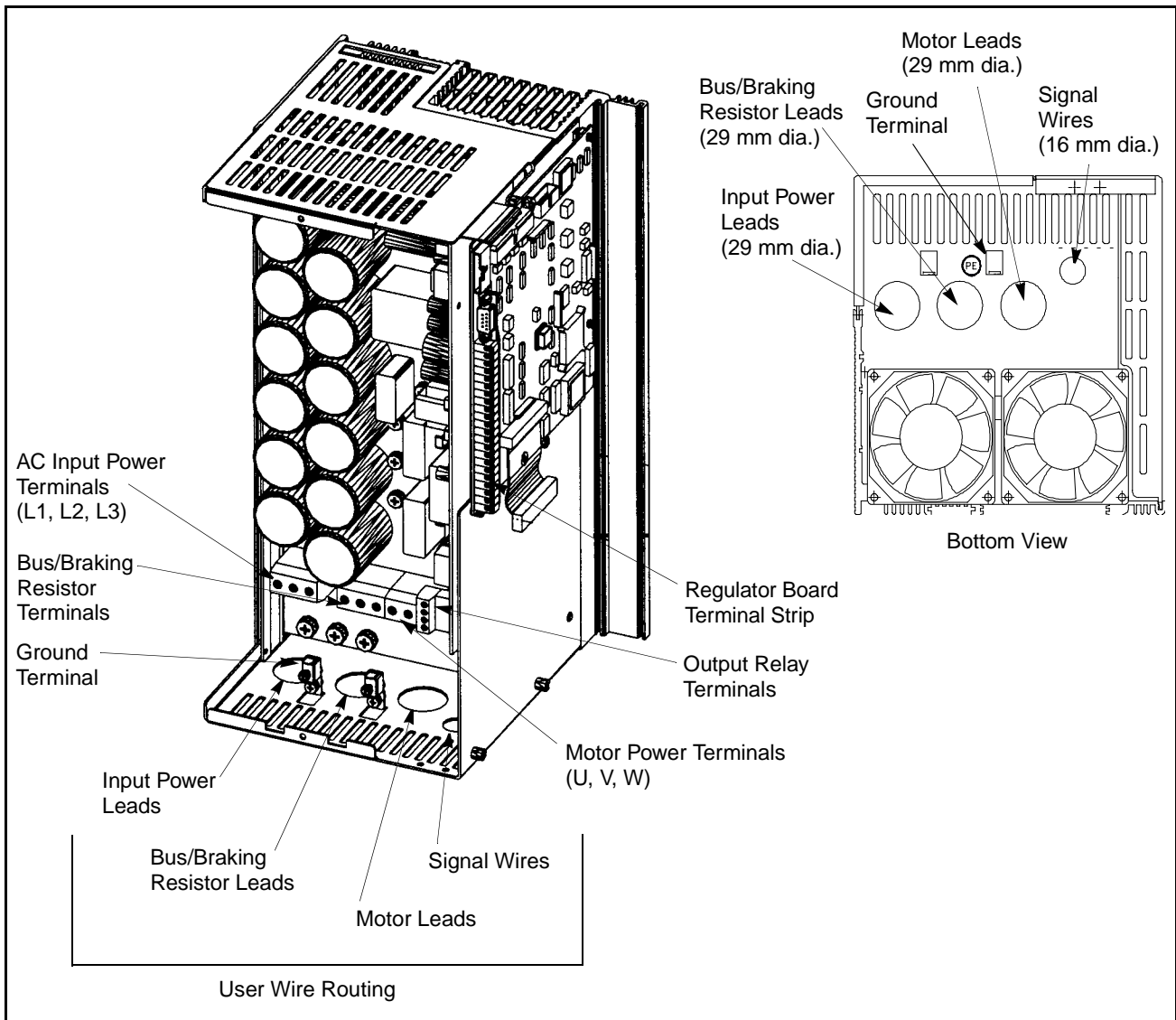

Figure 4.2 – Wire Routing Locations for 24 to 30 Amp Drives

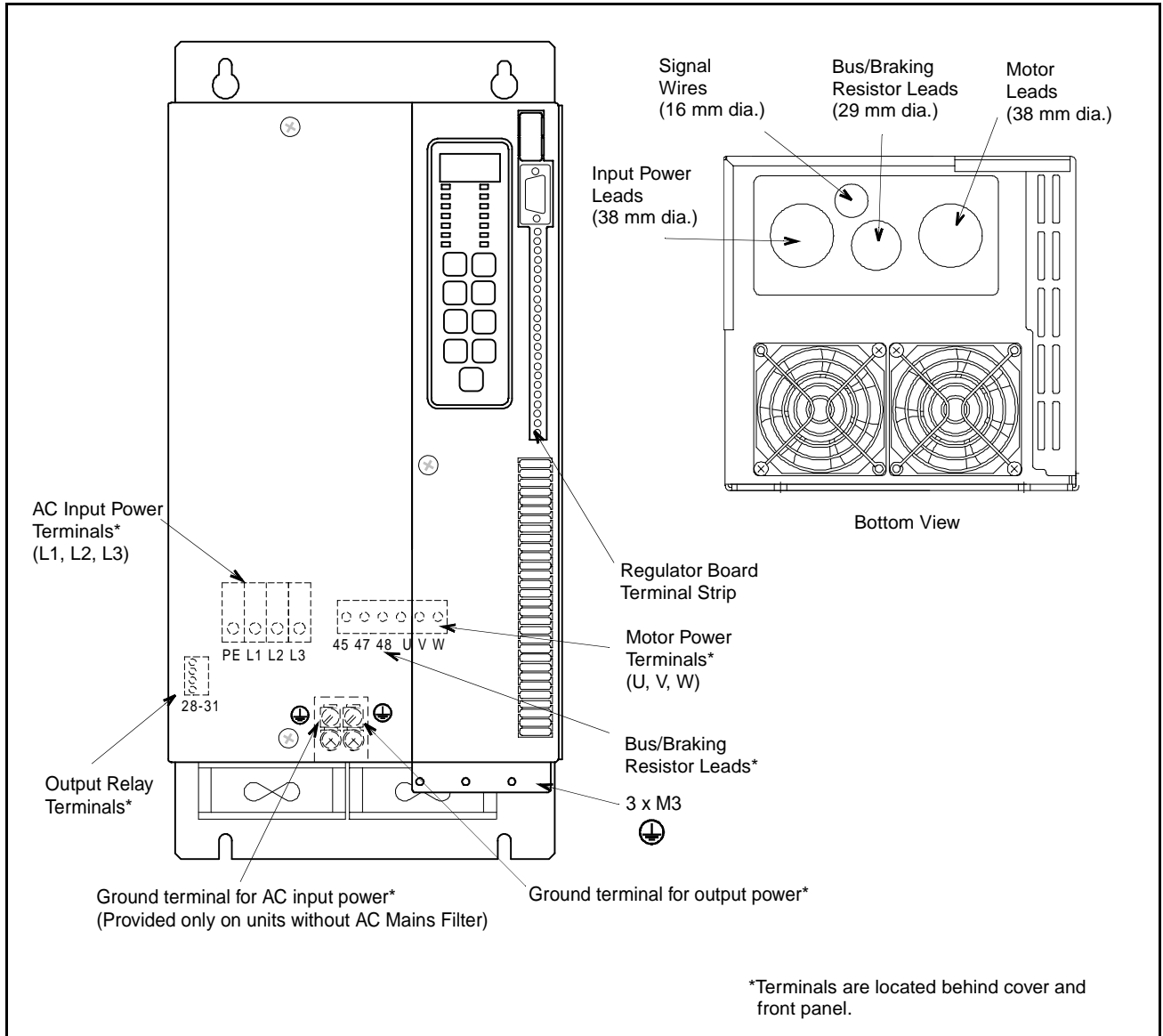

Figure 4.3 – Wire Routing Locations for 43 Amp Drives



## Installing Input Power Wiring

This chapter describes incoming line components and how to install them.

### 5.1 Installing Transformers and Reactors (Optional)

Input isolation transformers might be needed to help eliminate the following:

- Damaging line voltage transients from reaching the drive.
- Line noise from the drive back to the incoming power source.
- Damaging currents that could develop if a point inside the drive becomes grounded.

Observe the following guidelines when installing an isolation transformer:

- A power disconnecting device must be installed between the power line and the primary of the transformer.
- If the power disconnecting device is a circuit breaker, the circuit breaker trip rating must be coordinated with the in-rush current (10 to 12 times full load current) of the transformer.
- For drives equipped with an AC Mains Filter, an input isolation transformer rated more than 1000 KVA for 460 VAC with less than 5% impedance should NOT be used directly ahead of the drive without additional impedance between the drive and the transformer.
- For drives not equipped with an AC Mains Filter, an input isolation transformer rated more than 315 KVA for 460 VAC with less than 5% impedance should NOT be used directly ahead of the drive without additional impedance between the drive and the transformer.



**ATTENTION:** Distribution system capacity above the maximum recommended system KVA (1000 KVA for 460 VAC for drives equipped with an AC Mains Filter, 315 KVA for 460 VAC for drives not equipped with an AC Mains Filter) requires the use of an isolation transformer, a line reactor, or other means of adding similar impedance to the drive power input. Failure to observe these precautions could result in damage to, or destruction of, the equipment.

**ATTENTION:** When the AC line is shared directly with other SCR-rectified drives, an optional snubber resistor braking kit might be required to alleviate excess DC bus voltage. Failure to observe these precautions could result in damage to, or destruction of, the equipment.

For drives equipped with an AC Mains Filter, the maximum AC line distribution system capacity is 1000 KVA, three-phase with 30,000 amps symmetrical fault current capacity with a line impedance of less than 5%.

For drives not equipped with an AC Mains Filter, the maximum line distribution system capacity is 315 KVA, three-phase with 10,000 amps symmetrical fault current capacity with a line impedance of less than 5%.

## 5.2 Installing Fuses for Branch Circuit Protection

Install the required, user-supplied branch circuit protection fuses according to the applicable local, national, and international codes (e.g., NEC/CEC). The fuses must be installed in the line before the drive input terminals. See figure 5.1. Fuse value selections are provided in table 3.10.



**ATTENTION:** Most codes require that upstream branch protection be provided to protect input power wiring. Failure to observe this precaution could result in severe bodily injury or loss of life.

## 5.3 Installing a Required External/Separate Input Disconnect

An input disconnect must be installed in the line before the drive input terminals in accordance with local, national, and international codes (e.g., NEC/CEC). The disconnect should be sized according to the in-rush current as well as any additional loads the disconnect might supply. The trip rating for the inrush current (10-12 times full load current) should be coordinated with that of the input isolation transformer, if used. Refer to section 5.1 for additional information.

## 5.4 Installing Power Wiring from the AC Input Line to the Drive's Power Terminals

Use the following steps to connect AC input power to the drive:

Step 1. Wire the AC input power leads by routing them according to drive type. Refer to figures 4.1, 4.2, or 4.3. Tables 3.5 and 3.6 contain the recommended power wiring sizes.



**ATTENTION:** Do not route signal and control wiring with power wiring in the same conduit. This can cause interference with drive operation. Failure to observe this precaution could result in damage to, or destruction of, the equipment.

Step 2. Connect the three-phase AC input power leads (three-wire 380-460 VAC) to terminals L1, L2, L3.

Step 3. Tighten the AC input power terminals to 1.4 Nm (12 in-lb).

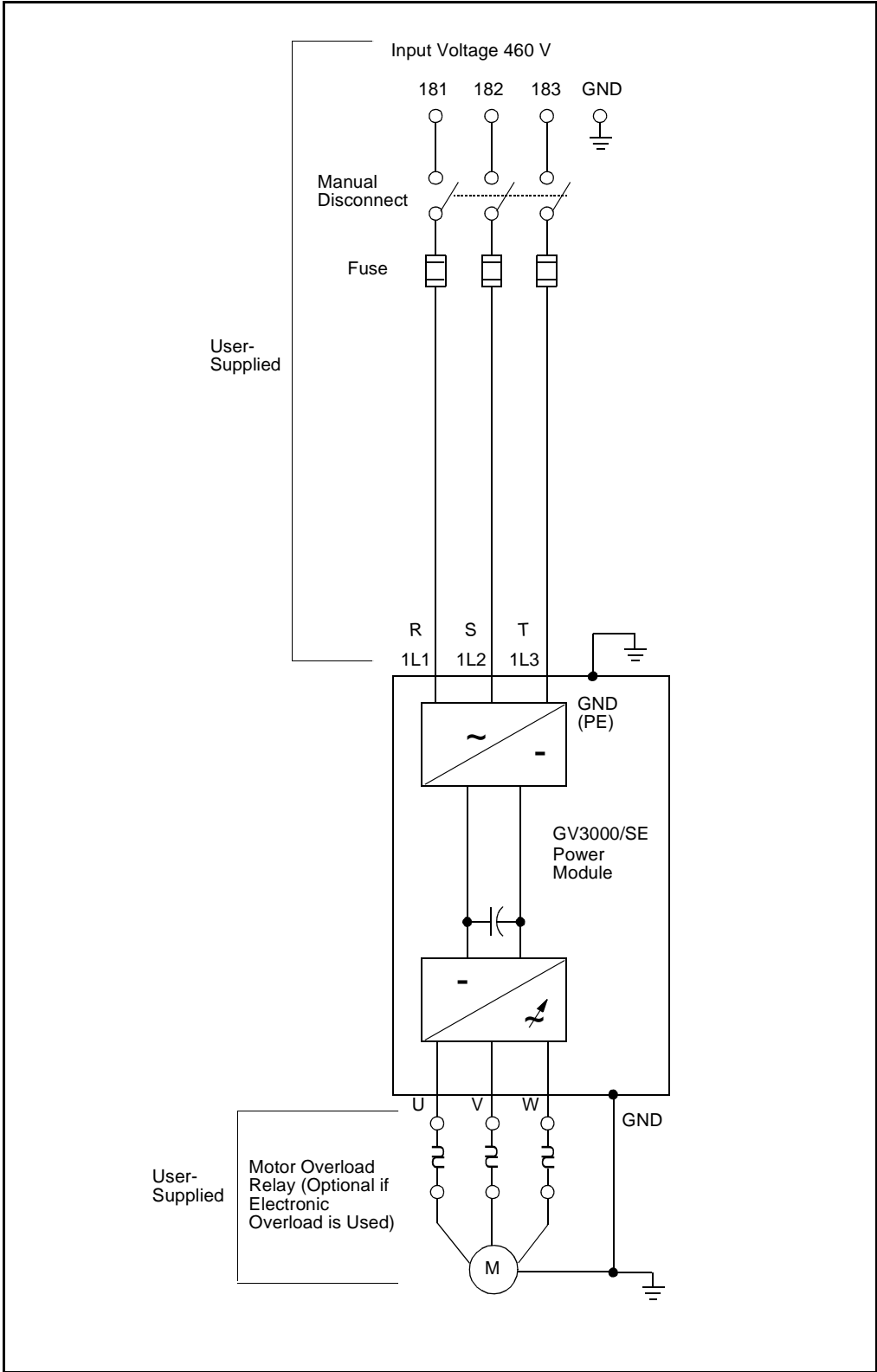

Figure 5.1 – Typical AC Input Electrical Connections



---

## Installing Output Power Wiring

This chapter provides instructions on wiring output contactors, motor overload protection, and output wiring to the motor.

### 6.1 Installing Output Contactors (Optional)

Output contactors provide a positive means of disconnecting the motor from the drive. If the application requires the use of output contactors, contact Reliance Electric for assistance.

### 6.2 Installing Mechanical Motor Overload Protection (Optional)

To provide the motor with overload protection, local, national, and international codes (e.g., NEC/CEC) require one of the following:

- A motor thermostat be installed internal to the motor.
- An electronic thermal motor overload relay, sized to protect the motor, be installed between the motor and the drive's output terminals.

The Motor Overload Enable parameter (P.040) can be used in place of thermal motor overload relays in single motor applications. Note, however, that temperature measuring devices integral to the motor are the best way to thermally protect AC motors under all conditions. Parameter P.040 must be enabled to provide overload protection. Refer to the GV3000/SE Bookshelf Software Start-Up and Reference manual for more information.

In multiple-motor applications (V/Hz regulation only), each motor must have its own user-supplied overload protection.

### 6.3 Installing Output Wiring from the Drive Output Terminals to the Motor

Use the following steps to connect the AC output power wiring from the drive to the motor:

- Step 1. Wire the three-phase AC output power motor leads by routing them according to drive type. Refer to figures 4.1, 4.2, or 4.3. Tables 3.5 and 3.6 contain the recommended power wiring sizes.

Do not route more than three sets of motor leads through a single conduit. This will minimize cross-talk that could reduce the effectiveness of noise reduction methods. If more than three drive/motor connections per conduit are required, shielded cable must be used. If possible, each conduit should contain only one set of motor leads.



**ATTENTION:** Do not route signal and control wiring with power wiring in the same conduit. This can cause interference with drive operation. Failure to observe these precautions could result in damage to, or destruction of, the equipment

**ATTENTION:** Unused wires in conduit must be grounded at both ends to avoid a possible shock hazard caused by induced voltages. Also, if a drive sharing a conduit is being serviced or installed, all drives using this conduit should be disabled to eliminate the possible shock hazard from cross-coupled motor leads. Failure to observe these precautions could result in bodily injury.

- Step 2. Connect the three-phase AC output power motor leads to terminals U, V, and W.
- Step 3. Tighten the three-phase AC output power terminals to 1.4 Nm (12 in-lb).

## Wiring the Regulator Board Terminal Strip and the Output Relay Terminal Strip

This chapter describes how to wire the Regulator board terminal strip for stop, encoder feedback, and remote control signals. It also describes how to wire the output status relays on the output relay terminal strip.

The signals available through the Regulator board terminal strip are shown in tables 7.1 to 7.4 and figures 7.1 and 7.2. Table 7.6 provides additional information.

Note that when the Control Source parameter (P.000) is set to remote (rE), the drive will be controlled by the signals connected to the terminal strip. Refer to the GV3000/SE Bookshelf Drive Software Start-Up and Reference manual for more information on how parameter P.000 is used to specify where the drive is controlled from.

The signals available through the output relay terminal strip are shown in table 7.5. Table 7.7 provides additional information.

Table 7.1 – Encoder Connections (Regulator Terminals 4-9)

Terminal #	Signal
4	+15 VDC
5	Phase A
6	Phase A Not
7	Phase B
8	Phase B Not
9	Regulator Common
<b>Notes:</b> An encoder feedback device must be installed if FVC regulation is used.	

Table 7.2 – Analog Output Connections (Regulator Terminals 10 and 11)

Terminal #	Signal
10	Analog Meter Output
11	Analog Output Return
<b>Notes:</b> The output of this terminal is either 0-10 VDC or 4-20 mA as determined by the setting of jumper J17 on the Regulator board. The analog output must also be programmed via parameter P.012 for an indication of speed and direction or percent of torque.	

Table 7.3 – Analog Speed/Torque Reference Connections (Regulator Terminals 12-15)

Terminal #	Signal
12	Isolated Reference Voltage
13	VDC Speed/Torque Reference
14	mA Speed/Torque Reference
15	Isolated Reference Common

**Notes:** The analog speed/torque (P.008/U.000) reference is either +/-10 VDC or +/-20 mA, as determined by the setting of jumper J4 on the Regulator board. The analog reference can be adjusted using parameters P.009, P.010, and P.011.

Refer to Appendix G in the GV3000/SE Bookshelf Drive Software Start-Up and Reference manual for more information about the analog input.

Table 7.4 – Digital Input Connections (Regulator Terminals 16-25)

Terminal #	Signal
16	+24 VDC (Current Limited) (For remote control digital inputs only)
17	Digital Input 8 (Remote/Local) - Programmable
18	Digital Input 7 (Ramp 1/Ramp 2) - Programmable
19	Digital Input 6 (Forward/Reverse) - Programmable
20	Function Loss
21	Run/Jog
22	Reset
23	Stop
24	Start
25	+24 VDC Common

**Notes:** When a user-installed function loss input, a coast-to-stop pushbutton, or another external interlock is installed, the factory-installed jumper connecting terminals 16 and 20 must be removed so that a contact, when open, will stop the drive.

Terminals 17, 18, and 19 (remote control inputs 8, 7, and 6) are programmed using parameters P.007, P.008, and P.031 through P.038. Factory default settings are shown here in parentheses. Refer to the GV3000/SE Bookshelf Drive Software Start-Up and Reference manual for more information.

Table 7.5 – Status Relay Connections (Relay Terminals 28-31) on the Output Relay Terminal Strip

Terminal #	Signal
28	N.C Relay Contact
29	N.C. Relay Common
30	N.O. Relay Contact
31	N.O. Relay Common

**Notes:** Relay contact closure is programmable through parameter P.013. Refer to the GV3000/SE Bookshelf Drive Software Start-Up and Reference manual for more information.

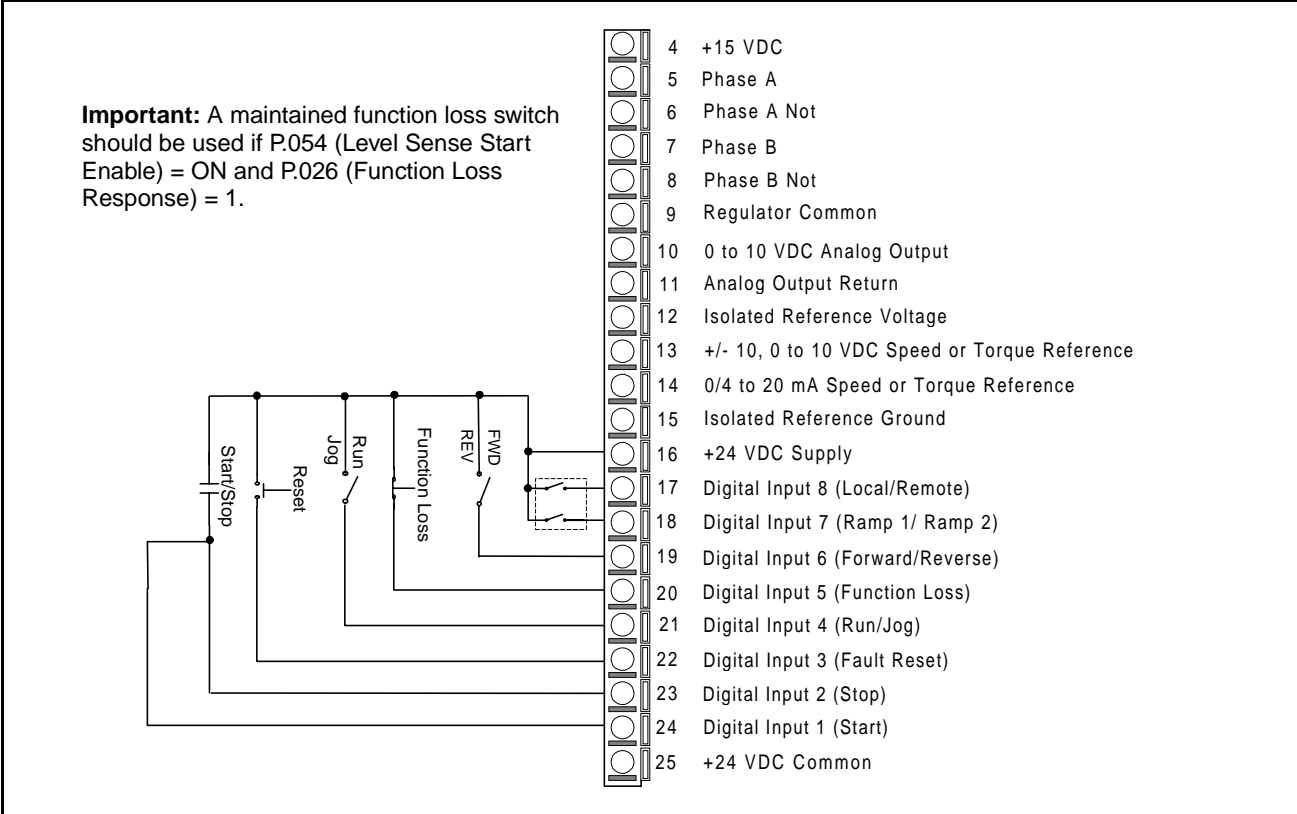

Figure 7.1 – Two-Wire Start/Stop Sample Control Wiring

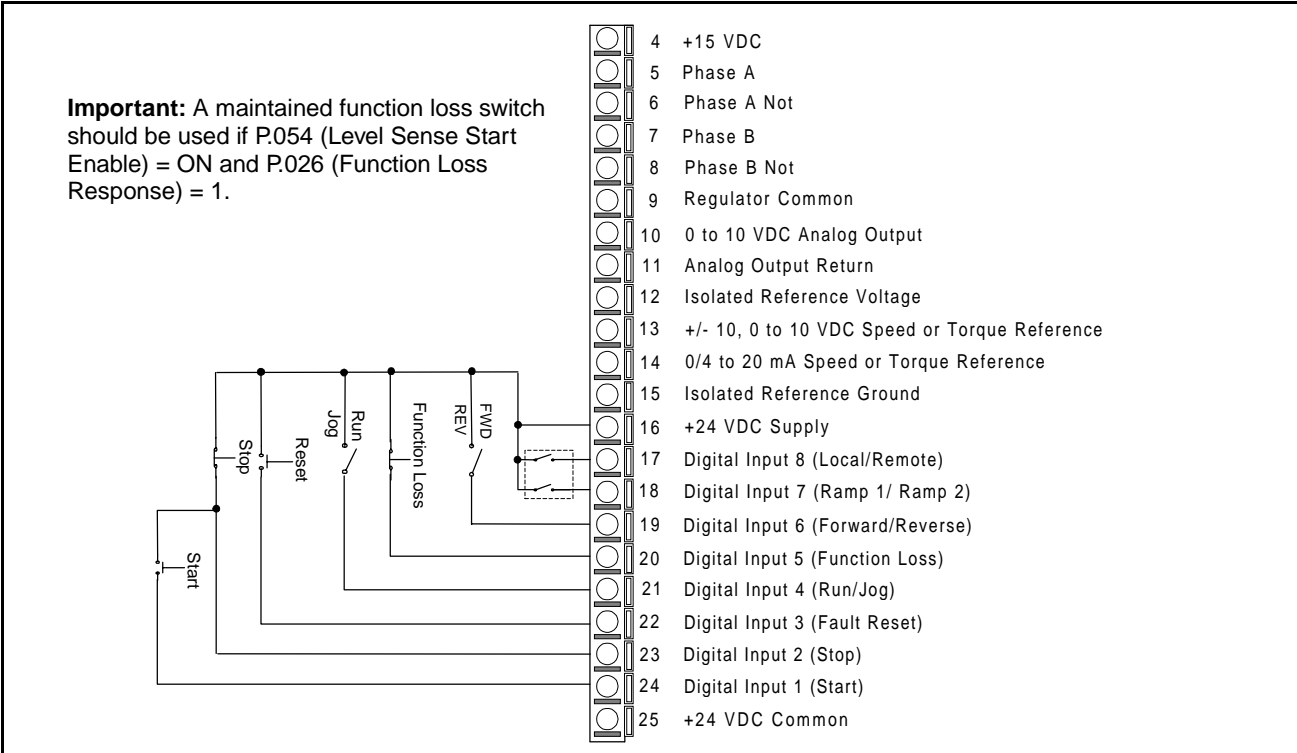

Figure 7.2 – Three-Wire Start/Stop Sample Control Wiring

## 7.1 Stopping the Drive



**ATTENTION:** When P.055 is set to ON, the STOP/RESET key is functional only from the selected control source. As a safety precaution, Reliance Electric recommends that an emergency stop push button be located near the drive in an easily accessible location. As a further safety precaution, the user should post a warning on the drive to alert personnel that the STOP/RESET key is not functional. Failure to observe this precaution could result in severe bodily injury or loss of life.

**ATTENTION:** The user must provide an external, hardwired emergency stop circuit outside of the drive circuitry. This circuit must disable the system in case of improper operation. Uncontrolled machine operation may result if this procedure is not followed. Failure to observe this precaution could result in bodily injury.

Depending upon the requirements of the application, the GV3000/SE Bookshelf drive can be programmed to provide either a coast-to-rest or a ramp-to-rest operational stop without physical separation of the power source from the motor.

A coast-to-rest stop turns off the transistor power device drivers. A ramp-to-rest stop fires the transistor power device drivers until the motor comes to a stop, and then turns off the power devices.

The user can also program zero speed with power maintained to the motor, but in this condition, the drive is not actually stopped.

See the description of terminals 23 and 24 or Stop Type (P.025) for more information on how to program the operational stop.

In addition to the operational stop, the user must provide a hardwired emergency stop external to the drive. The emergency stop circuit must contain only hardwired electromechanical components. Operation of the emergency stop must not depend on electronic logic (hardware or software) or on the communication of commands over an electronic network or link.

Parameter P.055 (STOP/RESET Key Disable) can be used to change the operation of the STOP/RESET key. See the P.055 parameter description in the software manual for more information.

Note that the user-installed hardwired emergency stop may be used at any time to stop the drive.

### 7.1.1 Compliance with Machinery Safety Standard EN 60204-1:1992

This section applies to users who must comply with machinery safety standard EN 60204-1:1992, part 9.2.5.4, Emergency Stop.

The GV3000/SE drive coast-to-rest stop is a category 0 operational stop. The ramp-to-rest stop is a category 1 operational stop. In addition, it is possible to implement a category 2 stop, with power maintained to the motor at zero speed.

The required external hardwired emergency stop must be either a category 0 or 1 stop, depending on the user's risk assessment of the associated machinery. In order to fully comply with machinery safety standard EN60204-1:1992, part 9.2.5.4, at least one of the two stop methods must be a category 0 stop. Refer to Appendix B for more information.

## 7.2 Wiring the Encoder Feedback Device (FVC Regulation Only)

If the GV3000/SE drive is programmed to provide FVC regulation, an encoder must be installed on the motor. Drives using V/Hz or SVC regulation do not require the use of an encoder feedback device. The encoder connects to terminals 4 through 9 of the Regulator board terminal strip as shown in table 7.6:

Table 7.6 – Encoder Connections

Terminal	Encoder Connection
4	Encoder Supply +15 VDC (250 mA capacity)
5	Encoder Phase A Differential Input
6	Encoder Phase A Not Differential Input
7	Encoder Phase B Differential Input
8	Encoder Phase B Not Differential Input
9	Encoder/Regulator Common

Use the following procedure to connect an encoder to the Regulator board terminal strip:

Step 1. Connect the encoder's wires to terminals 4 through 9 of the terminal strip. See figure 7.3. Refer to section 3.2.4.1 for encoder wiring guidelines.

Step 2. Set the following parameters to establish the maximum motor speed:

- P.004: Maximum Speed
- U.001: Encoder PPR
- U.002: Motor Poles
- U.003: Motor Nameplate Base Frequency
- U.005: Motor Nameplate RPM
- U.017: Motor Top Speed

Refer to the GV3000/SE Bookshelf Drive Software Start-Up and Reference manual for parameter descriptions.

Tamagawa-Style, 16-Pin MS Connector  
View of Encoder Cable MS Connector (Female)  
(M/N 2TC4025 and 2TC4075)

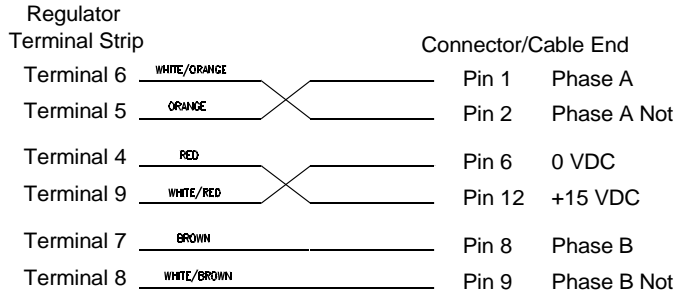
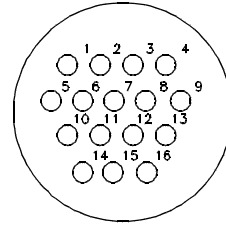

Dynapar-Style, 10-Pin MS Connector  
View of Encoder Cable MS Connector (Female)  
(M/N 2TC3025 and 2TC3075)

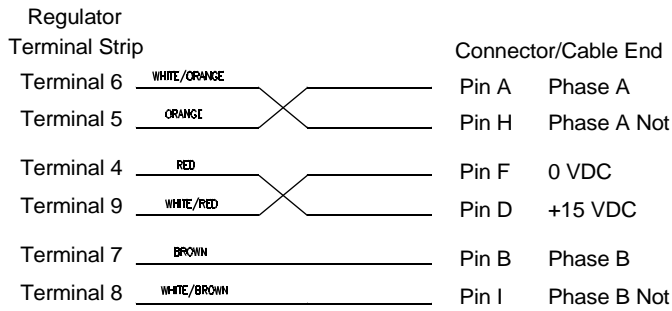
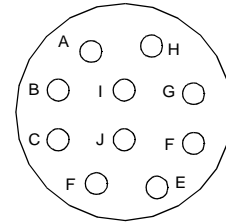

Lakeshore-Style, 10-Pin MS Connector  
View of Encoder Cable MS Connector (Female)  
(Lakeshore M/N SL56 Slim-Tach Encoder)

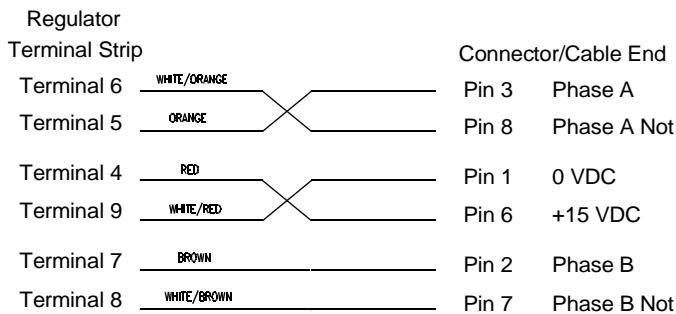
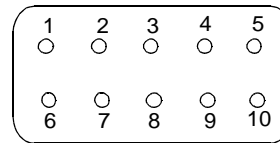

Figure 7.3 – Encoder Wiring Connections

## 7.3 Wiring the Signal and Control I/O

Wire the drive's signal and control I/O to the terminal strip as shown in figure 7.4 and table 7.7.

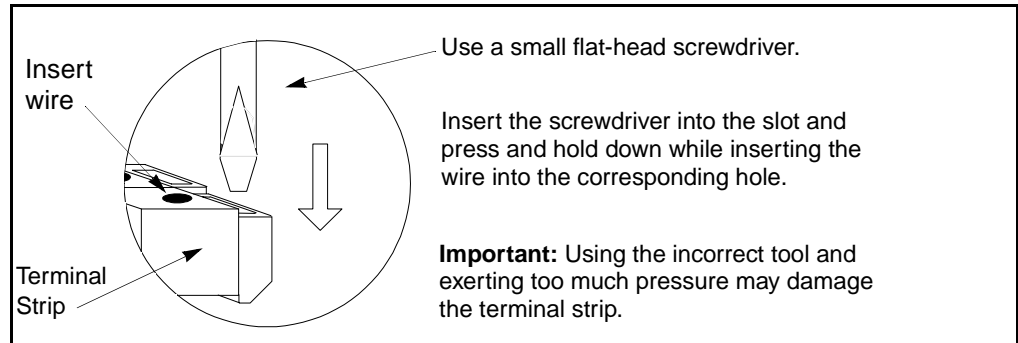

Figure 7.4 – Wiring the Terminal Strip - Detail

Table 7.7 – Wiring Signal and Control I/O to the Regulator Board Terminal Strip

Terminal Number	Description	Parameters/Wiring Connections
<b>Wiring Encoder Inputs</b>		
4-9	Encoder Wiring	See section 7.2.
<b>Wiring Analog Outputs</b>		
10	0-10 VDC or 4-20 mA Analog Output Reference	<p>The setting of parameter P.012 selects the terminal strip analog output source (either speed or torque). Jumper J17 must also be set. See figure 2.8.</p> <p>The 4-20 mA current selection requires a power supply for operation. The power must be sourced from an external 12 V power supply.</p> <p>Terminals 9 and 11 are internally connected.</p>
11	Analog Output Return	

Table 7.6 - Wiring Signal and Control I/O to the Regulator Board Terminal Strip (Continued)

Terminal Number	Description	Parameters/Wiring Connections
<b>Wiring Analog Speed Reference Inputs</b>		
12	Isolated Reference Voltage (+10 VDC)	Related parameters: <ul style="list-style-type: none"> <li>• P.000: Control Source</li> <li>• P.009: Terminal Strip Analog Input Offset</li> <li>• P.010: Terminal Strip Analog Input Gain</li> <li>• P.011: Terminal Strip Analog Input Configure</li> </ul> Refer to the GV3000/SE Bookshelf Drive Software Start-Up and Reference manual for additional parameter information. Jumper J4 must also be set. See figure 2.7.
13	Analog Speed/Torque Reference Input Voltage (+/- 10 VDC)	
14	Analog Speed/Torque Reference Input Current (0-20 mA)	
15	Isolated Speed/Torque Reference Common (Voltage/Current)	
		 <p style="text-align: center;">INPUT SPEED REFERENCE</p> <p>Refer to Appendix G of the GV3000/SE Bookshelf Drive Software Start-Up and Reference manual for more information about the analog input.</p>

Table 7.6 - Wiring Signal and Control I/O to the Regulator Board Terminal Strip (Continued)

Terminal Number	Description	Parameters/Wiring Connections
<b>Wiring a Remote/Local Input</b>		
16	+24 VDC Power Supply	Current limited for remote input logic use only.
17	Digital Input 8 (Default - Remote/Local)	Digital input 8 is control function programmable through parameter P.007.
	<p><b>ATTENTION:</b> If a maintained start contact is used when the control source = rE, switching from local to remote from the terminal strip will cause power to be applied to the motor if the remote start contact is closed. Stay clear of rotating machinery in this case. Failure to observe this precaution could result in bodily injury.</p>	
		<p>The following parameters must be set:</p> <ul style="list-style-type: none"> <li>• P.000: Control Source (Only active when P.000 = rE)</li> <li>• P.006: Second Menu Password</li> <li>• P.007: Terminal Strip Digital Inputs Configure (Selects and assigns a control function to digital inputs 6 to 8)</li> <li>• P.008: Terminal Strip Speed Reference Source (Analog, Motor Operated Potentiometer (MOP), or Preset Speeds)</li> </ul> <p>Note that based on the settings of parameters P.000, P.007, P.008, and r.030 if an RMI board is used, the following parameters can affect digital input 8:</p> <ul style="list-style-type: none"> <li>• P.023: MOP Accel/Decel Time</li> <li>• P.024: MOP Reset Configuration</li> <li>• P.031 to P.038: Preset Speeds 1-8</li> </ul> <p>Refer to the GV3000/SE Bookshelf Drive Software Start-Up and Reference manual for additional information.</p> <div style="text-align: center;">  </div> <p>Terminal 17 On = Local Control Diagram shows factory setting.</p>

Table 7.6 - Wiring Signal and Control I/O to the Regulator Board Terminal Strip (Continued)

Terminal Number	Description	Parameters/Wiring Connections
<b>Wiring an Additional Ramp Input</b>		
18	Digital Input 7 (Default - Ramp 1/Ramp 2)	<p>Digital input 7 is control function programmable through parameter P.007. The following parameters must be set:</p> <ul style="list-style-type: none"> <li>• P.000: Control Source</li> <li>• P.001: Accel Time 1 (Ramp 1)</li> <li>• P.002: Decel Time 1 (Ramp 1)</li> <li>• P.006: Second Menu Password</li> <li>• P.007: Terminal Strip Digital Inputs Configure (Selects and assigns a control function to digital inputs 6 to 8)</li> <li>• P.008: Terminal Strip Speed Reference Source (Analog Motor Operated Potentiometer (MOP), or Preset Speeds)</li> <li>• P.017: Accel Time 2 (Ramp 2)</li> <li>• P.018: Decel Time 2 (Ramp 2)</li> </ul> <p>Note that based on the settings of parameters P.000, P.007, P.008, and r.030 if an RMI board is used, the following parameters can affect digital input 7:</p> <ul style="list-style-type: none"> <li>• P.023: MOP Accel/Decel Time</li> <li>• P.024: MOP Reset Configuration</li> <li>• P.031 to P.038: Preset Speeds 1-8</li> </ul> <p>Refer to the GV3000/SE Bookshelf Drive Software Start-Up and Reference manual for additional information.</p> <div data-bbox="829 1083 1206 1283" style="text-align: center;"> </div> <p>Terminal 18 On = Ramp 2 Diagram shows factory setting.</p>

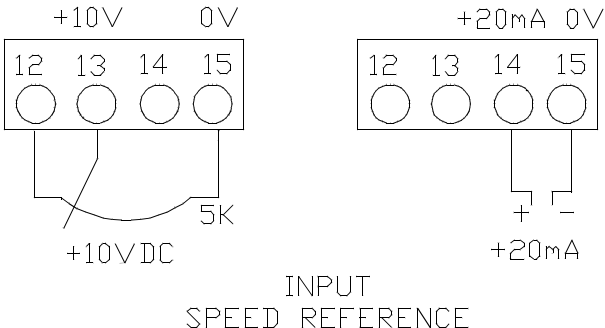
Table 7.6 - Wiring Signal and Control I/O to the Regulator Board Terminal Strip (Continued)

Terminal Number	Description	Parameters/Wiring Connections
<b>Wiring a Forward/Reverse Input</b>		
19	Digital Input 6 (Default - Forward/Reverse)	<p>Digital input 6 is control function programmable through parameter P.007. The following parameters must be set:</p> <ul style="list-style-type: none"> <li>• P.000: Control Source</li> <li>• P.006: Second Menu Password</li> <li>• P.007: Terminal Strip Digital Inputs Configure (Selects and assigns a control function to digital inputs 6 to 8)</li> <li>• P.008: Terminal Strip Speed Reference Source (Analog, Motor Operated Potentiometer (MOP), or Preset Speeds)</li> <li>• P.027: Forward/Reverse Configuration</li> </ul> <p>Note that based on the settings of parameters P.000, P.007, P.008, and r.030 if an RMI board is used, the following parameters can affect digital input 6:</p> <ul style="list-style-type: none"> <li>• P.023: MOP Accel/Decel Time</li> <li>• P.024: MOP Reset Configuration</li> <li>• P.031 to P.038: Preset Speeds 1-8</li> </ul> <p>Refer to the GV3000/SE Bookshelf Drive Software Start-Up and Reference manual for additional information.</p> <div data-bbox="873 982 1252 1184" style="border: 1px solid black; padding: 5px; margin: 10px auto; width: fit-content;">  <p style="text-align: center;">If P.027 = 1 Forward Direction Only</p> </div> <p>Terminal 19 On = Reverse Direction</p> <p>Diagram shows factory setting. From the encoder end of the motor, clockwise rotation indicates forward motor movement.</p>

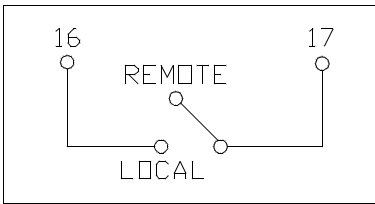
Table 7.6 - Wiring Signal and Control I/O to the Regulator Board Terminal Strip (Continued)

Terminal Number	Description	Parameters/Wiring Connections
<b>Wiring a Function Loss Input</b>		
20	Digital Input 5 (Function Loss)	<p>The following parameters must be set:</p> <ul style="list-style-type: none"> <li>• P.026: Function Loss Response</li> </ul> <p>A signal must be present at terminal 20 for the drive to be able to start. See figures 7.1 and 7.2.</p> <p>The drive is shipped from the factory with a jumper between terminals 16 and 20 which provides the signal. The function loss input should be in series with the drive's external interlocks. In this case, the jumper must be removed before the connections are made.</p> <div data-bbox="711 674 1318 1016" style="border: 1px solid black; padding: 10px; text-align: center;"> <p>TERMINAL STRIP</p> <p>REMOVE FACTORY FUNCTION LOSS JUMPER HERE</p> <p>FUNCTION LOSS COAST-STOP PUSHBUTTON</p> <p>SAFETY INTERLOCKS</p> </div> <p>Terminal 20 On = No Function Loss</p> <p><b>Important:</b> A maintained function loss switch should be used if P.054 (Level Sense Start Enable) = ON and P.026 (Function Loss Response) = 1.</p>
<b>Wiring a Run/Jog Input</b>		
21	Digital Input 4 (Run/Jog)	<p>The following parameters must be set:</p> <ul style="list-style-type: none"> <li>• P.000: Control Source</li> <li>• P.020: Jog Speed Reference</li> <li>• P.021: Jog Ramp Accel Time</li> <li>• P.022: Jog Ramp Decel Time</li> </ul> <div data-bbox="829 1488 1208 1705" style="border: 1px solid black; padding: 10px; text-align: center;"> </div> <p>Terminal 21 On = Jog Operation</p>

Table 7.6 - Wiring Signal and Control I/O to the Regulator Board Terminal Strip (Continued)

Terminal Number	Description	Parameters/Wiring Connections
<b>Wiring the Reset Input</b>		
22	Digital Input 3 (Reset)	<p>The following parameter must be set:</p> <ul style="list-style-type: none"> <li>• P.000: Control Source</li> </ul> <div data-bbox="875 436 1258 625" style="text-align: center;"> </div> <p>Terminal 22 On = Reset</p>
<b>Wiring the Stop/Start Inputs</b>		
23  24	Digital Input 2 (Stop)  Digital Input 1 (Start)	<p>The following parameter must be set:</p> <ul style="list-style-type: none"> <li>• P.000: Control Source</li> <li>• P.025: Stop Type</li> </ul> <div data-bbox="755 877 1378 1050" style="text-align: center;"> </div> <p>Terminal 23 Off = Stop Terminal 24 On Transition = Start</p>
25	24 VDC Isolated Common	

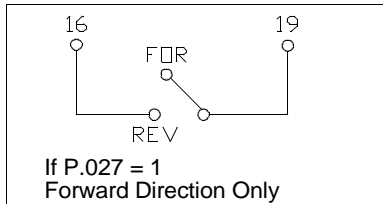
Table 7.8 – Wiring the Output Relay Terminal Strip

Terminal Number	Description	Parameters/Wiring Connections
<b>Wiring the Output Status Relays</b>		
28	Normally-Closed Contact (Form B)	<p>Both Form A and Form B contacts are rated for 250 VAC/30 VDC at 5 amps resistive or 2 amps inductive load.</p> <p>The following parameter must be set:</p> <ul style="list-style-type: none"> <li>• P.013: Output Relay Configuration</li> </ul> <p>Note that depending on the setting of parameter P.013, the relay coil will energize (the normally-open contact will close and the normally-closed contact will open). Refer to the GV3000/SE Bookshelf Drive Software Start-Up and Reference manual for more information.</p> <div data-bbox="829 737 1208 1094" style="text-align: center;"> <p>PARAMETER P.013 SELECTS OUTPUT INDICATION</p> </div>
29	Normally-Closed Contact Common (Form B)	
30	Normally-Open Contact (Form A)	
31	Normally-Open Contact Common (Form A)	

## Wiring Optional User-Supplied Braking Resistors

This chapter describes how to select and wire optional user-supplied braking resistors.



**ATTENTION:** The user is responsible for conforming with all applicable local, national, and international codes. Failure to observe this precaution could result in damage to, or destruction of, the equipment.

### 8.1 Installation Guidelines

Use the following guidelines when installing braking resistors:

- The cable length of the connection between the braking unit and the resistor must not exceed 2.5 m (8 ft).
- Provide ground connections as shown in figure 8.1.
- The conductors should be twisted together and run separate from other conductors.
- If the braking resistor is mounted in a separate enclosure, this must be metallic conductive and the diameter of ventilation holes should not exceed 6 mm (.236 in).
- Heat-resistant cables and cable sockets (minimum 90° C) must be used to connect the braking resistor.
- Wire rated at a minimum of least 600 volts for 460 VAC must be used. Refer to table 8.1 for cable cross-section specifications.



**ATTENTION:** It is important to use wire rated at 600 volts for 460 VAC because this wiring may make contact with uninsulated 460 VAC components. Failure to observe this precaution could result in damage to, or destruction of, the equipment.

- If the drive installation must be in compliance with the European community electromagnetic compatibility standards, refer to Appendix C.

Table 8.1 – Cable Cross-Sections for External Braking Resistors

<b>Drive M/N</b>	<b>Maximum Continuous Braking Current (A rms)</b>	<b>Minimum Cable Cross-Section</b>
31ER40xx 31ET40xx	6	1 mm <sup>2</sup> (16 AWG)
38ER40xx 38ET40xx	6	1 mm <sup>2</sup> (16 AWG)
55ER40xx 55ET40xx	6	1 mm <sup>2</sup> (16 AWG)
85ER40xx 85ET40xx	6	1 mm <sup>2</sup> (16 AWG)
126ER40xx 126ET40xx	10	1 mm <sup>2</sup> (16 AWG)
150ER40xx 150ET40xx	10	1 mm <sup>2</sup> (16 AWG)
240ER40xx 240ET40xx	15	1.5 mm <sup>2</sup> (16 AWG)
300ER40xx 300ET40xx	20	2.5 mm <sup>2</sup> (12 AWG)
430ER40xx 430ET40xx	30	6 mm <sup>2</sup> (12 AWG)

## 8.2 Selecting a Braking Resistor

The maximum braking power is defined by the maximum braking current and the maximum DC voltage (750 V). To determine the correct braking resistor for your drive, refer to table 8.2.

Table 8.2 – Selecting a Braking Resistor

Drive M/N	Braking Power <sup>1</sup>		Maximum Braking Current	Power Module Input Voltage	Turn-On Voltage	Turn-Off Voltage	Minimum Allowed External Braking Resistor
	Continuous	25% Duty Cycle					
31ER40xx 31ET40xx	4.5 kW	4.5 kW	6 A	460 V	750 V	720 V	125.0 Ω
38ER40xx 38ET40xx	4.5 kW	4.5 kW	6 A	460 V	750 V	720 V	125.0 Ω
55ER40xx 55ET40xx	4.5 kW	4.5 kW	6 A	460 V	750 V	720 V	125.0 Ω
85ER40xx 85ET40xx	4.5 kW	4.5 kW	6 A	460 V	750 V	720 V	125.0 Ω
126ER40xx 126ET40xx	7.5 kW	7.5 kW	10 A	460 V	750 V	720 V	75.0 Ω
150ER40xx 150ET40xx	7.5 kW	7.5 kW	10 A	460 V	750 V	720 V	75.0 Ω
240ER40xx 240ET40xx	11 kW	11 kW	15 A	460 V	750 V	720 V	50.0 Ω
300ER40xx 300ET40xx	15 kW	15 kW	20 A	460 V	750 V	720 V	37.5 Ω
430ER40xx 430ET40xx	22 kW	22 kW	30 A	460 V	750 V	720 V	25.0 Ω

<sup>1</sup>The turn-on and the turn-off voltage and the braking power is proportional to the AC line voltage (specified in parameter H.021 or U.018).

## 8.3 Installing the Braking Resistor

To prevent possible damage due to an overload on the braking resistors, install a thermal protection device according to figure 8.1 and table 8.3.

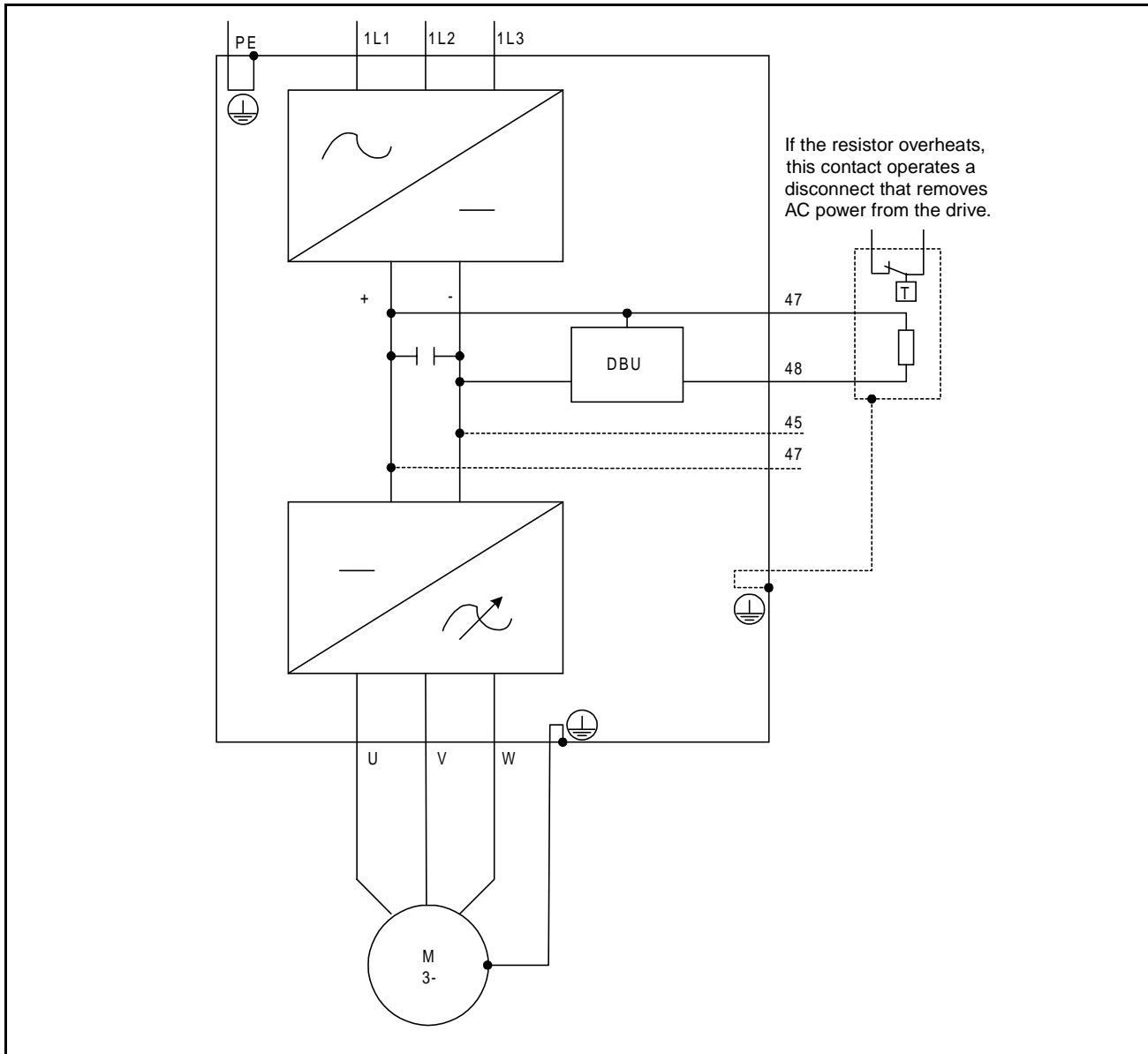

Figure 8.1 – Braking Resistor Wiring Connections

Table 8.3 – Wiring Connections for External Braking Resistor

Terminal	Description
47	External Braking Resistor
48	
⊕	Ground

## Completing the Installation

This chapter provides instructions on how to perform a final check of the installation before power is applied to the drive.



**ATTENTION:** Only qualified electrical personnel familiar with the construction and operation of this equipment and the hazards involved should start and adjust it. Read and understand this manual in its entirety before proceeding. Failure to observe this precaution could result in severe bodily injury or loss of life.

### 9.1 Checking the Installation

Use the following procedure to verify the condition of the installation:



**ATTENTION:** DC bus capacitors retain hazardous voltages after input power has been disconnected. After disconnecting input power, wait five (5) minutes for the DC bus capacitors to discharge and then check the voltage with a voltmeter to ensure the DC bus capacitors are discharged before touching any internal components. Failure to observe this precaution could result in severe bodily injury or loss of life.

- Step 1. Turn off, lock out, and tag the input power to the drive. Wait five minutes.
- Step 2. Verify that the DC bus voltage is zero. Refer to section 10.3.
- Step 3. If a function loss coast-stop pushbutton has been installed, verify that it has been wired correctly. Be sure the factory-installed jumper at terminals 16 and 20 has been removed so that the coast-stop pushbutton will work.



**ATTENTION:** The user must provide an external, hardwired emergency stop circuit outside of the drive circuitry. This circuit must disable the system in case of improper operation. Uncontrolled machine operation may result if this procedure is not followed. Failure to observe this precaution could result in bodily injury.

- Step 4. Remove any debris, such as metal shavings, from around the drive.
- Step 5. Check that there is adequate clearance around the drive.
- Step 6. Verify that there is nothing mounted behind the drive.
- Step 7. Verify that the wiring to the terminal strip and the power terminals is correct.
- Step 8. Check that the wire size is within terminal specification and that the wires are tightened properly.
- Step 9. Check that user-supplied branch circuit protection is installed and correctly rated.

- Step 10. Check that the incoming power is rated correctly.
- Step 11. Check the motor installation and length of motor leads.
- Step 12. Disconnect any power correction capacitors connected between the drive and the motor.
- Step 13. Check that the rating of the transformer (if used) matches the drive requirements and is connected properly.
- Step 14. Verify that a properly-sized ground wire is installed and a suitable earth ground is used. Check for and eliminate any grounds between the motor frame and the motor power leads. Verify that all ground leads are unbroken.
- Step 15. Uncouple the motor from any driven machinery to initially start the drive.

## **9.2 Powering Up After Installation Is Complete**

Use the following procedure to verify that the drive is installed correctly and is receiving the proper line voltage:

- Step 1. Turn the drive's input power disconnect to the On position.
- Step 2. Apply power to the drive.
- Step 3. Follow the start-up procedure in the GV3000/SE Bookshelf Drive Software Start-Up and Reference manual.

## Troubleshooting the Drive

This chapter describes how to troubleshoot the drive and the equipment that is needed to do so. Also provided are replacement part lists and information on clearing faults.

### 10.1 Test Equipment Needed To Troubleshoot

An isolated multimeter will be needed to measure DC bus voltage and to make resistance checks. Note that dedicated troubleshooting test points are not provided.

### 10.2 Drive Alarms and Faults

The drive will display alarm and fault codes to assist in troubleshooting when a problem develops during self-tuning or drive operation.

If an alarm condition occurs, the drive will continue to run and a 2- or 3-digit alarm code will flash on the display.

If a fault occurs, the drive will coast-to-rest stop and a 2- or 3-digit fault code will flash on the display.

Refer to the GV3000/SE Bookshelf Drive Software Start-Up and Reference manual for more information on drive alarms and faults.

### 10.3 Verifying That DC Bus Capacitors Are Discharged



**ATTENTION:** DC bus capacitors retain hazardous voltages after input power has been disconnected. After disconnecting input power, wait five (5) minutes for the DC bus capacitors to discharge and then check the voltage with a voltmeter to ensure the DC bus capacitors are discharged before touching any internal components. Failure to observe this precaution could result in severe bodily injury or loss of life.

The drive's DC bus capacitors retain hazardous voltages after input power has been disconnected. Perform the following steps before touching any internal components:

- Step 1. Disconnect, lock out, and tag all incoming power to the drive.
- Step 2. Wait five minutes for the DC bus capacitors to discharge.
- Step 3. 24 to 43 A drives only: Disconnect all wiring from the face of the drive. Then remove the cover and the front panel.

**Important:** The cover is connected to the drive by the keypad/display cable. To disconnect the cover, use the following procedure. Do not remove the keypad/display.

To remove the cover:

- a. Unscrew the attaching screw on the cover.
- b. Lift the cover and carefully take it out of the heatsink as far as the flat ribbon cable, which connects the display with the Regulator board, allows.
- c. Use a screwdriver to slide the cable out of the connector on the Regulator board to completely detach the cover.

Step 4. Use a voltmeter to verify that there is no voltage at the drive's AC input power terminals (R/L1, S/L2, T/L3). Refer to figure 10.1, 10.2, or 10.3 for the location of these terminals.

Step 5. Ensure that the DC bus capacitors are discharged. To check DC bus potential:

- a. Stand on a non-conductive surface and wear insulated gloves.
- b. Use a voltmeter to measure the DC bus potential at the DC bus power terminals ((-)45, (+)47) shown in figure 10.1, 10.2, or 10.3.

Step 6. 24 to 43 A drives only: Reattach the drive's cover and front panel. Reconnect all wiring to the face of the drive.

**Important:** When replacing the cover on 24 to 43 A drives, check that the display cable is reconnected to the Regulator board. You will need to fold and route the cable under the heatsink before replacing the cover.

Step 7. Reapply input power.

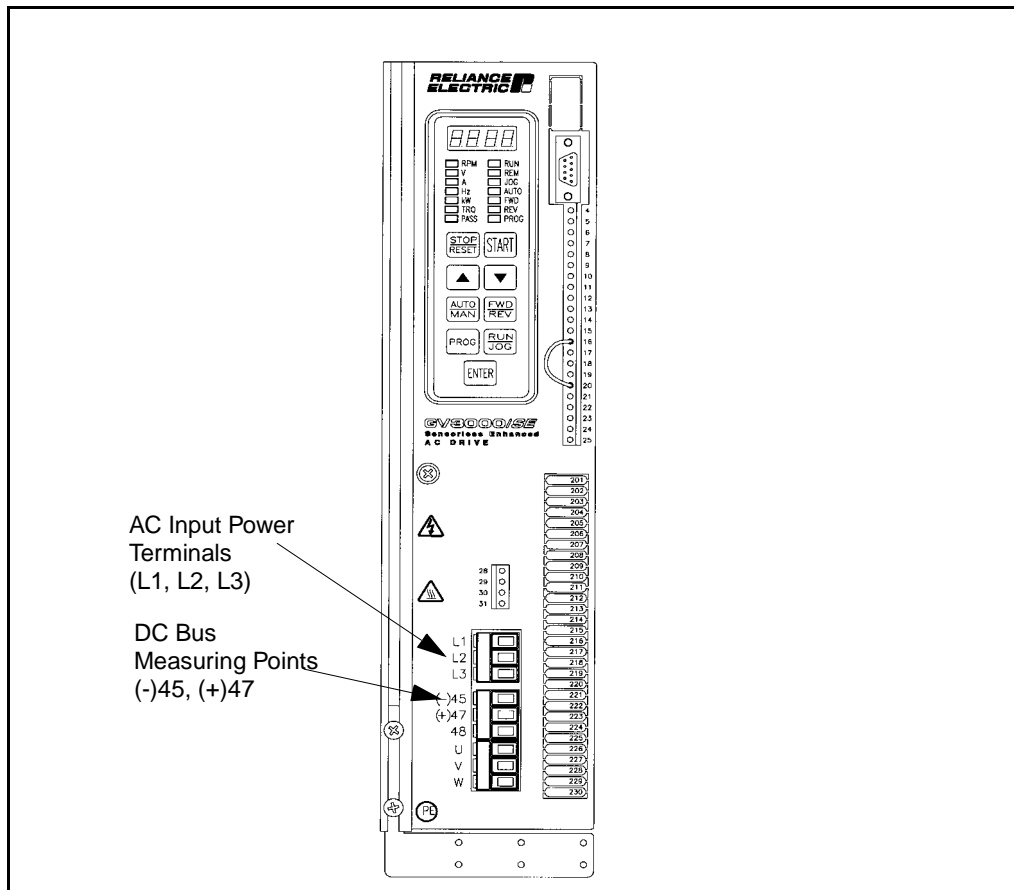

Figure 10.1 – DC Bus Voltage Terminals (2 to 15 Amp Drives)

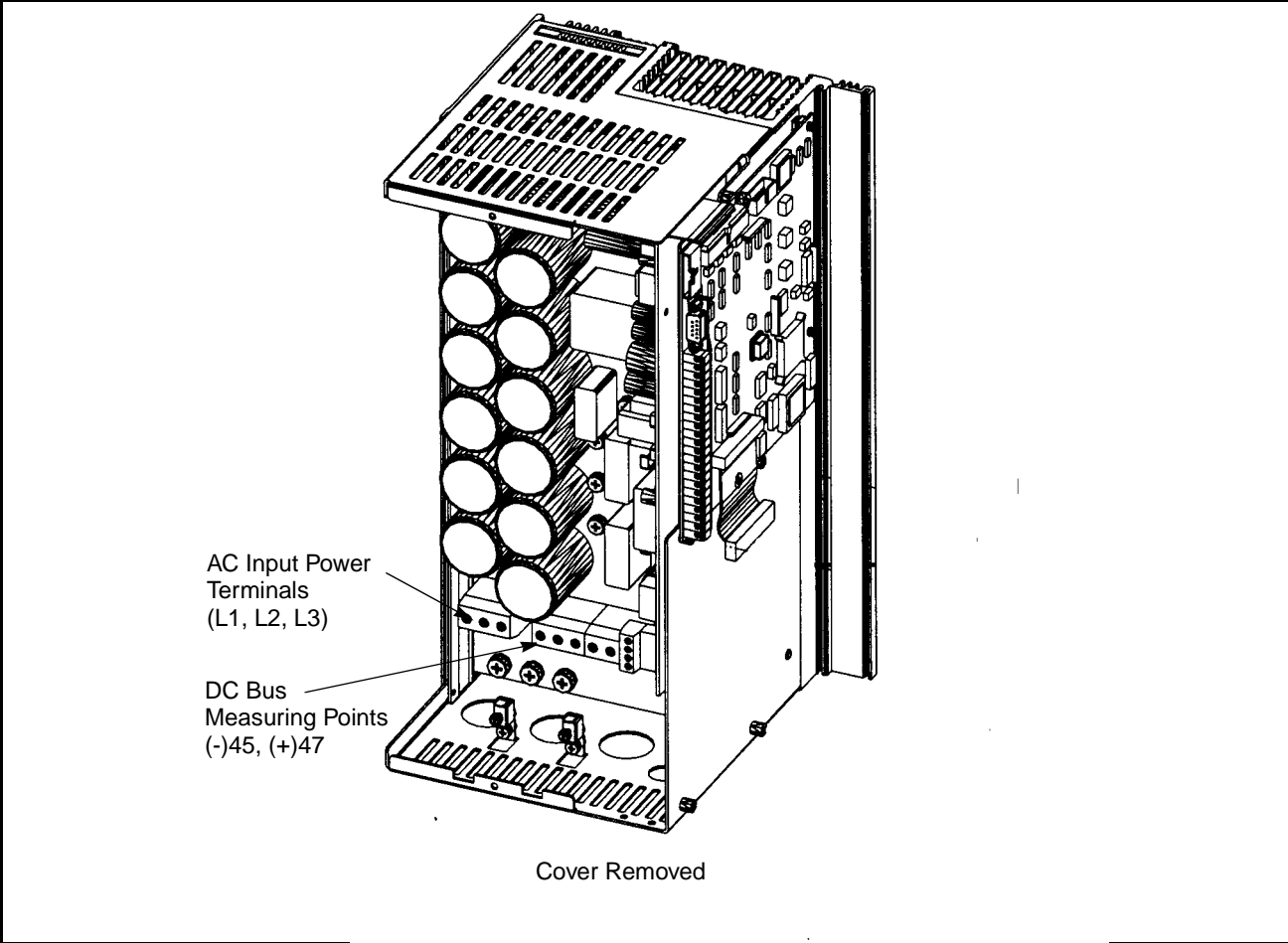

Figure 10.2 – DC Bus Voltage Terminals (24 to 30 Amp Drives)

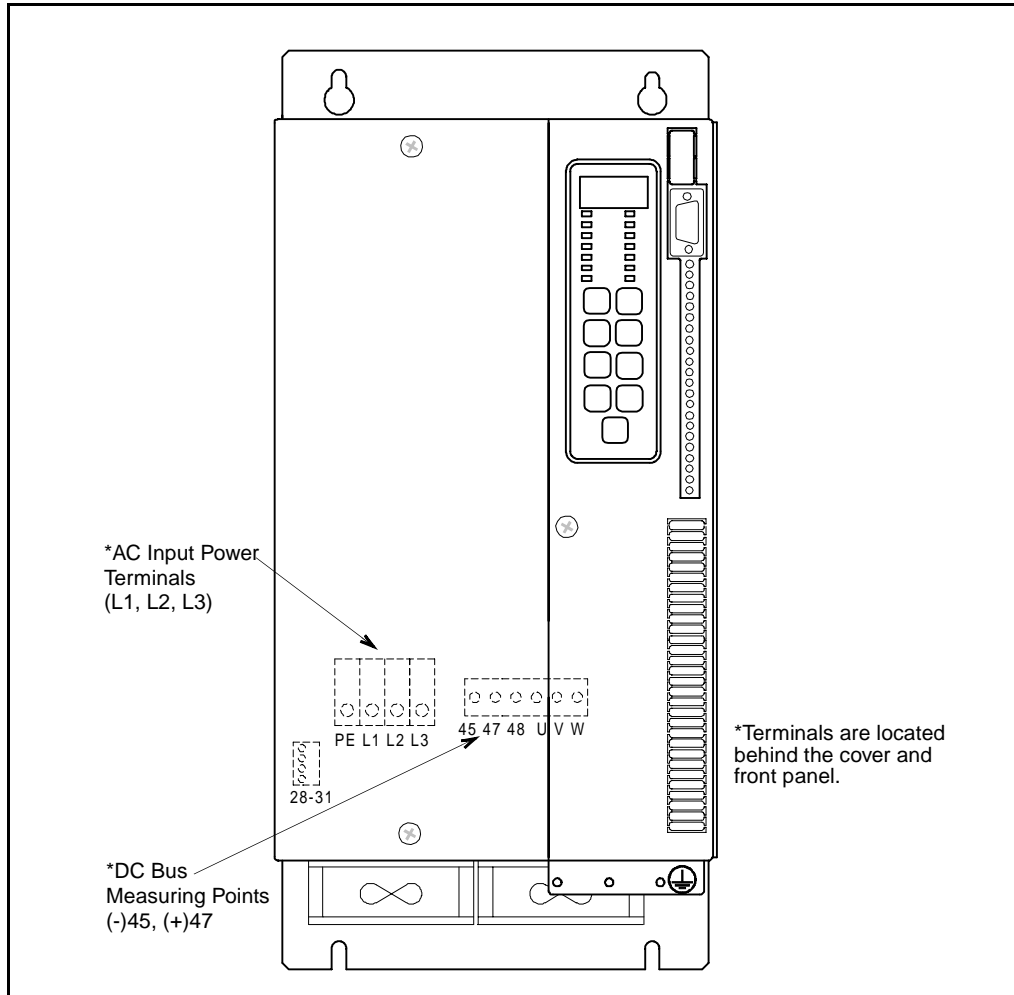

Figure 10.3 – DC Bus Voltage Terminals (43 Amp Drives)

## 10.4 Checking Out the Drive with Input Power Off

Use the following procedure to check the drive circuitry with power off:



**ATTENTION:** DC bus capacitors retain hazardous voltages after input power has been disconnected. After disconnecting input power, wait five (5) minutes for the DC bus capacitors to discharge and then check the voltage with a voltmeter to ensure the DC bus capacitors are discharged before touching any internal components. Failure to observe this precaution could result in severe bodily injury or loss of life.

- Step 1. Disconnect, lock out, and tag all incoming power to the drive.
- Step 2. Wait five minutes for the DC bus capacitors to discharge.
- Step 3. 24 to 43 A drives only: Remove all wiring from the face of the drive. Then remove the drive's cover and front panel.

**Important:** The cover is connected to the drive by the keypad/display cable. To disconnect the cover, use the following procedure. Do not remove the keypad/display.

To remove the cover:

- a. Unscrew the attaching screw on the cover.
- b. Lift the cover and carefully take it out of the heatsink as far as the flat ribbon cable, which connects the display with the Regulator board, allows.
- c. Use a screwdriver to slide the cable out of the connector on the Regulator board to completely detach the cover.

Step 4. Use a voltmeter to verify that there is no voltage at the drive's input power terminals.

Step 5. Check the DC bus potential with a voltmeter as described in section 9.3 to ensure that the DC bus capacitors are discharged.

Step 6. Disconnect the motor from the drive.

Step 7. Check all AC line fuses.

Step 8. If a fuse is open, use a multimeter to check the input diodes and output IGBTs. See table 10.1.

Note that Bookshelf drives do not have replaceable transistor modules. The entire drive must be replaced if a transistor malfunctions.

Step 9. Reconnect the motor to the drive.

Step 10. 24 to 43 A drives only: Reattach the drive's cover and front panel. Reconnect all wiring to the face of the drive.

Step 11. Reapply input power.

Table 10.1 – Resistance Checks

Input Diode No.	Meter Connection		Component is OK if resistance (R) is:	Component is defective if:
	(+)	(-)		
1	47*	1L1(R)	0.3 < R < 8K ohm	Continuity (short circuit) or open when the meter is connected with reversed polarity
2	47*	1L2(S)		
3	47*	1L3(T)		
4	1L1(R)	45*		
5	1L2(S)	45*		
6	1L3(T)	45*		
*If the optional terminals 45 and 47 are not fitted (e.g., on drives with built-in chopper option), remove cover and connect the meter to the measuring points according to the procedure in section 10.3.				

IGBT No.	Meter Connection		Component is OK if resistance (R) is:	Component is defective if:
	(+)	(-)		
V6	47*	W(T3)	0.3 < R < 8K ohm	Continuity (short circuit) or open when the meter is connected with reversed polarity
V5	47*	V(T2)		
V4	47*	U(T1)		
V3	W(T3)	45*		
V2	V(T2)	45*		
V1	U(T1)	45*		
*If the optional terminals 45 and 47 are not fitted (e.g., on drives with built-in chopper option), remove cover and connect the meter to the measuring points according to the procedure in section 10.3.				

## 10.5 Checking the Cooling Fans

On a regular basis, visually check the cooling fans on the base of the unit. If a fan is binding, clogged with dust, or is not functioning, it must be replaced. The replacement part number for the fan is shown in table 10.2.

## 10.6 Replacement Parts

Table 10.2 lists the replacement parts that are available from Reliance Electric. See figures 2.3, 2.4, and 2.5 for the location of the parts.

Table 10.2 – Replacement Parts

Description	Part Number	Quantity per Drive					
		31ER40xx 31ET40xx 38ER40xx 38ET40xx	55ER40xx 55ET40xx 85ER40xx 85ET40xx	126ER40xx 126ET40xx 150ER40xx 150ET40xx	240ER40xx 240ET40xx	300ER40xx 300ET40xx	430ER40xx 430ET40xx
Regulator PCB	814.61.00 <sup>1</sup>	1	1	1	1	1	1
Keypad/Display PCB	814.63.00	1	1	1	1	1	1
Fan	922.67.05	1 <sup>2</sup>	1	2	2	-	-
	922.68.05	-	-	-	-	2	2
Cover	957.85.00	1	1	1	-	-	-
	957.85.10	-	-	-	1	1	1

<sup>1</sup> Specify firmware version 790.46.00A when ordering the Regulator PCB.

<sup>2</sup> On M/N 38ET40xx only (with AC Mains Filter)



## Technical Specifications

Table A.1 – Service Conditions

<p>AC Line Distribution System Capacity (Maximum) for 460 VAC Units</p> <ul style="list-style-type: none"> <li>• Units Not Equipped with an AC Mains Filter</li> <li>• Units Equipped with an AC Mains Filter</li> </ul>	<ul style="list-style-type: none"> <li>• 315 KVA, three-phase with 10,000 amps symmetrical fault current capacity with a line impedance of less than 5%.</li> <li>• 1000 KVA, three-phase with 30,000 amps symmetrical fault current capacity with a line impedance of less than 5%.</li> </ul>
Control Method	All-digital vector, sinusoidal pulse-width-modulated (PWM)
Displacement Power Factor	0.96
Line Frequency	50/60Hz (+2 Hz)
Line Voltage Variation	-10% to +10%
Line Dip Ride-Through	FVC: Maximum 500 milliseconds V/Hz, SVC: Adjustable up to 999.9 seconds (See P.042)
Motor Lead Lengths	76 meters (250 feet) typical (refer to section 3.2.2.4)
Remote Operator Control Wire Length	Up to 303 meters (1000 feet) from the drive
Analog Speed Reference Resolution	1/1024 (10 bits) 0.1%
Acceleration Adjustment Range	0.1 to 999.9 seconds (within the ability of current)
Carrier Frequency	2 kHz, 4 kHz, or 8 kHz, software-selectable
Current Limit Adjustment	Vector: U.006 to 150% (based on motor nameplate rating) V/Hz: 50% to 110% (based on drive nameplate rating)
Service Factor	1.0
Speed Adjustable Range	From 0 RPM to maximum speed (vector)
Speed Regulation	Vector: 0.01% FVC, 0.5% SVC (steady state) V/Hz: Motor slip dependent
Speed Reference Resolution	1 RPM with local keypad, -4095 to +4095 counts with a network or serial reference
Torque Control Response	180 to 220 Hz
Torque Linearity	+3% with optimal parameter setting (typical) (see parameter U.005)

Table A.2 – Environmental Condition

Condition	Specification
Operating Temperature (Ambient)	0° to +40°C (32° to 104°F) coolant air inlet temperature at heatsink Derating factor at 45°C ambient: 7.5% Derating factor at 50°C ambient: 15%
Storage Temperature (Ambient)	-25°C to +55°C
Transportation Temperature (Ambient)	-25°C to +70°C (+70°C during a maximum 24 hours)

Table A.3 – Terminal Strip Input Specifications

Signal Type	Terminal(s)	Specification
Speed Reference Input	12-15	10 V (@ 50K ohm input impedance or 20 mA)
Digital Inputs (1 - 8)	16	+24 VDC Isolated Supply
	17	Remote/Local (Default)
	18	Ramp 1/Ramp 2 (Default)
	19	Forward/Reverse (Default)
	20	Function Loss
	21	Run/Jog
	22	Reset
	23	Stop
	24	Start

Table A.4 – Terminal Strip Output Specifications

Signal Type	Terminal(s)	Specification
Analog Output	10 -11 scaled signal	0-10 VDC (maximum 4 mA, 2.5K ohm impedance) or 4-20 mA

Table A.5 – Flux Vector Regulation Specifications

Specification	Rating
Motor Poles	2, 4, 6, or 8 poles
Overcurrent IET	200% load (based on drive nameplate rating)
Overload Current Rating	150% for 1 minute (based on drive nameplate rating)
Speed Control Range	1:600 with 1024 PPR
Speed Control Response	15 Hz (typical)
Encoder Feedback	15 V differential quadrature, encoder incremental (512 PPR, 1024 PPR, 2048 PPR, 4096 PPR)
Service Factor	1.0

Table A.6 – Input Signal Response Times (Maximum)

Signal Type and Source	Volts/Hertz Regulation*	Vector Regulation*
Keypad START	150 milliseconds	130 milliseconds
Terminal Strip:		
START	126 milliseconds	105 milliseconds
STOP, RESET, FL	75 milliseconds	75 milliseconds
Preset Speeds	75 milliseconds	75 milliseconds
Analog Speed/Trim Reference	16 milliseconds	5 milliseconds
Analog Torque Reference	N/A	0.5 milliseconds
Network:		
START	46 milliseconds + network transport time	25 milliseconds + network transport time
STOP, RESET, FL	26 milliseconds + network transport time	25 milliseconds + network transport time
Analog Speed/Trim Reference	5 milliseconds + network transport time	5 milliseconds + network transport time
Torque Reference	N/A	0.5 milliseconds + network transport time

\*These are the maximum times from transitioning the input to the drive reacting to the input.



## Compliance with Machinery Safety Standard EN 60204-1:1992

The GV3000/SE Bookshelf drive complies with the following sections of machinery safety standard EN 60204-1:1992.

EN60204-1 Section	Title
6 6.2.1 6.2.3 6.3.1 6.4	Protection against electrical shock - Protection by enclosure - Protection against residual voltages - Protection by automatic disconnect of supply - Protection by the use of PELV (Protective Extra Low Voltage)
7 7.2 7.2.3 7.2.6 7.5	Protection of equipment - Overcurrent protection - Control circuits - Transformers - Protection against supply interruption or voltage reduction and subsequent restoration
8 8.2.1 8.2.2 8.2.3 8.2.7 8.3 8.4 8.5 8.6	Equipotential bonding - General (the PE terminal) - Protective conductors (connection points) - Continuity of the protective bonding circuit - Protective conductor connecting points - Bonding to the protective bonding circuit for operational purposes - Insulation failures - Bonding to a common reference potential - Electrical interferences
9 9.1.1 9.1.3 9.1.4 9.2 9.2.1 9.2.2 9.2.3 9.2.5 9.2.5.3 9.2.5.6	Control circuit and control functions - Control circuit supply - Protection - Connection of control devices - Control functions - Start function - Stop function - Operating modes - Operation - Stop - Hold-to-run controls

EN60204-1 Section	Title
9.2.6 9.3 9.3.5 9.4 9.4.2.1 9.4.3 9.4.3.1 9.4.3.2	- Combined start and stop controls - Protective interlocks - Reverse current braking - Control functions in case of failure - Use of proven circuit techniques and components - Provisions for redundancy - Earth faults - Voltage interruption
10 10.2.1 10.8	Operator interface and machine mounted control devices - Pushbutton colors - Displays
11 11.2 11.2.1 11.2.2 11.3 11.3.1 11.5	Control interfaces - Digital input/output interfaces - Inputs - Outputs - Drive interfaces with analog inputs - Separation between control and electric drives - Communications
12 12.2.2 12.2.3 12.3 12.3.1 12.3.2 12.3.3 12.3.4 12.3.5	Electronic equipment - Electronic control equipment - Equipotential bonding - Programmable equipment - Programmable controllers - Memory retention and protection - Programming equipment - Software verification - Use in safety-related functions
13 13.2.3 13.4	Controlgear: Location, mounting and enclosures - Heating effects - Enclosures, doors and openings
15 15.1.1 15.1.3 15.2.2	Wiring practices - General requirements - Conductors of different circuits - Identification of the protective conductor
18 18.2 18.4	Warning signs and item identification - Warning signs - Marking of control equipment
19 19.1	Technical documentation - General

Copies of this standard can be purchased from the American National Standards Institute at [www.ansi.org](http://www.ansi.org).

## Compliance with Electromagnetic Compatibility Standards

### C.1 Introduction

This appendix provides information on the GV3000/SE Bookshelf drive's compliance with European community electromagnetic compatibility standards and covers the following:

- requirements for standards compliance
- instructions on how the drive must be wired.

The GV3000/SE drives listed on the Declaration of Conformity (DOC) have been tested and are in compliance with the following standards:

- EN50081-2 (1993)  
Electromagnetic compatibility - Generic emission standard  
Part 2: Industrial
- EN50082-2 (1995)  
Electromagnetic compatibility - Generic immunity standard  
Part 2: Industrial

Note that the conformity of the GV3000/SE Bookshelf drive to the above standards does not guarantee that the entire installation will be in conformance.

Copies of the Declaration of Conformity (DOC) may be obtained by contacting the Rockwell AutoFax service at 440-646-7777.

### C.2 Compliance Requirements

In order for the GV3000/SE Bookshelf drive to conform to the standards listed in section C.1, the drive must:

- be specified by model number on the DOC.
- have a CE mark. This mark is found on the drive's certification label.
- include an AC Mains Filter.
- be installed according to the instructions in this appendix.

## C.3 Wiring Practices

This section describes how the GV3000/SE drive must be wired to conform to the standards listed in section C.1. Figure C.1 shows a typical wiring configuration for a GV3000/SE Bookshelf drive if an AC Mains Filter is used.

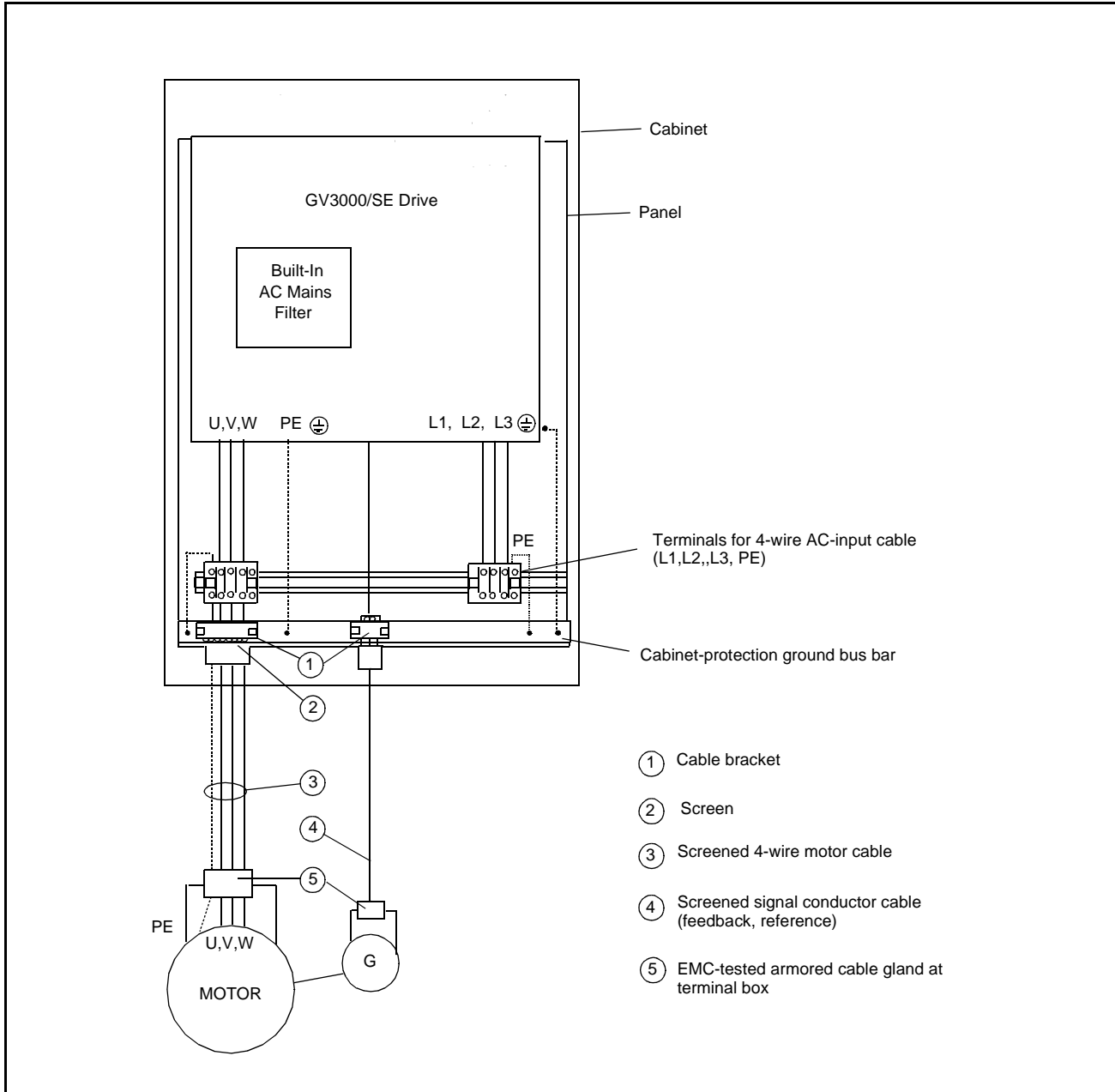

Figure C.1 – Cabinet Mounted GV3000/SE Wiring Example

### C.3.1 Motor Leads

The motor leads must be run in continuous, rigid, conductive conduit, continuously-screened armored cable, or equivalent. Note that the use of flexible metal conduit, open wire, or wire in trays is not acceptable. Many flexible metal conduit products have not been designed for RF containment and are not adequate to maintain compliance.

All motor leads should have the same cross-sectional area. The maximum allowable motor lead length from the drive to the motor is 250' (76m).

A ground (earth) lead, equivalent in size to the motor leads, must be run with the motor leads from the motor to the drive. Terminate this lead in the drive at the ground terminal.

Proper glands must be used to terminate the motor conduit/cable. The gland must secure the cable screen to the conductive surfaces of the drive and motor. A full 360° screen termination is preferred.

Follow all instructions supplied with the motor.

### C.3.2 Grounding the Drive

Connect the drive/filter assembly to earth ground at the terminal provided (see figures 4.1 and 4.2). The ground wire should be sized per EN-60204-1, Part 5.2<sup>1</sup>, for copper conductors and EN-60204-1, Part 8.2.2.2<sup>2</sup>, for non-copper conductors. European Union standards require that the ground wire must be green/yellow according to EN-60204-1, Part 15.2.2.<sup>3</sup>

<sup>1</sup> EN-60204-1, Part 5.2: Minimum Cross-Sectional Area of the External Protective Copper Conductor

<b>Cross-Sectional Area of Phase Conductors Supplying the Equipment (S) (mm<sup>2</sup>)</b>	<b>Minimum Cross-Sectional Area of the External Protective Conductor (mm<sup>2</sup>)</b>
$S \leq 16$	S
$16 < S \leq 35$	16
$S \geq 35$	S/2

<sup>2</sup> EN-60204-1, Part 8.2.2.2: Protective Conductors

Copper conductor should be used. If a material other than copper is used, its electrical resistance per unit length should not exceed that of copper. Non-copper conductors should not be less than 16 mm<sup>2</sup> in cross-sectional area.

<sup>3</sup> EN-60204-1, Part 15.2.2: Identification of the Protective Conductor

For insulated conductors, the two-color combination of Green and Yellow should meet the following criteria for any given 15 mm length: one of the colors should cover at least 30% and no more than 70% of the surface, with the other color covering the remainder of the surface.

### C.3.3 I/O Signals

Control (I/O) and signal wiring must be run in continuous, rigid, conductive conduit or continuously-screened cable as shown in figure C.2. Note that the use of flexible metal conduit, open wire, or wire in trays is not acceptable. Many flexible metal conduit products have not been designed for RF containment and are not adequate to maintain compliance.

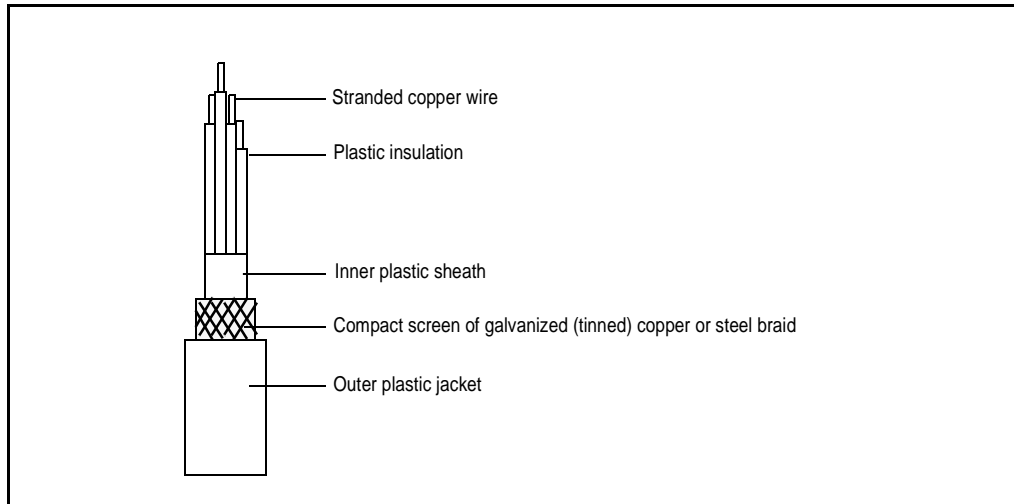

Figure C.2 – I/O Signal Cable

### C.3.4 Operator Control Stations

The enclosure of an operator's control station must be constructed of a conductive metal. The cover of the enclosure should be bonded to the case and not rely on the hinge for bonding. Standard industrial operator devices, e.g., pushbuttons, switches, and meters, may be used.

The wiring connecting the operator's devices to the drive must be run in continuous, rigid, conductive conduit, continuously-screened armored cable, or equivalent. Note that the use of flexible metal conduit, open wire, or wire in trays is not acceptable. Many flexible metal conduit products have not been designed for RF containment and are not adequate to maintain compliance.

Proper glands must be used to terminate the operator's control station conduit/cable at the station and the drive. The gland must secure the cable screen to the conductive surfaces of the drive and station enclosure. A full 360° screen termination is preferred. Screen pigtailed are not permitted.

### C.3.5 Connecting to the AutoMax Network

GV3000/SE drive connections to an AutoMax network require the use of coaxial cable as described in instruction manuals J2-3001 and D2-3308. The coaxial cable must be run in continuous, rigid, conductive conduit.

Proper glands must be used to terminate the conduit at the AutoMax enclosure and the GV3000/SE drive. The gland must secure the cable screen to the conductive surfaces of the drive and AutoMax enclosure. A full 360° screen termination is preferred. Screen pigtailed are not permitted.

### C.3.6 Encoder Cabling

Use only the Reliance Electric encoder cables listed in table C.1.

Table C.1 – Encoder Cabling

<b>Cable Type</b>	<b>Cable Length</b>	<b>Cable Model Number</b>
MS connector on encoder end	25'	2TC4025
MS connector on encoder end	75'	2TC4075
Bare wire on both ends	100'	2TC4100
Bare wire on both ends	300'	2TC4300



## A

- AC input
  - diodes, checking, 10-4 to 10-6
  - disconnect, installing, 5-2
  - isolation, transformer, 5-1 to 5-2
  - line branch circuit fuses, 3-8 to 3-9, 5-2
  - ratings, 2-2
  - wire sizes, 3-5 to 3-6
  - wiring, 3-5 to 3-6, 4-1 to 4-5, 5-1 to 5-3
  - voltage transients, avoiding, 5-1
- AC Mains Filter, 2-12, 5-1, C-1, C-2
- AC output
  - wiring, 3-5 to 3-6, 4-1 to 4-5, 6-1 to 6-2
- Air flow, 3-1, 3-4
- Alarms, 10-1
- Altitude requirements, 3-2
- Ambient conditions 3-2, A-2
- Analog input
  - jumper location, 2-6
  - jumper settings, 2-7 to 2-8
  - specifications, A-2
  - terminal strip connection, 2-10, 7-2
  - wiring, 3-5, 7-8
- Analog output
  - jumper location, 2-6
  - jumper settings, 2-8 to 2-9
  - specifications, A-2
  - terminal strip connection, 2-10, 7-1
  - wiring, 3-6, 7-7
- Assistance, technical, 1-1
- AutoMax Network Option board, 2-11, 2-12

## B

- Board
  - Keypad/Display, 10-7
  - Option, 2-11, 2-12 to 2-13
  - Power, 2-3, 2-4, 2-5, 2-6
  - Regulator, 2-3, 2-4, 2-5, 2-6 to 2-11, 10-7
- Braking resistor
  - selecting, 8-3
  - wiring user-supplied, 8-1 to 8-2, 8-4
- Braking transistor, internal, 2-12

## C

- Capacitors, DC bus, 10-1 to 10-4
- Carrier frequency, 2-2, A-1
- Closed loop control, *see* Vector Regulation
- Communication, network, 2-11
- Communication port (X8), *see* RS-232
- Conduit size
  - 24 to 30 amp drives, 4-4
  - 43 amp drives, 4-5
- Contactors, installing output, 6-1
- Contacts, Form A/B, 2-10, 7-14
- Control and Configuration Software, 1-1, 2-10, 2-13, 3-8
- Control source, 7-1, 7-9
- Control wiring, 2-10, 7-1 to 7-13
- Cover
  - part number, 10-7
  - removing, 10-1 to 10-2
- CS3000, *see* Control and Configuration Software

## D

- DC bus
  - input wiring, 3-5 to 3-6, 4-3, 4-4, 4-5
  - terminals, 10-2 to 10-4
  - verifying capacitor voltage, 10-1 to 10-4
- Declaration of Conformity, C-1
- DeviceNet Network Option board, 2-11, 2-13
- Digital input wiring, 2-10, 7-2, 7-9 to 7-13
- Digital output wiring, *see* Status Relays
- Dimensions,
  - 2 to 30 amp drives, 3-3
  - 43 amp drives, 3-4
- Disconnect, installing input, 5-2
- Display, *see* Keypad/Display
- Distribution system capacity, AC line, 5-1, A-1
- Drive,
  - checking, 10-3 to 10-6
  - component locations, 2-3 to 2-5
  - identifying, 2-1 to 2-2
  - kits, 2-12 to 2-13
  - software, 1-1
  - verifying output current rating, 3-5

## E

- Electromagnetic compatibility standards, drive compliance with, C-1 to C-5
- Emergency stop, 7-4
- EN-60204-1 compliance, 7-4 to 7-5, B-1 to B-2
- Enclosure, 2-2
- Encoder wiring, 3-9, 7-5 to 7-6
- Environmental conditions, 3-2, A-2
- European stock number, 2-1 to 2-2

## F

- Fan
  - checking, 10-7
  - location, 2-3 to 2-5
  - part number, 10-7
- Faults, 10-1
- Flux vector control, 2-1
- Flux vector regulator specifications, A-3
- Form A/B contacts, *see* Status Relays
- Forward (digital input 6), 2-10, 7-2, 7-11
- Frequency, line, A-1
- Function loss (digital input 5), 2-10, 7-2, 7-12
- Fuse
  - AC input, 3-8 to 3-9, 5-2 to 5-3
- FVC, *see* Flux Vector Control

## G

- Grounding, 4-2 to 4-5, 5-3

## H

- Humidity, 3-2, A-2

## I

- IGBT power devices, 2-6
  - testing, resistance checks, 10-5 to 10-6
- Input, AC, *see* AC Input
- Input, digital, *see* Digital Input Wiring
- Input signal response times, A-3
- Input specifications, terminal strip, A-2
- Installation
  - AC input disconnect, 5-2
  - checking, 9-1 to 9-2
  - completing, 9-1 to 9-2
  - fuses, AC input line branch circuit, 3-8 to 3-9, 5-2
  - input isolation transformer, 5-1 to 5-2
  - mechanical motor overload protection, 6-1

- output contactors, 6-1
- planning, 3-1 to 3-9
- requirements, 3-1 to 3-5
- transformers and reactors, 5-1 to 5-2

- IP20 enclosure, 2-2

## J

- Jog (digital input 4), 2-10, 7-2, 7-12
- Jumpers
  - J4, 2-6, 2-7 to 2-8
  - J17, 2-6, 2-8 to 2-9
  - location of 2-6
  - settings for, 2-8, 2-9

## K

- Keypad/display, 2-3, 2-4, 2-5, 2-11, 10-7
- Kits, 2-12 to 2-13

## L

- Lead lengths, motor, 3-6 to 3-7
- LEDs, 2-11
- Line branch circuit fuses, AC input, 3-8 to 3-9, 5-2
- Line frequency, A-1
- Line noise, avoiding, 5-1
- Local (digital input 8), 2-10, 7-2, 7-9

## M

- Machinery Safety Standard EN 60204-1:1992, compliance with, 7-4 to 7-5, B-1 to B-2
- Mains filter, 2-12, 5-1, C-1, C-2
- Mechanical motor overload protection, 6-1
- Meter output, 2-12, 7-1, 7-7
- Model number, 2-1
- MOP (motor operated potentiometer), 7-9 to 7-11
- Motor
  - Encoder Cable kit, 2-12
  - lead lengths, 3-6 to 3-7
  - overload protection, mechanical, 6-1
  - speed, setting maximum, 7-5
  - wiring, 6-1 to 6-2
- Mounting dimensions
  - 2 to 30 amp drives, 3-3
  - 43 amp drives, 3-4

## N

### Network

- AutoMax Network Option board, 2-11, 2-12 communication, 2-11
- ControlNet Network Option board, 2-12
- DeviceNet Network Option board, 2-11, 2-13
- Profibus Network Option board, 2-13

## O

- Open loop control, *see* Volts/Hertz Regulation
- Operator Interface Module, 2-13
- Operator Interface Module connector, 2-11
- Option kits, *see* Kits
- Option board connector, 2-6, 2-11
- Output
  - analog, *see* analog Output
  - contactors, 6-1
  - digital, *see* Status Relays
  - specifications, terminal strip, A-2
- Output relay terminal strip, 2-3, 2-4, 2-5, 2-12, 3-6, 7-2, 7-14
- Overload, motor, 6-1

## P

### Parts

- location, *see* Component Locations
- replacement, 10-7
- PC control, *see* Control Source
- Power board, 2-3, 2-4, 2-5, 2-6
- Power ratings, 2-2
- Power terminals
  - torque specifications, 5-2
  - wiring, 3-5 to 3-6, 4-2 to 4-5, 5-1 to 5-3, 6-1 to 6-2
- Profibus Network Option board, 2-13
- Protection, mechanical motor overload, 6-1
- Publications, related, 1-1

## R

- Ramp 1/Ramp 2 (digital input 7), 2-10, 7-2, 7-10
- Rating
  - AC input, 2-2
  - enclosure, 2-2
  - fuse, 3-8 to 3-9
  - output, 2-2
  - power loss, 2-2
- Regulator board, 2-3, 2-4, 2-5, 2-6 to 2-11, 7-1 to 7-3, 7-7 to 7-13, 10-7
- Relays, output status, *see* Status Relays

- Reliance, getting assistance from, 1-1
- Remote (digital input 8), 2-10, 7-2, 7-9
- Remote Meter Interface board, 2-13
- Removing cover, 10-1 to 10-2
- Replacement parts, 10-5
- Reset (digital input 3), 2-10, 7-2, 7-13
- Reverse (digital input 6), 2-10, 7-2, 7-11
- RS-232
  - cable length, 3-8
  - communication port (X8), 2-6, 2-10, 3-8
- Run (digital input 4), 2-10, 7-2, 7-12

## S

- Selecting operation, *see* Control Source
- Sensorless vector control, 2-1
- Serial communication, *see* RS-232
- Site requirements, 3-1 to 3-2
- Software, drive, 1-1
- Space requirements,
  - 2 to 30 amp drives, 3-3
  - 43 amp drives, 3-4
- Specifications, technical, A-1 to A-3
- Speed, maximum setting, 7-5
- Start (digital input 1), 2-10, 7-2, 7-13
- Status relays, Form A/B, 2-12, 7-2, 7-14
- Stop (digital input 2), 2-10, 7-2, 7-13
- Stopping the drive, 7-4 to 7-5
- Super Remote Meter Interface board, 2-13
- SVC, *see* Sensorless Vector Control
- Switch, membrane, *see* Keypad/Display

## T

- Tachometer, pulse, *see* Encoder
- Terminal strip,
  - input specifications, A-2
  - output specifications, A-2
  - output relay, 2-3, 2-4, 2-5, 2-12, 7-2, 7-14
  - Regulator board, 2-6, 2-10, 7-1 to 7-13
  - torque specifications, 3-6
  - wiring, 2-10, 3-6, 7-1 to 7-14
- Testing, IGBT, 10-4 to 10-6
- Transformer, installing isolation input, 5-1
- Transients, AC line voltage, 5-1

## V

- Vector regulation, 2-1
- Ventilation, *see* Air Flow
- Volts/hertz regulation, 2-1

## **W**

Watts loss rating, 2-2, 4-1

Weight,

    2 to 30 amp drives, 3-3

    43 amp drives, 3-4

Wire routing, 4-2 to 4-5

Wire sizes, 3-5, 3-6, 3-8, 3-9

# Documentation Improvement Form

Use this form to give us your comments concerning this publication or to report an error that you have found. For convenience, you may attach copies of the pages with your comments. After you have completed this form, please return it to:

Reliance Electric  
 Technical Documentation  
 24800 Tungsten Road  
 Cleveland, Ohio 44117  
 Fax: 216.266.7785

Publication Name: <b>GV3000/SE AC Bookshelf Drive Hardware Reference, Installation, and Troubleshooting Version 6.06</b>	
Publication Number: <b>D2-3427-2</b>	Publication Date: December <b>2000</b>

Comments: \_\_\_\_\_

\_\_\_\_\_

\_\_\_\_\_

\_\_\_\_\_

\_\_\_\_\_

\_\_\_\_\_

Your Name:	Date:
Company Name:	Phone: (    )
Address:	

Thank you for your comments.

<b>Technical Writing Internal Use</b>	
Date:	DIF Number:
Follow-Up Action:	





---

**Reach us now at [www.rockwellautomation.com](http://www.rockwellautomation.com)**

Wherever you need us, Rockwell Automation brings together leading brands in industrial automation including Allen-Bradley controls, Reliance Electric power transmission products, Dodge mechanical power transmission components, and Rockwell Software. Rockwell Automation's unique, flexible approach to helping customers achieve a competitive advantage is supported by thousands of authorized partners, distributors and system integrators around the world.

**Americas Headquarters**, 1201 South Second Street, Milwaukee, WI 53204, USA, Tel: (1) 414 382 2000, Fax: (1) 414 382 4444  
**European Headquarters SA/IV**, Boulevard du Souverain 36, 1170 Brussels, Belgium, Tel: (32) 2 663 06 00, Fax: (32) 2 663 06 40  
**Asia Pacific Headquarters**, 27/F Citicorp Centre, 18 Whitfield Road, Causeway Bay, Hong Kong, Tel: (852) 2887 4788, Fax: (852) 2508 1846  
**Reliance Electric Standard Drives Business**, 24800 Tungsten Road, Cleveland, OH 44117, USA, Tel: (1) 888 374 8370, Fax: (216) 266 7095

